

Datasheet

SATADOM-SL

3IE4 series

- SATA III solution for industrial field
- Exclusive L³ architecture
- DRAM-less, 100% data integrity
- Excellent random performance
- Designed with hardware LDPC ECC engine
- Built-in Pin 8 power supply



Introduction

Innodisk SATADOM-SL 3IE4 is characterized by L³ architecture with the latest SATA III (6.0GHz) Marvell NAND controller. Innodisk's exclusive L³ architecture is L² architecture multiplied LDPC (Low Density Parity Check). L² (Long Life) architecture is a 4K mapping algorithm that reduces WAF and features a real-time wear leveling algorithm to provide high performance and prolong lifespan with exceptional reliability.

Innodisk SATADOM-SL 3IE4 is designed for industrial field, and supports several standard features, including TRIM, NCQ, and S.M.A.R.T. In addition, Innodisk's exclusive industrial-oriented firmware provides a flexible customization service, making it perfect for a variety of industrial applications.

The innovative Pin 8 uses the SATA connector itself as a power supply to drive the device without external cables. It could be connected directly to the SATA on-board socket on customer's system without additional power cable. Besides, the booting time for operation and the power consumption is less than hard disk drive (HDD), and can work under harsh environment compile with ATA protocol, no additional drives are required, and the SSD can be configured as a boot device or data storage device.

SATADOM-SL

3IE4 series

Diagram

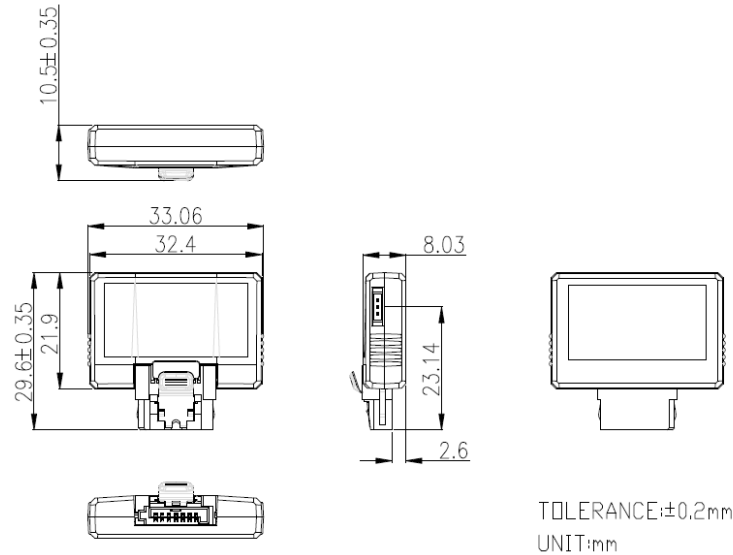

Specifications

Interface	SATA III
Flash Type	iSLC
Capacity	8GB~64GB
Max. Channels	2
Sequential R/W (MB/sec, max.)	530/350
Max. Power Consumption	1.33W (5Vx265.1mA)
Thermal Sensor	√
Extended DRAM buffer	-
H/W Write Protect	-
ATA Security	√
S.M.A.R.T.	√
Dimension (WxLxH)	33.06 x 29.6 x 10.5 mm
Environment	Vibration: 20G @7~2000Hz Shock: 1500G @ 0.5ms Storage Temperature: -55°C ~ +95°C MTBF: 3 million hours

20171208

Ordering Information

	8GB	16GB	32GB(1CH)	32GB(2CH)	64GB
Standard Grade (0°C ~ +70°C)	DHSSL-08GM41BC1SC*	DHSSL-16GM41BC1SC*	DHSSL-32GM41BC1SC*	DHSSL-32GM41BCADC*	DHSSL-64GM41BCADC*
Industrial Grade (-40°C ~ +85°C)	DHSSL-08GM41BW1SC*	DHSSL-16GM41BW1SC*	DHSSL-32GM41BW1SC*	DHSSL-32GM41BWADC*	DHSSL-64GM41BWADC*

*=A-> Pin 8+ power cable
*=B-> Pin 8+ Pin 7

innodisk

Distributore Autorizzato per l'Italia:

Contradata Milano S.r.l.

Via Solferino 12, 20900 Monza (MB) - Italy

Tel: (+39) 039-230.14.92 | Email: info@contradata.it



www.contradata.it