

Datasheet

CFast 3IE7 series

- High IOPS
- iSMART disk health monitoring
- iPower Guard for protecting unstable start up and shut down.
- iData Guard for abnormal power failure
- DEVSLP supported
- Support iSLC technology



Introduction

Innodisk CFast 3IE7 is SATA III 6.0 Gb/s flash based disk, which adopts latest SATA III NAND controller with Innodisk's exclusive L³ FW architecture. The upgraded L³ FW architecture, combining Innodisk signature 4K mapping algorithm L² FW architecture with powerful LDPC technology, makes 3IE7 series have outstanding high IOPS, better data integrity and extended lifespan through reducing the bad block number happening. Built-in thermal sensor, and iData Guard ensure data integrity and reliability of CFast 3IE7 for industrial applications.

innodisk

Distributore Autorizzato per l'Italia:

Contradata Milano S.r.l.

Via Solferino 12, 20900 Monza (MB) - Italy

Tel: (+39) 039-230.14.92 | Email: info@contradata.it

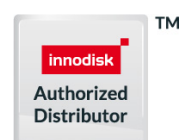

www.contradata.it

CFast 3IE7 series

Contact us for more information about the CFast 3IE7

Innodisk is a service-driven provider of industrial embedded flash and DRAM storage products and technologies, with a focus on the cloud computing, industrial/embedded, and aerospace and defense industries.

Drawing

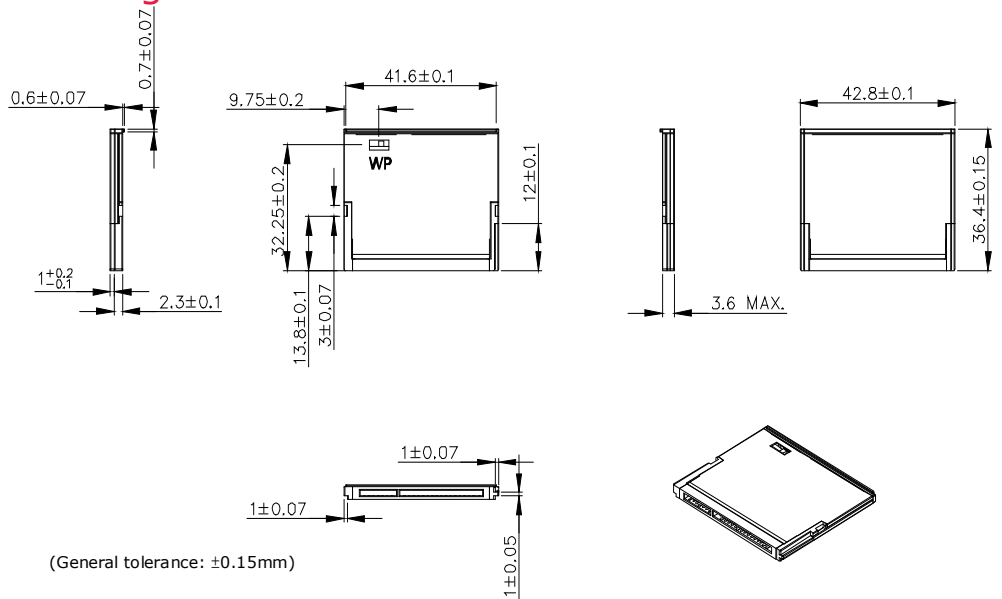

Specifications

Interface	SATA III
Flash Type	iSLC
Capacity	40GB~320GB
Max. Channels	4
Sequential R/W (MB/sec, max.)	550/520
Max. Power Consumption	1.4 W
Thermal Sensor	✓
External DRAM Buffer	-
H/W Write Protect	Optional*
ATA Security	✓
S.M.A.R.T.	✓
Dimension (WxLxH)	42.8X 36.4 X 3.6 mm
Environment	Vibration: 20G @7~2000Hz Shock: 1500G @ 0.5ms Storage Temperature: -40°C ~ +85°C MTBF: 3 million hours

20210504

Ordering Information

Operation Temp.	40GB	80GB	160GB	320GB
Standard Grade (0°C ~ +70°C)	DHCFA-40GDK1GCADL(W)	DHCFA-80GDK1GCAQL(W)	DHCFA-A60DK1GCAQL(W)	DHCFA-D2GDK1GCAQQ(W)
Industrial Grade (-40°C ~+85°C)	DHCFA-40GDK1GWADL(W)	DHCFA-80GDK1GWAQL(W)	DHCFA-A60DK1GWAQL(W)	DHCFA-D2GDK1GWAQQ(W)

*H/W write protect function is optional.
(For the write protect demand, please place the order by PN: DHCFA-xxxDK1GxAxx**W**)
*D: Dual channel / Q: four channel

innodisk

Distributore Autorizzato per l'Italia:

Contradata Milano S.r.l.

Via Solferino 12, 20900 Monza (MB) - Italy

Tel: (+39) 039-230.14.92 | Email: info@contradata.it

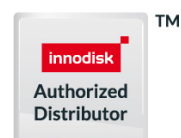

www.contradata.it