

**MODEL:
IMBA-H110**

**ATX Motherboard Supports 6th Generation LGA1151
Intel® Core™ i7/i5/i3, Pentium® or Celeron® CPU,
Intel® H110 Chipset, DDR4, HDMI, DVI-I, iDP, SATA 6Gb/s,
USB 3.0, Dual Intel® GbE LAN, HD Audio and RoHS**

User Manual

Revision

Date	Version	Changes
October 31, 2016	1.00	Initial release

Copyright

COPYRIGHT NOTICE

The information in this document is subject to change without prior notice in order to improve reliability, design and function and does not represent a commitment on the part of the manufacturer.

In no event will the manufacturer be liable for direct, indirect, special, incidental, or consequential damages arising out of the use or inability to use the product or documentation, even if advised of the possibility of such damages.

This document contains proprietary information protected by copyright. All rights are reserved. No part of this manual may be reproduced by any mechanical, electronic, or other means in any form without prior written permission of the manufacturer.

TRADEMARKS

All registered trademarks and product names mentioned herein are used for identification purposes only and may be trademarks and/or registered trademarks of their respective owners.

Manual Conventions



WARNING

Warnings appear where overlooked details may cause damage to the equipment or result in personal injury. Warnings should be taken seriously.



CAUTION

Cautionary messages should be heeded to help reduce the chance of losing data or damaging the product.



NOTE

These messages inform the reader of essential but non-critical information. These messages should be read carefully as any directions or instructions contained therein can help avoid making mistakes.



HOT SURFACE

This symbol indicates a hot surface that should not be touched without taking care.

Table of Contents

1 INTRODUCTION.....	1
1.1 INTRODUCTION.....	2
1.2 FEATURES.....	3
1.3 CONNECTORS	4
1.4 DIMENSIONS.....	5
1.5 DATA FLOW	6
1.6 TECHNICAL SPECIFICATIONS	7
2 PACKING LIST.....	10
2.1 ANTI-STATIC PRECAUTIONS	11
2.2 UNPACKING PRECAUTIONS.....	11
2.3 PACKING LIST.....	12
2.4 OPTIONAL ITEMS	13
3 CONNECTORS	15
3.1 PERIPHERAL INTERFACE CONNECTORS.....	16
3.1.1 <i>IMBA-H110 Layout</i>	16
3.1.2 <i>Peripheral Interface Connectors</i>	17
3.1.3 <i>External Interface Panel Connectors</i>	18
3.2 INTERNAL PERIPHERAL CONNECTORS	19
3.2.1 <i>+12V Power Connector</i>	19
3.2.2 <i>Additional Power Connector</i>	19
3.2.3 <i>ATX Power Connector</i>	20
3.2.4 <i>Battery Connector</i>	22
3.2.5 <i>Chassis Intrusion Connector</i>	23
3.2.6 <i>CRT FW Update Connector</i>	24
3.2.7 <i>DDR4 DIMM Slots</i>	24
3.2.8 <i>Digital I/O Connector</i>	25
3.2.9 <i>EC Debug Connector</i>	26
3.2.10 <i>Fan Connector (CPU)</i>	27

3.2.11 Fan Connectors (System)	28
3.2.12 Front Panel Audio Connector	29
3.2.13 Front Panel Connector	30
3.2.14 PC Connector	31
3.2.15 Internal DisplayPort Connector	32
3.2.16 Keyboard and Mouse Connector	33
3.2.17 LAN LED Connectors	34
3.2.18 Parallel Port Connector	35
3.2.19 PCI Slots	36
3.2.20 PCI Express x16 Slot.....	37
3.2.21 PCIe Mini Slot.....	37
3.2.22 Power Button	39
3.2.23 RS-232 Serial Port Connector	40
3.2.24 RS-232/422/485 Serial Port Connector	41
3.2.25 SATA 6Gb/s Drive Connector	42
3.2.26 SMBus Connector	44
3.2.27 SPI Flash Connector.....	45
3.2.28 SPI Flash Connector, EC	46
3.2.29 TPM Connector.....	47
3.2.30 USB 2.0 Connector (Type A).....	48
3.2.31 USB 2.0 Connector	49
3.3 EXTERNAL PERIPHERAL INTERFACE CONNECTOR PANEL	50
3.3.1 Audio Connector	50
3.3.2 DVI-I and HDMI Connectors	51
3.3.3 Ethernet and USB 3.0 Connectors	53
3.3.4 Keyboard/Mouse and USB 2.0 Connectors	54
3.3.5 Serial Port Connectors	55
4 INSTALLATION	56
4.1 ANTI-STATIC PRECAUTIONS	57
4.2 INSTALLATION CONSIDERATIONS.....	57
4.3 SOCKET LGA1151 CPU INSTALLATION	59
4.4 SOCKET LGA1151 COOLING KIT INSTALLATION	62
4.5 DIMM INSTALLATION	64
4.6 FULL-SIZE PCIe MINI CARD INSTALLATION	65

IMBA-H110 ATX Motherboard

4.7 HALF-SIZE PCIE MINI CARD INSTALLATION.....	66
4.8 SYSTEM CONFIGURATION.....	68
4.8.1 AT/ATX Power Mode Setting.....	68
4.8.2 Clear CMOS Button.....	69
4.8.3 DVI/CRT Selection Switch.....	69
4.8.4 Flash Descriptor Security Override.....	70
4.8.5 mSATA Setup Jumper.....	71
4.8.6 USB Power Selection.....	72
4.9 INTERNAL PERIPHERAL DEVICE CONNECTIONS.....	72
4.9.1 SATA Drive Connection.....	72
4.10 ADDING USB 3.0 DRIVERS TO A WINDOWS 7 INSTALLATION IMAGE.....	74
4.11 DRIVER INSTALLATION.....	76
5 BIOS.....	78
5.1 INTRODUCTION.....	79
5.1.1 Starting Setup.....	79
5.1.2 Using Setup.....	79
5.1.3 Getting Help.....	80
5.1.4 Unable to Reboot after Configuration Changes.....	80
5.1.5 BIOS Menu Bar.....	80
5.2 MAIN.....	81
5.3 ADVANCED.....	82
5.3.1 Trusted Computing.....	83
5.3.2 ACPI Settings.....	84
5.3.3 Super IO Configuration.....	85
5.3.3.1 Serial Port 1 ~ 5 Configuration.....	86
5.3.3.2 Serial Port 1 Configuration.....	86
5.3.3.3 Serial Port 2 Configuration.....	87
5.3.3.4 Serial Port 3 Configuration.....	87
5.3.3.5 Parallel Port Configuration.....	90
5.3.4 iWDD H/W Monitor.....	91
5.3.4.1 Smart Fan Mode Configuration.....	92
5.3.5 RTC Wake Settings.....	93
5.3.6 Serial Port Console Redirection.....	95
5.3.6.1 Legacy Console Redirection Settings.....	97

5.3.7 CPU Configuration	98
5.3.8 SATA Configuration.....	100
5.3.9 NVMe Configuration.....	101
5.3.10 USB Configuration.....	102
5.3.11 iEi Feature.....	103
5.4 CHIPSET	104
5.4.1 System Agent (SA) Configuration	105
5.4.1.1 Graphics Configuration.....	106
5.4.1.2 PEG Port Configuration.....	108
5.4.1.3 Memory Configuration	109
5.4.2 PCH-IO Configuration	110
5.4.2.1 PCI Express Configuration	112
5.4.2.2 HD Audio Configuration.....	114
5.5 SECURITY.....	115
5.6 BOOT.....	116
5.7 SAVE & EXIT	118
A REGULATORY COMPLIANCE	119
B PRODUCT DISPOSAL	121
C BIOS OPTIONS	123
D TERMINOLOGY	127
E DIGITAL I/O INTERFACE	131
E.1 INTRODUCTION	132
E.2 ASSEMBLY LANGUAGE SAMPLE 1	133
E.3 ASSEMBLY LANGUAGE SAMPLE 2	133
F WATCHDOG TIMER.....	134
G HAZARDOUS MATERIALS DISCLOSURE	137

List of Figures

Figure 1-1: IMBA-H110	2
Figure 1-2: Connectors	4
Figure 1-3: IMBA-H110 Dimensions (mm).....	5
Figure 1-4: Data Flow Diagram.....	6
Figure 3-1: Peripheral Interface Connectors	16
Figure 3-2: +12V Power Connector Pinout Location	19
Figure 3-3: Additional Power Connector Location.....	20
Figure 3-4: ATX Power Connector Location	21
Figure 3-5: Battery Connector Location.....	22
Figure 3-6: Chassis Intrusion Connector Location.....	23
Figure 3-7: CRT FW Update Connector Location.....	24
Figure 3-8: DDR4 DIMM Slot Locations	25
Figure 3-9: Digital I/O Connector Location	25
Figure 3-10: EC Debug Connector Location.....	26
Figure 3-11: CPU Fan Connector Location	27
Figure 3-12: System Fan Connector Locations.....	28
Figure 3-13: Front Panel Audio Connector Location	29
Figure 3-14: Front Panel Connector Location	30
Figure 3-15: I ² C Connector Location	31
Figure 3-16: Internal DisplayPort Connector Location	32
Figure 3-17: Keyboard and Mouse Connector Location.....	33
Figure 3-18: LAN1 LED Connector Location	34
Figure 3-19: Parallel Port Connector Location	35
Figure 3-20: PCI Slot Locations	36
Figure 3-21: PCIe x16 Slot Location	37
Figure 3-22: PCIe Mini Slot Location	38
Figure 3-23: Power Button Location.....	39
Figure 3-24: RS-232 Serial Port Connector Locations.....	40
Figure 3-25: RS-232/422/485 Connector Location.....	41
Figure 3-26: SATA 6Gb/s Drive Connector Location	43

Figure 3-27: SMBus Connector Location	44
Figure 3-28: SPI Flash Connector Location	45
Figure 3-29: SPI EC Flash Connector Location	46
Figure 3-30: TPM Connector Location.....	47
Figure 3-31: USB 2.0 Connector (Type A) Pinout Location.....	48
Figure 3-32: USB 2.0 Connector Pinout Locations	49
Figure 3-33: External Peripheral Interface Connector	50
Figure 3-34: Audio Connector	51
Figure 3-35: DVI-I Connector	52
Figure 3-36: LAN Connector	53
Figure 3-37: Serial Port Connector Pinouts.....	55
Figure 4-1: Disengage the CPU Socket Load Lever.....	59
Figure 4-2: Remove Protective Cover.....	60
Figure 4-3: Insert the Socket LGA1151 CPU.....	61
Figure 4-4: Close the Socket LGA1151	61
Figure 4-5: Cooling Kit Support Bracket.....	63
Figure 4-6: DIMM Installation.....	64
Figure 4-7: Removing the Retention Screw	65
Figure 4-8: Inserting the Full-size PCIe Mini Card into the Slot at an Angle	65
Figure 4-9: Securing the Full-size PCIe Mini Card	66
Figure 4-10: Installing the Standoff	67
Figure 4-11: Inserting the Half-size PCIe Mini Card into the Slot at an Angle.....	67
Figure 4-12: Securing the Half-size PCIe Mini Card	68
Figure 4-13: AT/ATX Power Mode Switch Location	68
Figure 4-14: Clear CMOS Button Location.....	69
Figure 4-15: DVI/CRT Selection Switch Location	70
Figure 4-16: Flash Descriptor Security Override Jumper Location	70
Figure 4-17: mSATA Setup Jumper Location	71
Figure 4-18: SATA Drive Cable Connection.....	73
Figure 4-19: SATA Power Drive Connection.....	74
Figure 4-20: Windows 7 USB 3.0 Creator Utility.....	75
Figure 4-21: Update Process is Complete	76

List of Tables

Table 1-1: IMBA-H110 Specifications	9
Table 2-1: Packing List.....	13
Table 2-2: Optional Items	14
Table 3-1: Peripheral Interface Connectors	18
Table 3-2: Rear Panel Connectors	18
Table 3-3: +12V Power Connector Pinouts	19
Table 3-4: Additional Power Connector Pinouts	20
Table 3-5: ATX Power Connector Pinouts	21
Table 3-6: Chassis Intrusion Connector Pinouts	23
Table 3-7: CRT FW Update Connector Pinouts	24
Table 3-8: Digital I/O Connector Pinouts.....	26
Table 3-9: EC Debug Connector Pinouts	27
Table 3-10: CPU Fan Connector Pinouts	27
Table 3-11: System Fan Connector Pinouts	28
Table 3-12: Front Panel Audio Connector Pinouts	29
Table 3-13: Front Panel Connector Pinouts.....	30
Table 3-14: I ² C Connector Pinouts.....	31
Table 3-15: Internal DisplayPort Connector Pinouts	32
Table 3-16: Keyboard and Mouse Connector Pinouts	33
Table 3-17: LAN LED Connector Pinouts.....	34
Table 3-18: Parallel Port Connector Pinouts	35
Table 3-19: PCIe Mini Slot Pinouts.....	39
Table 3-20: RS-232 Serial Port Connector Pinouts	40
Table 3-21: RS-232/422/485 Connector Pinouts	41
Table 3-22: DB-9 RS-232/422/485 Pinouts	42
Table 3-23: SATA 6Gb/s Drive Connector Pinouts.....	43
Table 3-24: SMBus Connector Pinouts	44
Table 3-25: SPI Flash Connector Pinouts	45
Table 3-26: SPI EC Flash Connector Pinouts	46
Table 3-27: TPM Connector Pinouts	47

Table 3-28: USB 2.0 Connector (Type A) Pinouts	48
Table 3-29: USB 2.0 Connector Pinouts	49
Table 3-30: DVI-I Connector Pinouts	52
Table 3-31: HDMI Connector Pinouts	52
Table 3-32: USB 3.0 Port Pinouts	53
Table 3-33: LAN Pinouts	53
Table 3-34: USB 2.0 Port Pinouts	54
Table 3-35: PS/2 Connector Pinouts	54
Table 3-36: Serial Port Connector Pinouts	55
Table 4-1: AT/ATX Power Mode Switch Settings	69
Table 4-2: DVI/CRT Selection Switch Settings	69
Table 4-3: Flash Descriptor Security Override Jumper Settings	70
Table 4-4: mSATA Setup Jumper Settings	71
Table 4-5: BIOS Options and Configured USB Ports	72
Table 4-6: USB Power Source Setup	72
Table 5-1: BIOS Navigation Keys	80
Table 5-2: BIOS Options and Configured USB Ports	111

BIOS Menus

BIOS Menu 1: Main	81
BIOS Menu 2: Advanced	82
BIOS Menu 3: Trusted Computing	83
BIOS Menu 4: ACPI Configuration	84
BIOS Menu 5: Super IO Configuration.....	85
BIOS Menu 6: Serial Port 1 ~ 5 Configuration Menu.....	86
BIOS Menu 7: Parallel Port Configuration Menu	90
BIOS Menu 8: iWDD H/W Monitor	91
BIOS Menu 9: Smart Fan Mode Configuration	92
BIOS Menu 10: RTC Wake Settings	94
BIOS Menu 11: Serial Port Console Redirection	95
BIOS Menu 12: Legacy Console Redirection Settings	97
BIOS Menu 13: CPU Configuration	98
BIOS Menu 14: SATA Configuration	100
BIOS Menu 15: NVMe Configuration.....	101
BIOS Menu 16: USB Configuration	102
BIOS Menu 17: iEi Feature	103
BIOS Menu 18: Chipset	104
BIOS Menu 19: System Agent (SA) Configuration	105
BIOS Menu 20: Graphics Configuration	106
BIOS Menu 21: PEG Port Configuration.....	108
BIOS Menu 22: Memory Configuration.....	109
BIOS Menu 23: PCH-IO Configuration	110
BIOS Menu 24: PCI Express Configuration	112
BIOS Menu 25: MPCIE1 Slot	112
BIOS Menu 26: HD Audio Configuration	114
BIOS Menu 27: Security	115
BIOS Menu 28: Boot	116
BIOS Menu 29: Save & Exit.....	118

Chapter

1

Introduction

1.1 Introduction

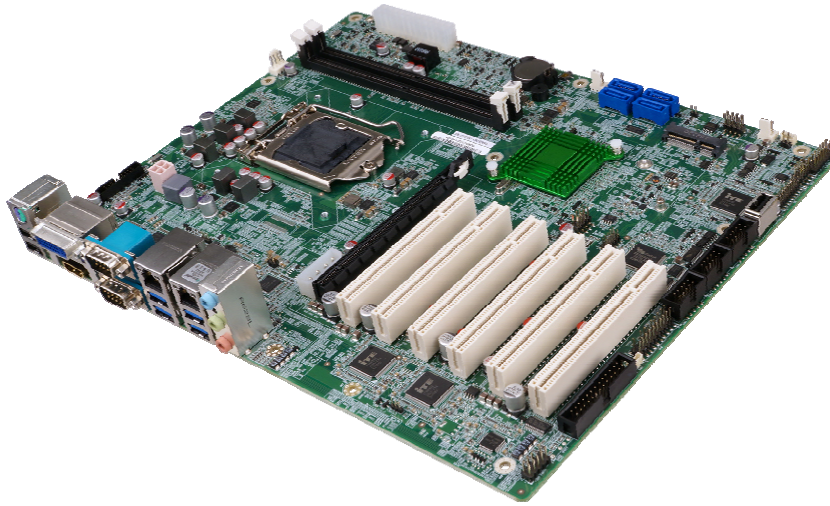

Figure 1-1: IMBA-H110

The IMBA-H110 is an ATX motherboard. It accepts a Socket LGA1151 Intel® Core™ i7/i5/i3, Pentium® or Celeron® processor and supports two 288-pin 2133 MHz dual-channel DDR4 DIMMs up to 64 GB.

The IMBA-H110 provides two GbE interfaces through the Intel® I219LM and the Intel® I211 PCIe controllers. The integrated Intel® H110 chipset supports four SATA 6Gb/s drives. In addition, the IMBA-H110 includes HDMI, DVI-I and iDP interfaces for dual independent display.

Expansion and I/O include six PCI slots, one PCIe x16 slot, one PCIe Mini slot with mSATA support, four USB 3.0 and two USB 2.0 on the rear panel, two USB 2.0 by pin headers, one USB 2.0 by internal Type A connector, four RS-232 and one RS-232/422/485. High Definition Audio (HDA) support ensures HDA devices can be easily implemented on the IMBA-H110.

IMBA-H110 ATX Motherboard

1.2 Features

Some of the IMBA-H110 motherboard features are listed below:

- ATX form factor
- 6th generation LGA1151 Intel® Core™ i7/i5/i3, Pentium® or Celeron® processor supported
- Intel® H110 chipset
- Two 288-pin 2133 MHz dual-channel unbuffered DDR4 DIMMs support up to 64 GB
- Two Intel® PCIe GbE connectors
- Dual independent display by HDMI, DVI-I or iDP interfaces
- SATA 6Gb/s and USB 3.0 supported
- One PCIe Mini slot with mSATA support
- One PCIe x16 slot
- Six PCI slots
- Five COM ports (four RS-232 and one RS-232/422/485)
- TPM V1.2 hardware security function supported by TPM module
- High Definition Audio
- RoHS compliant

1.3 Connectors

The connectors on the IMBA-H110 are shown in the figure below.

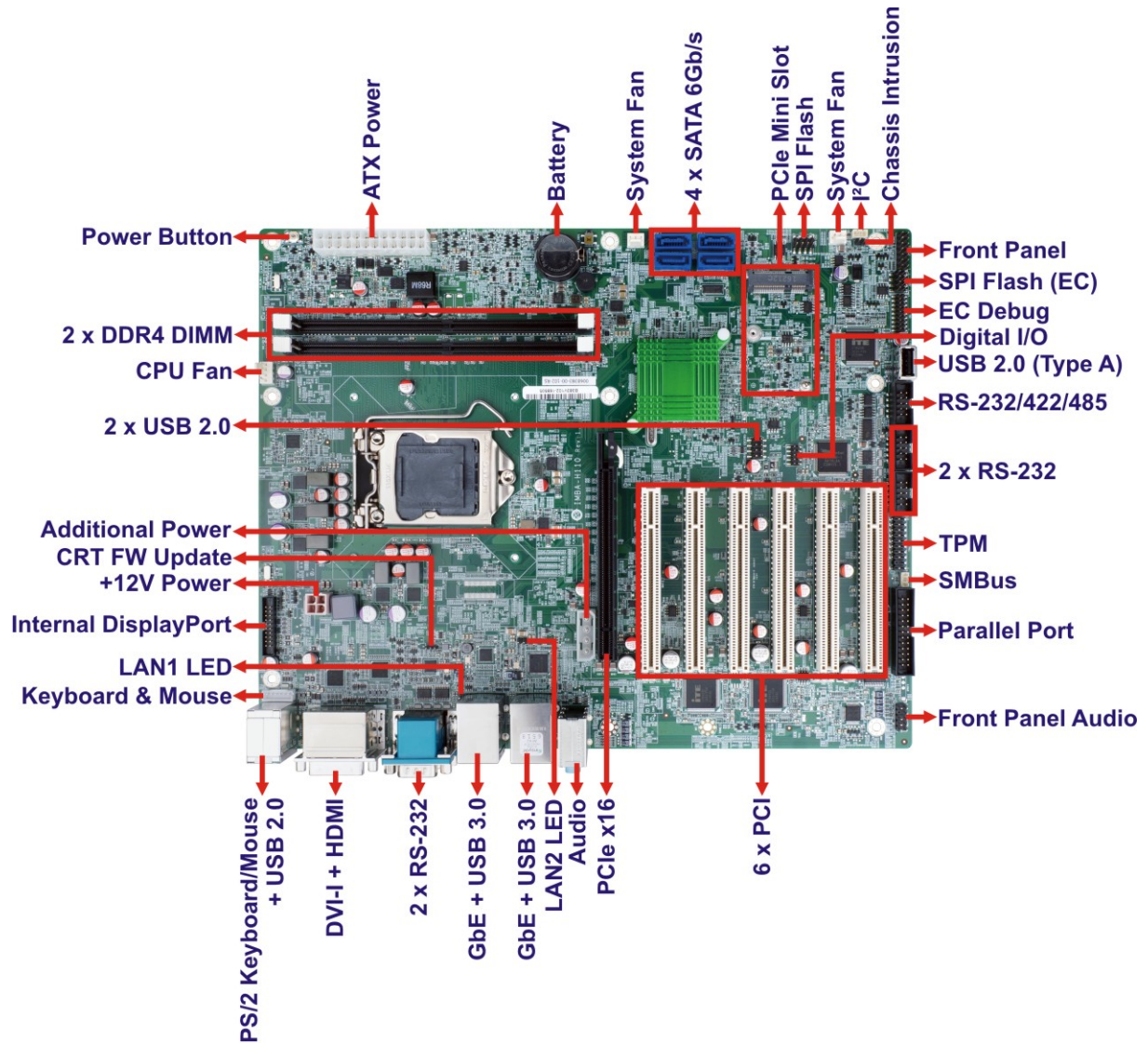

Figure 1-2: Connectors

IMBA-H110 ATX Motherboard

1.4 Dimensions

The main dimensions of the IMBA-H110 are shown in the diagram below.

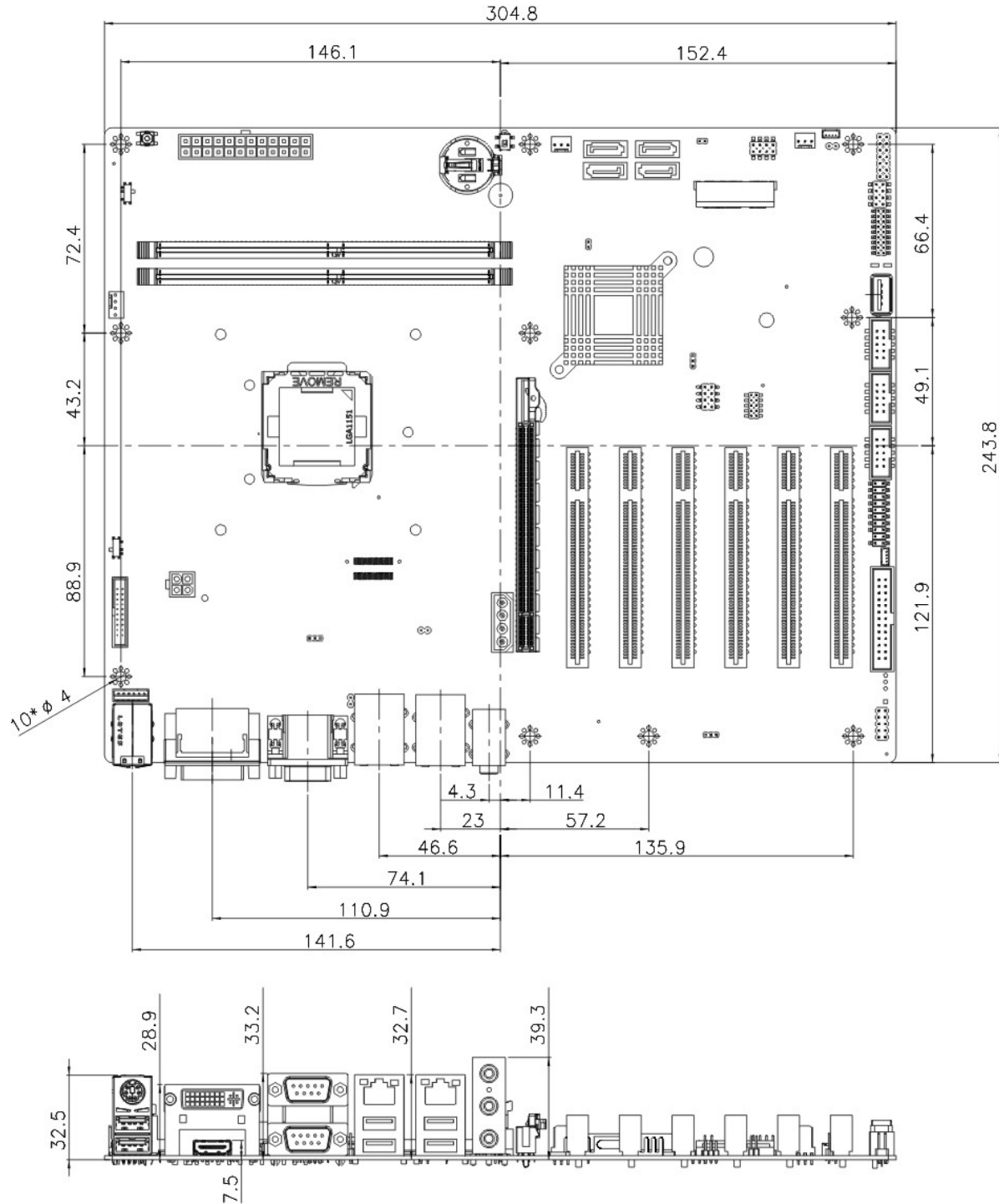

Figure 1-3: IMBA-H110 Dimensions (mm)

1.5 Data Flow

Figure 1-4 shows the data flow between the system chipset, the CPU and other components installed on the motherboard.

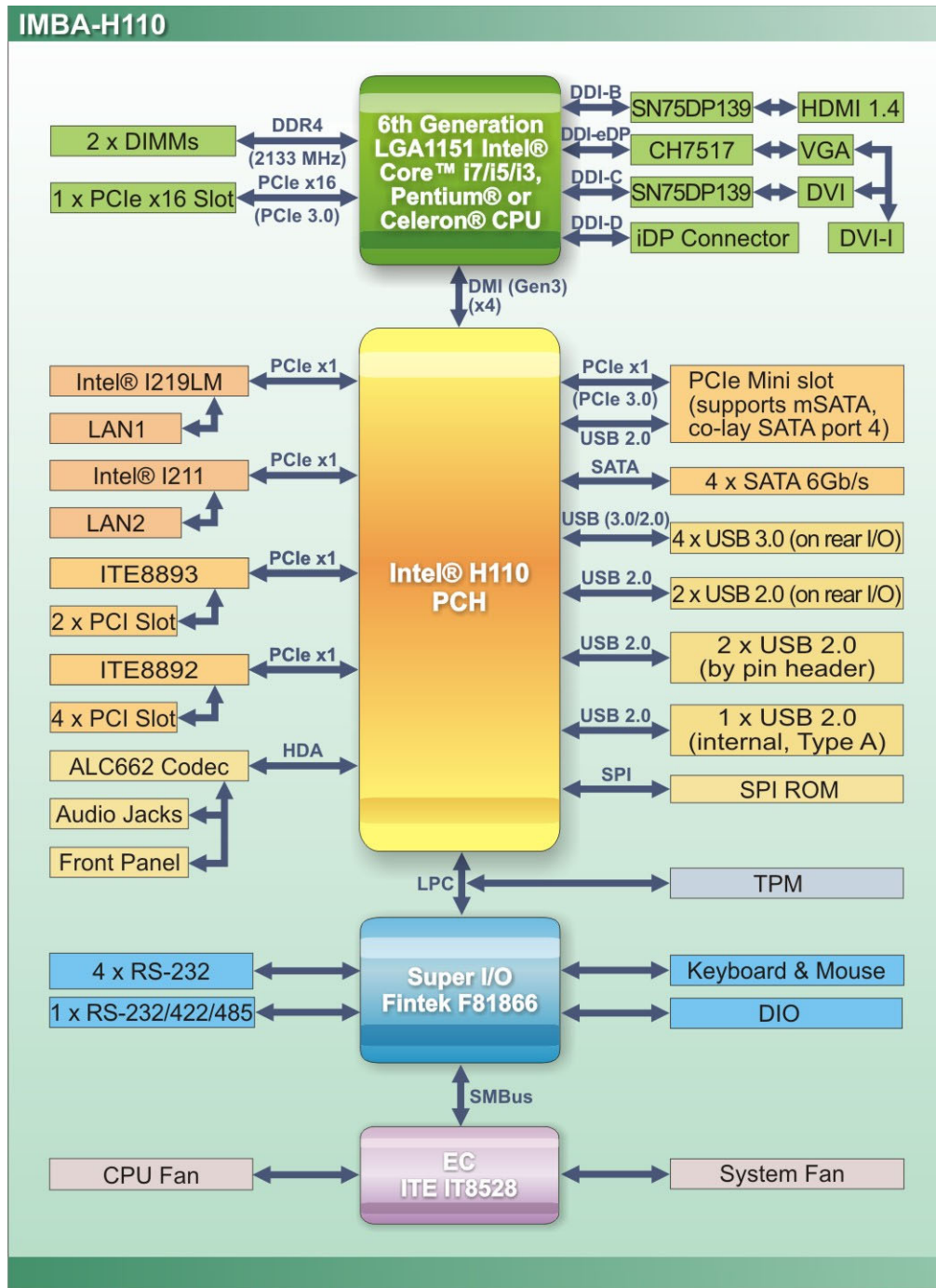

Figure 1-4: Data Flow Diagram

IMBA-H110 ATX Motherboard

1.6 Technical Specifications

The IMBA-H110 technical specifications are listed below.

Specification/Model	IMBA-H110
Form Factor	ATX
CPU Supported	6th generation LGA1151 Intel® Core™ i7/i5/i3, Pentium® or Celeron® CPU
PCH	Intel® H110
Memory	Two 288-pin 2133 MHz dual-channel unbuffered DDR4 SDRAM DIMMs supported (system max. 64 GB)
Graphics Engine	Intel® HD Graphics Gen9 engine with 16 low-power execution units, supporting DX2015, OpenGL 5.x, OpenCL 2.x and ES 2.0
Display Output	Dual independent display One DVI-I (up to 1920x1200@60 Hz) One HDMI 1.4 (up to 3840x2160@60 Hz) One iDP interface for HDMI, LVDS, VGA, DVI and DisplayPort (up to 1920x1200@60 Hz)
Audio	Realtek ALC662 HD Audio codec supports 5.1 channels
BIOS	AMI UEFI BIOS
Ethernet Controllers	LAN1_USB1: Intel® I219LM LAN2_USB2: Intel® I211
Super I/O Controller	Fintek F81866
Watchdog Timer	Software programmable supports 1~255 sec. system reset
Expansions	One full-size/half-size PCIe Mini card slot (supports mSATA) One PCIe x16 slot (Gen3) Six PCI slots
I/O Interface Connectors	
Audio Connectors	Line-in, line-out and mic-in audio jacks on rear panel One internal front panel audio connector (10-pin header)

Chassis Intrusion	One 2-pin header
Digital I/O	8-bit digital I/O
Ethernet	Two RJ-45 GbE ports
Fan	One 4-pin CPU smart fan connector Two 3-pin system fan connectors
Front Panel	One 14-pin header (power LED, HDD LED, speaker, power button, reset button)
I²C	One 4-pin wafer connector
Keyboard and Mouse	One PS/2 keyboard/mouse connector One internal keyboard and mouse connector (6-pin wafer)
LAN LEDs	Two 2-pin headers
Parallel Port	One parallel port via internal 26-pin box header
Serial ATA	Four SATA 6Gb/s connectors (support hot plug)
Serial Ports	Two external RS-232 serial ports Two RS-232 via internal box headers One RS-232/422/485 via internal box header
SMBus	One 4-pin wafer connector
TPM	One via 20-pin header
USB 2.0	One USB 2.0 port by internal Type A connector Two USB 2.0 ports on rear panel Two USB 2.0 ports via internal pin header
USB 3.0	Four USB 3.0 ports on rear panel * The Windows® 7 installation media does not include native driver support for USB 3.0. In order to use the USB keyboard or mouse connected to a USB 3.0 port during OS installation, the user has to update the Windows® 7 installation image so that it contains USB 3.0 drivers. Please refer to Section 4.10 for detailed installation procedures.

IMBA-H110 ATX Motherboard

Environmental and Power Specifications	
Power Supply	AT/ATX power supply
Power Consumption	3.3V@1.53A, 5V@2.95A, 12V@8.38A, 5VSB@3.2A (4.0 GHz Intel® Core™ i7-6700K CPU with two 8 GB 2133 MHz DDR4 memory)
Operating Temperature	-20°C ~ 60°C
Storage Temperature	-30°C ~ 70°C
Operating Humidity	5% ~ 95% (non-condensing)
Physical Specifications	
Dimensions	244 mm x 305 mm
Weight (GW/NW)	1200 g/700 g

Table 1-1: IMBA-H110 Specifications

Chapter

2

Packing List

IMBA-H110 ATX Motherboard

2.1 Anti-static Precautions



WARNING!

Static electricity can destroy certain electronics. Make sure to follow the ESD precautions to prevent damage to the product, and injury to the user.

Make sure to adhere to the following guidelines:

- **Wear an anti-static wristband:** Wearing an anti-static wristband can prevent electrostatic discharge.
- **Self-grounding:** Touch a grounded conductor every few minutes to discharge any excess static buildup.
- **Use an anti-static pad:** When configuring any circuit board, place it on an anti-static mat.
- **Only handle the edges of the PCB:** Don't touch the surface of the motherboard. Hold the motherboard by the edges when handling.

2.2 Unpacking Precautions

When the IMBA-H110 is unpacked, please do the following:

- Follow the anti-static guidelines above.
- Make sure the packing box is facing upwards when opening.
- Make sure all the packing list items are present.







2.3 Packing List

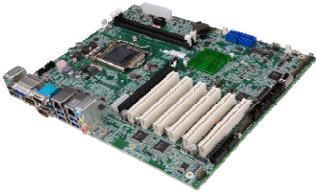

NOTE:

If any of the components listed in the checklist below are missing, do not proceed with the installation. Contact the IEI reseller or vendor the IMBA-H110 was purchased from or contact an IEI sales representative directly by sending an email to sales@ieiworld.com.

The IMBA-H110 is shipped with the following components:

Quantity	Item and Part Number	Image
1	IMBA-H110 single board computer	
1	I/O shielding	
2	SATA cable	
1	Standoff and screw (for half-size PCIe Mini card)	
1	Utility CD	
1	One Key Recovery CD	

IMBA-H110 ATX Motherboard



Quantity	Item and Part Number	Image
1	Quick installation guide	

Table 2-1: Packing List

2.4 Optional Items

The following are optional components which may be separately purchased:

Item and Part Number	Image
LPT cable (P/N: 19800-000049-RS)	
Dual RS-232 cable, 230 mm, P=2.54 (P/N: 19800-000051-RS)	
PS/2 KB/MS Y-cable with bracket, 220 mm (P/N: 19800-000075-RS)	
SATA power cable (P/N: 32102-000100-200-RS)	
LGA1155/LGA1156 cooler kit (1U chassis compatible, 73W) (P/N: CF-1156A-RS-R11)	
LGA1155/LGA1156 cooler kit (1U chassis compatible, 45W) (P/N: CF-1156C-RS)	

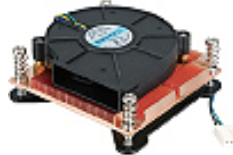







Item and Part Number	Image
LGA1155/LGA1156 cooler kit (1U chassis compatible, 65W) (P/N: CF-1156D-RS)	
LGA1155/LGA1156 cooler kit (95W) (P/N: CF-1156E-R11)	
DisplayPort to HDMI converter board (for IEI iDP connector) (P/N: DP-HDMI-R10)	
DisplayPort to LVDS converter board (for IEI iDP connector) (P/N: DP-LVDS-R10)	
DisplayPort to VGA converter board (for IEI iDP connector) (P/N: DP-VGA-R10)	
DisplayPort to DVI-D converter board (for IEI iDP connector) (P/N: DP-DVI-R10)	
DisplayPort to DisplayPort converter board (for IEI iDP connector) (P/N: DP-DP-R10)	
20-pin Infineon TPM module, software management tool, firmware v3.17 (P/N: TPM-IN01-R11)	

Table 2-2: Optional Items

Chapter

3

Connectors

3.1 Peripheral Interface Connectors

This chapter details all the peripheral interface connectors.

3.1.1 IMBA-H110 Layout

The figure below shows all the peripheral interface connectors.

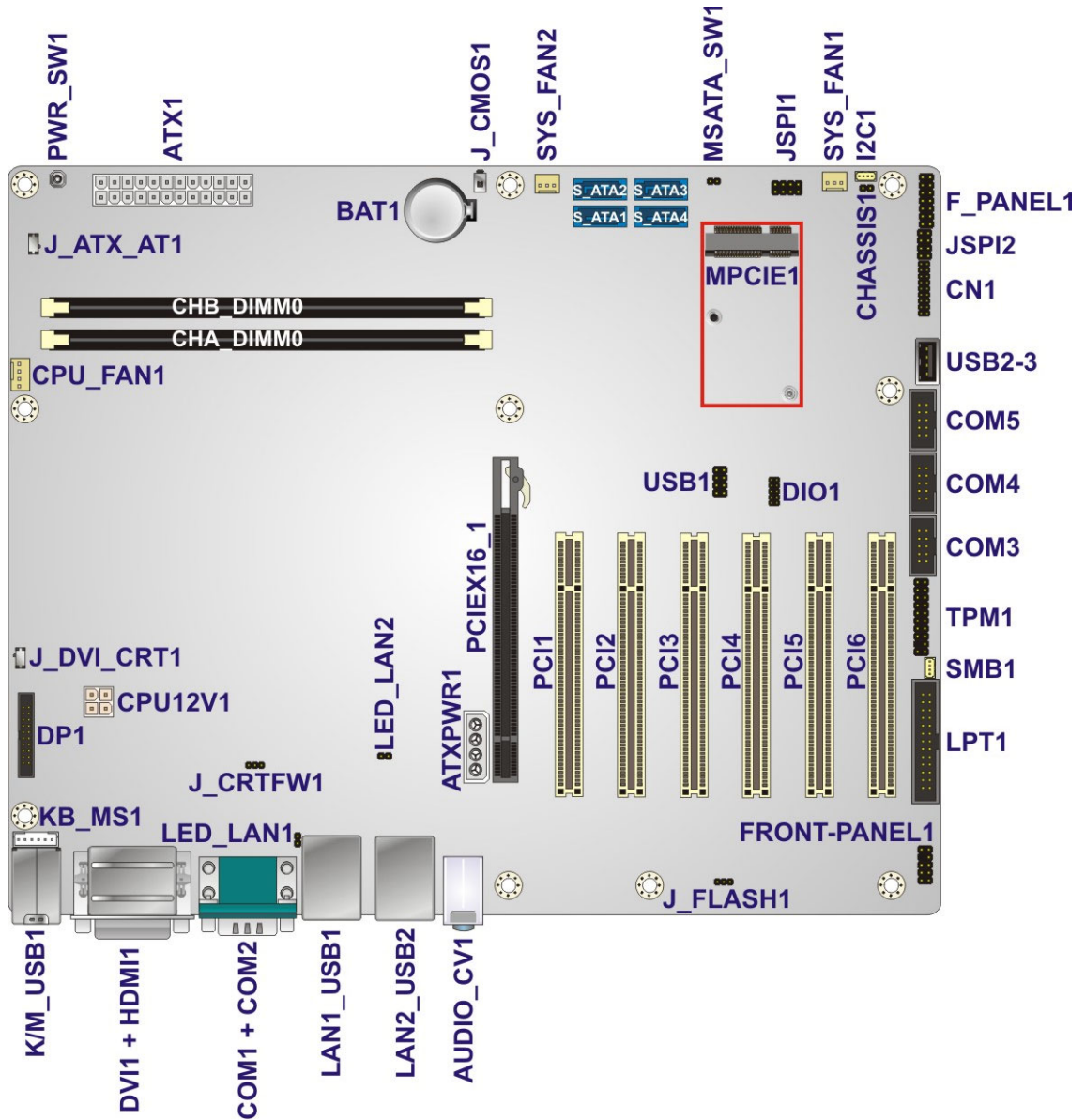

Figure 3-1: Peripheral Interface Connectors

IMBA-H110 ATX Motherboard

3.1.2 Peripheral Interface Connectors

The table below lists all the connectors on the board.

Connector	Type	Label
+12V power connector	4-pin Molex power connector	CPU12V1
Additional power connector	4-pin connector	ATXPWR1
ATX power connector	24-pin connector	ATX1
Battery connector	Battery holder	BAT1
Chassis intrusion connector	2-pin header	CHASSIS1
CRT FW update	3-pin header	J_CRTFW1
DDR4 DIMM sockets	288-pin socket	CHA_DIMM0, CHB_DIMM0
Digital I/O connector	10-pin header	DIO1
EC debug connector	18-pin header	CN1
Fan connector (CPU)	4-pin wafer	CPU_FAN1
Fan connectors (system)	3-pin wafer	SYS_FAN1, SYS_FAN2
Front panel audio connector	10-pin header	FRONT-PANEL1
Front panel connector	14-pin header	F_PANEL1
I ² C connector	4-pin wafer	I2C1
Internal DisplayPort connector	20-pin box header	DP1
Keyboard and mouse connector	6-pin wafer	KB_MS1
LAN LED connectors	2-pin header	LED_LAN1, LED_LAN2
Parallel port connector	26-pin box header	LPT1
PCI slots	PCI slot	PCI1, PCI2, PCI3, PCI4, PCI5, PCI6
PCIe x16 slot	PCIe x16 slot	PCIEX16_1

Connector	Type	Label
PCIe Mini slot	PCIe Mini slot	MPCIE1
Power button	Push button	PWR_SW1
SATA 6Gb/s drive connector	7-pin SATA connector	S_ATA1, S_ATA2, S_ATA3, S_ATA4
RS-232 serial ports	10-pin box header	COM3, COM4
RS-232/422/485 serial port	10-pin box header	COM5
SMBus connector	4-pin wafer	SMB1
SPI flash connector	8-pin header	JSPI1
SPI flash connector, EC	8-pin header	JSPI2
TPM connector	20-pin header	TPM1
USB 2.0 connector (Type A)	Type A	USB2-3
USB 2.0 connector	8-pin header	USB1

Table 3-1: Peripheral Interface Connectors

3.1.3 External Interface Panel Connectors

The table below lists the connectors on the external I/O panel.

Connector	Type	Label
Audio connector	Audio jacks	AUDIO_CV1
Ethernet and USB 3.0 connectors	RJ-45, USB 3.0	LAN1_USB1, LAN2_USB2
Keyboard/mouse and USB 2.0 connectors	PS/2, USB 2.0	K/M_USB1
DVI-I and HDMI connectors	24-pin female, HDMI 1.4	DVI1, HDMI1
Serial port connectors	9-pin male DB-9	COM1

Table 3-2: Rear Panel Connectors

IMBA-H110 ATX Motherboard

3.2 Internal Peripheral Connectors

The section describes all of the connectors on the IMBA-H110.

3.2.1 +12V Power Connector

- CN Label:** CPU12V1
- CN Type:** 4-pin Molex power connector, p=4.2 mm
- CN Location:** See **Figure 3-2**
- CN Pinouts:** See **Table 3-3**

This connector provides power to the CPU.

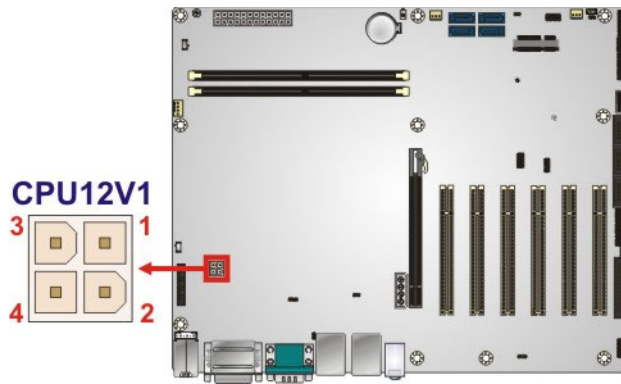

Figure 3-2: +12V Power Connector Pinout Location

Pin	Description	Pin	Description
1	GND	2	GND
3	+12V	4	+12V

Table 3-3: +12V Power Connector Pinouts

3.2.2 Additional Power Connector

- CN Label:** ATPWR1
- CN Type:** 4-pin connector, p=5.08 mm
- CN Location:** See **Figure 3-3**
- CN Pinouts:** See **Table 3-4**

The additional power connector provides extra +12V and +5V power to the system.

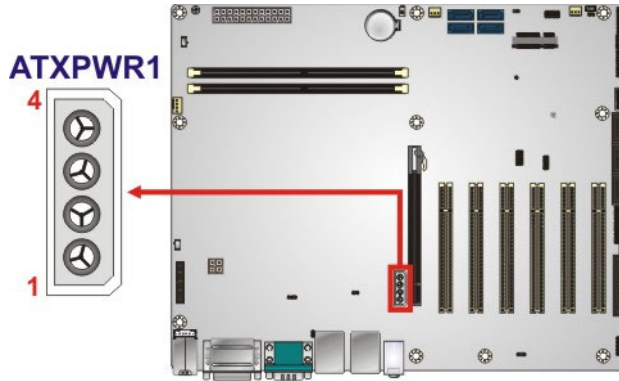

Figure 3-3: Additional Power Connector Location

Pin	Description
1	+12V
2	GND
3	GND
4	+5V

Table 3-4: Additional Power Connector Pinouts

3.2.3 ATX Power Connector

- CN Label:** ATX1
- CN Type:** 24-pin connector, p=4.2 mm
- CN Location:** See **Figure 3-4**
- CN Pinouts:** See **Table 3-5**

The ATX power connector connects to an ATX power supply.

IMBA-H110 ATX Motherboard

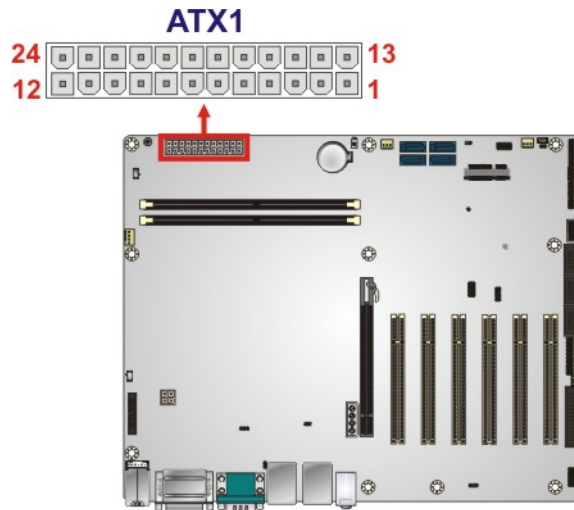

Figure 3-4: ATX Power Connector Location

Pin	Description	Pin	Description
1	+3.3V	13	+3.3V
2	+3.3V	14	-12V
3	GND	15	GND
4	+5V	16	PS_ON
5	GND	17	GND
6	+5V	18	GND
7	GND	19	GND
8	Power good	20	-5V
9	5VSB	21	+5V
10	+12V	22	+5V
11	+12V	23	+5V
12	+3.3V	24	GND

Table 3-5: ATX Power Connector Pinouts

3.2.4 Battery Connector

**CAUTION:**

Risk of explosion if battery is replaced by an incorrect type. Only certified engineers should replace the on-board battery.

Dispose of used batteries according to instructions and local regulations.

CN Label:	BAT1
CN Type:	Battery holder
CN Location:	See Figure 3-5

A system battery is placed in the battery holder. The battery provides power to the system clock to retain the time when power is turned off.

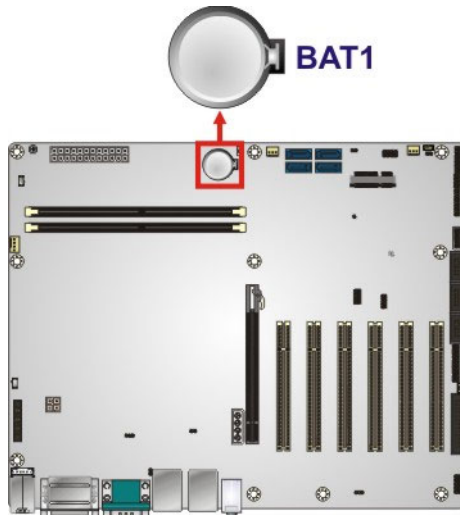

Figure 3-5: Battery Connector Location

IMBA-H110 ATX Motherboard

3.2.5 Chassis Intrusion Connector

- CN Label:** CHASSIS1
- CN Type:** 2-pin header, p=2.54 mm
- CN Location:** See **Figure 3-6**
- CN Pinouts:** See **Table 3-6**

The chassis intrusion connector is for a chassis intrusion detection sensor or switch that detects if a chassis component is removed or replaced.

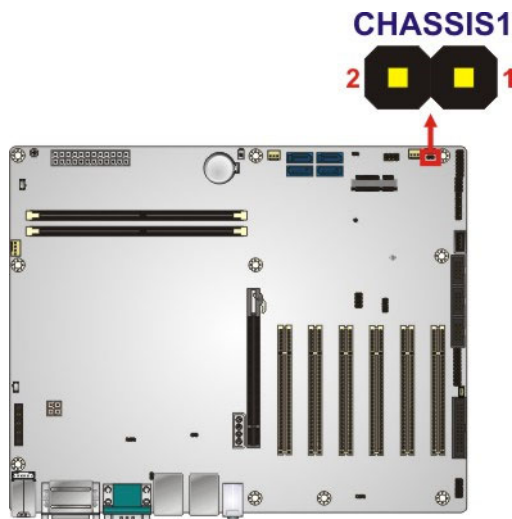

Figure 3-6: Chassis Intrusion Connector Location

Pin	Description
1	+VRTC
2	CHASSIS OPEN

Table 3-6: Chassis Intrusion Connector Pinouts

3.2.6 CRT FW Update Connector

- CN Label:** J_CRTFW1
- CN Type:** 3-pin header, p=2.00 mm
- CN Location:** See **Figure 3-7**
- CN Pinouts:** See **Table 3-7**

The CRT FW update connector is used to update the CRT firmware.



Figure 3-7: CRT FW Update Connector Location

Pin	Description
1	SPC
2	SPD
3	GND

Table 3-7: CRT FW Update Connector Pinouts

3.2.7 DDR4 DIMM Slots

- CN Label:** CHA_DIMM0, CHB_DIMM0
- CN Type:** DDR4 DIMM slot
- CN Location:** See **Figure 3-8**

The DIMM slots are for DDR4 DIMM memory modules.

IMBA-H110 ATX Motherboard

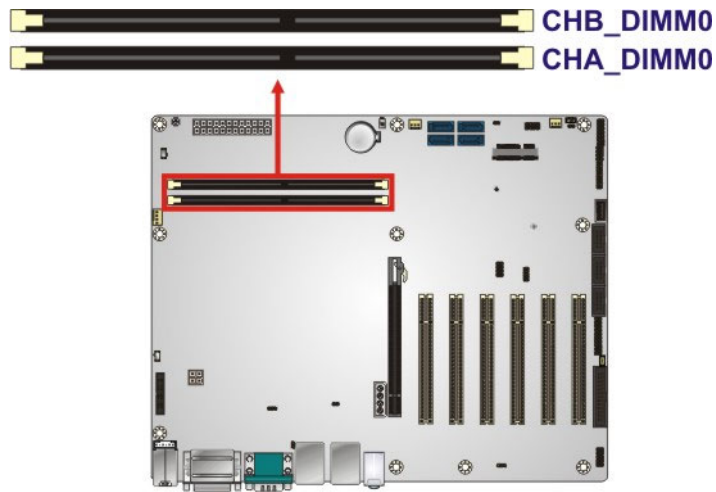

Figure 3-8: DDR4 DIMM Slot Locations

3.2.8 Digital I/O Connector

CN Label:	DIO1
CN Type:	10-pin header, p=2.00 mm
CN Location:	See Figure 3-9
CN Pinouts:	See Table 3-8

The digital I/O connector provides programmable input and output for external devices.

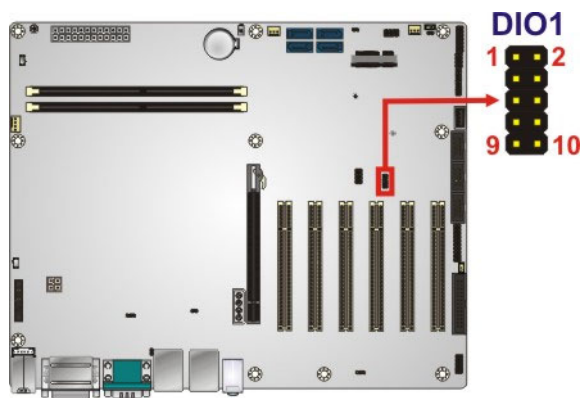

Figure 3-9: Digital I/O Connector Location

Pin	Description	Pin	Description
1	GND	2	VCC
3	Output 3	4	Output 2
5	Output 1	6	Output 0
7	Input 3	8	Input 2
9	Input 1	10	Input 0

Table 3-8: Digital I/O Connector Pinouts

3.2.9 EC Debug Connector

- CN Label:** CN1
- CN Type:** 18-pin header, p=2 mm
- CN Location:** See **Figure 3-10**
- CN Pinouts:** See **Table 3-9**

The EC debug connector is used for EC debug.

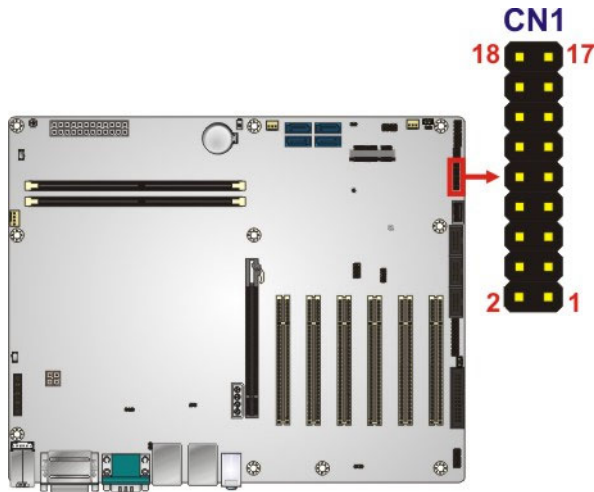

Figure 3-10: EC Debug Connector Location

Pin	Description	Pin	Description
1	EC_EPP_STB#	2	EC_EPP_AFD#
3	EC_EPP_PDO	4	NC
5	EC_EPP_PD1	6	EC_EPP_INIT#

IMBA-H110 ATX Motherboard

Pin	Description	Pin	Description
7	EC_EPP_PD2	8	EC_EPP_SLIN#
9	EC_EPP_PD3	10	GND
11	EC_EPP_PD4	12	NC
13	EC_EPP_PD5	14	EC_EPP_BUSY
15	EC_EPP_PD6	16	EC_EPP_KSI5
17	EC_EPP_PD7	18	EC_EPP_KSI4

Table 3-9: EC Debug Connector Pinouts

3.2.10 Fan Connector (CPU)

- CN Label:** CPU_FAN1
- CN Type:** 4-pin wafer, p=2.54 mm
- CN Location:** See **Figure 3-11**
- CN Pinouts:** See **Table 3-10**

The fan connector attaches to a CPU cooling fan.

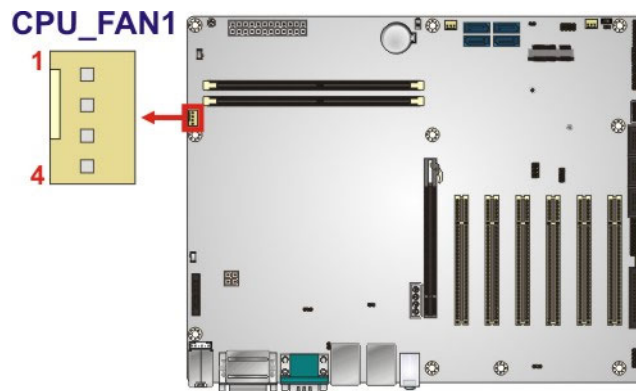

Figure 3-11: CPU Fan Connector Location

Pin	Description
1	GND
2	+12V
3	FANIO
4	PWM

Table 3-10: CPU Fan Connector Pinouts

3.2.11 Fan Connectors (System)

CN Label: SYS_FAN1, SYS_FAN2

CN Type: 3-pin wafer, p=2.54 mm

CN Location: See **Figure 3-12**

CN Pinouts: See **Table 3-11**

Each fan connector attaches to a system cooling fan.

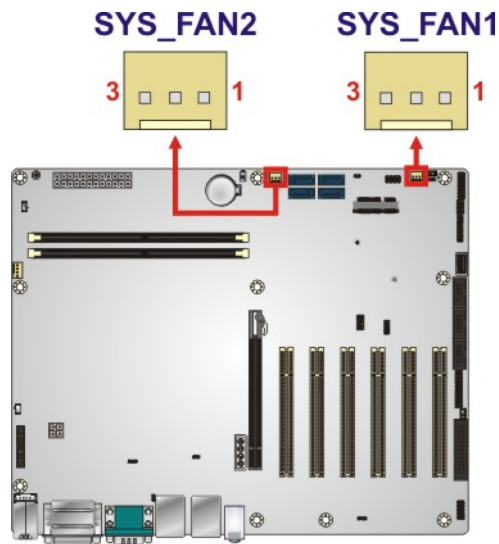

Figure 3-12: System Fan Connector Locations

Pin	Description
1	FANIO
2	+12V (PWM)
3	GND

Table 3-11: System Fan Connector Pinouts

IMBA-H110 ATX Motherboard

3.2.12 Front Panel Audio Connector

- CN Label:** FRONT-PANEL1
- CN Type:** 10-pin header, p=2.54 mm
- CN Location:** See **Figure 3-13**
- CN Pinouts:** See **Table 3-12**

This connector connects to speakers, a microphone and an audio input.

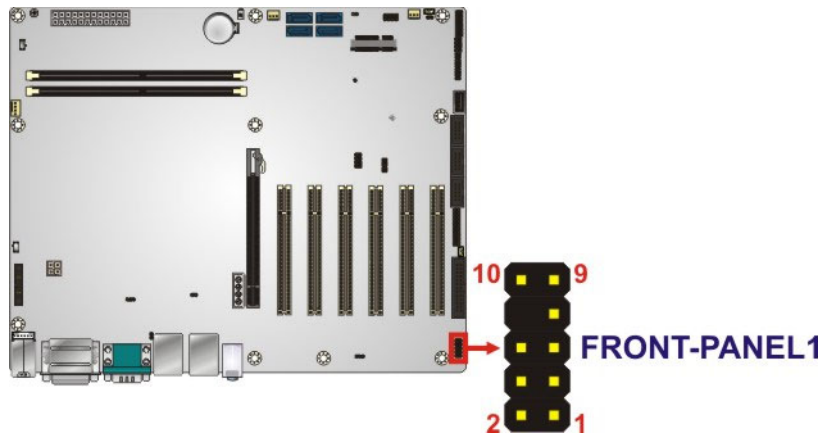

Figure 3-13: Front Panel Audio Connector Location

Pin	Description	Pin	Description
1	MIC2-L	2	GND
3	MIC2-R	4	Presence#
5	LINE2-R	6	MIC2-JD
7	FRONT-IO	8	NC
9	LINE2-L	10	LINE2-JD

Table 3-12: Front Panel Audio Connector Pinouts

3.2.13 Front Panel Connector

- CN Label:** F_PANEL1
- CN Type:** 14-pin header, p=2.54 mm
- CN Location:** See **Figure 3-14**
- CN Pinouts:** See **Table 3-13**

The front panel connector connects to the indicator LEDs and buttons on the computer's front panel.

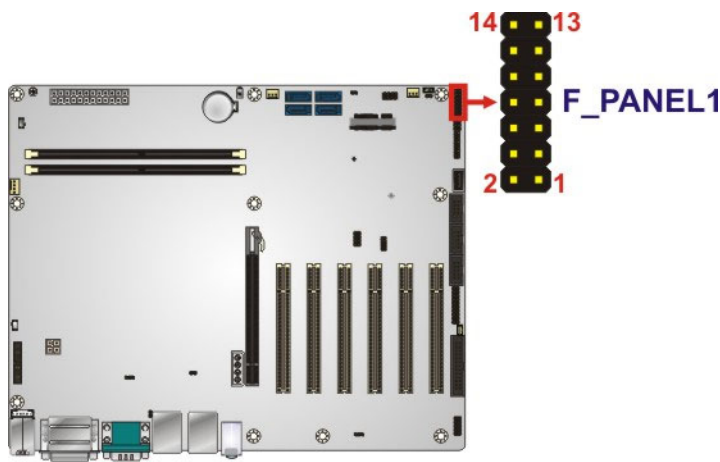

Figure 3-14: Front Panel Connector Location

Function	Pin	Description	Function	Pin	Description
Power LED	1	+5V	Speaker	2	BEEP_PWR
	3	NC		4	NC
	5	GND		6	NC
Power Button	7	PWRBTN_SW#		8	PC_BEEP
	9	GND		10	NC
HDD LED	11	+5V	Reset	12	EXTRST-
	13	SATA_LED#		14	GND

Table 3-13: Front Panel Connector Pinouts

IMBA-H110 ATX Motherboard

3.2.14 I²C Connector

- CN Label:** I2C1
- CN Type:** 4-pin wafer, p=1.25 mm
- CN Location:** See **Figure 3-15**
- CN Pinouts:** See **Table 3-14**

The I²C connector is used to connect I²C-bus devices to the mainboard.

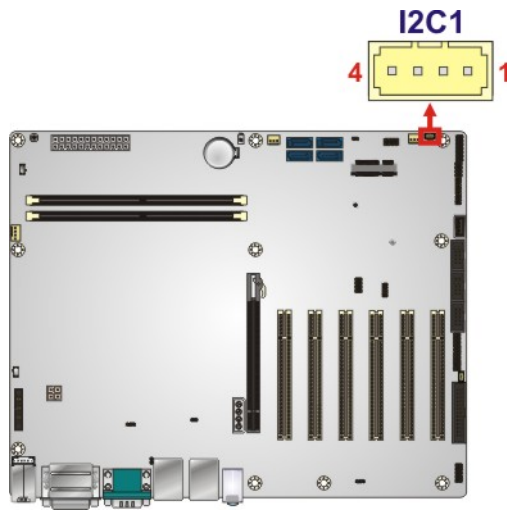

Figure 3-15: I²C Connector Location

Pin	Description
1	GND
2	I2C_DAT
3	I2C_CLK
4	+5V

Table 3-14: I²C Connector Pinouts

3.2.15 Internal DisplayPort Connector

- CN Label:** DP1
- CN Type:** 20-pin box header, p=2.00 mm
- CN Location:** See **Figure 3-16**
- CN Pinouts:** See **Table 3-15**

The DisplayPort connector supports HDMI, LVDS, VGA, DVI and DisplayPort graphics interfaces.

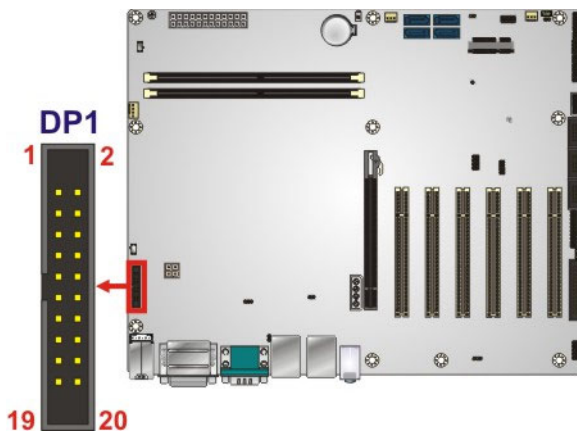

Figure 3-16: Internal DisplayPort Connector Location

Pin	Description	Pin	Description
1	HPD	2	AUX_P
3	GND	4	AUX_N
5	AUX_DET	6	GND
7	GND	8	LANE2P
9	LANE3P	10	LANE2N
11	LANE3N	12	GND
13	GND	14	LANE0P
15	LANE1P	16	LANE0N
17	LANE1N	18	VCC3V
19	VCC5V	20	NC

Table 3-15: Internal DisplayPort Connector Pinouts

IMBA-H110 ATX Motherboard

3.2.16 Keyboard and Mouse Connector

- CN Label:** KB_MS1
- CN Type:** 6-pin wafer, p=2 mm
- CN Location:** See **Figure 3-17**
- CN Pinouts:** See **Table 3-16**

The keyboard and mouse connector connects to a PS/2 Y-cable that can be connected to a PS/2 keyboard and mouse.

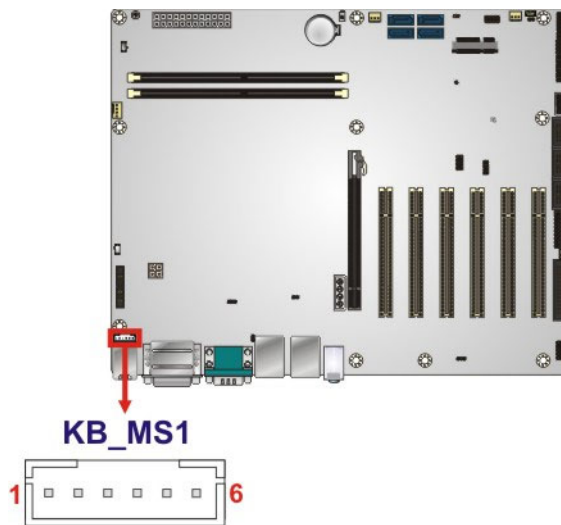

Figure 3-17: Keyboard and Mouse Connector Location

Pin	Description
1	VCC
2	Mouse Data
3	Mouse Clock
4	Keyboard Data
5	Keyboard Clock
6	GND

Table 3-16: Keyboard and Mouse Connector Pinouts

3.2.17 LAN LED Connectors

CN Label: LED_LAN1, LED_LAN2

CN Type: 2-pin header, p=2.54 mm

CN Location: See **Figure 3-18**

CN Pinouts: See **Table 3-17**

The LAN LED connectors are used to connect to the LAN LED indicators on the chassis to indicate users the link activities of the two LAN ports.

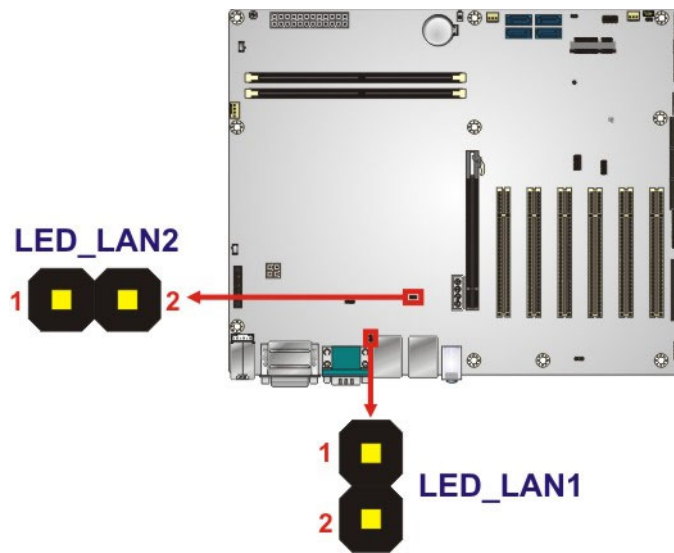

Figure 3-18: LAN1 LED Connector Location

Pin	Description
1	+3.3V
2	LAN_LED_LINK#_ACT

Table 3-17: LAN LED Connector Pinouts

IMBA-H110 ATX Motherboard

3.2.18 Parallel Port Connector

- CN Label:** LPT1
- CN Type:** 26-pin box header, p=2.54 mm
- CN Location:** See **Figure 3-19**
- CN Pinouts:** See **Table 3-18**

The parallel port connector connects to a parallel port connector interface or some other parallel port device such as a printer.

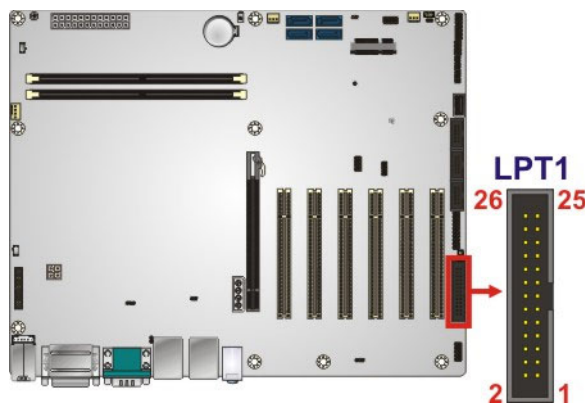

Figure 3-19: Parallel Port Connector Location

Pin	Description	Pin	Description
1	RSTROBE#	2	SIO_AFD#
3	RPD0	4	SIO_ERR#
5	RPD1	6	SIO_INIT#
7	RPD2	8	SIO_SLIN#
9	RPD3	10	GND
11	RPD4	12	GND
13	RPD5	14	GND
15	RPD6	16	GND
17	RPD7	18	GND
19	SIO_ACK#	20	GND
21	SIO_BUSY	22	GND
23	SIO_PE	24	GND
25	SIO_SLCT	26	N/C

Table 3-18: Parallel Port Connector Pinouts

3.2.19 PCI Slots

CN Label: PCI1, PCI2, PCI3, PCI4, PCI5, PCI6

CN Type: PCI Slot

CN Location: See **Figure 3-20**

Each PCI slot enables a PCI expansion module to be connected to the board.

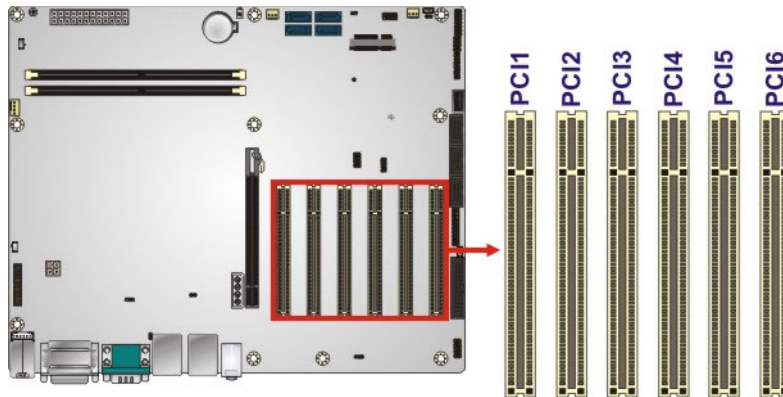

Figure 3-20: PCI Slot Locations

IMBA-H110 ATX Motherboard

3.2.20 PCI Express x16 Slot

CN Label:	PCIEX16_1
CN Type:	PCIe x16 slot
CN Location:	See Figure 3-21

The PCIe x16 expansion card slot is for PCIe x16 expansion card.

PCIEX16_1

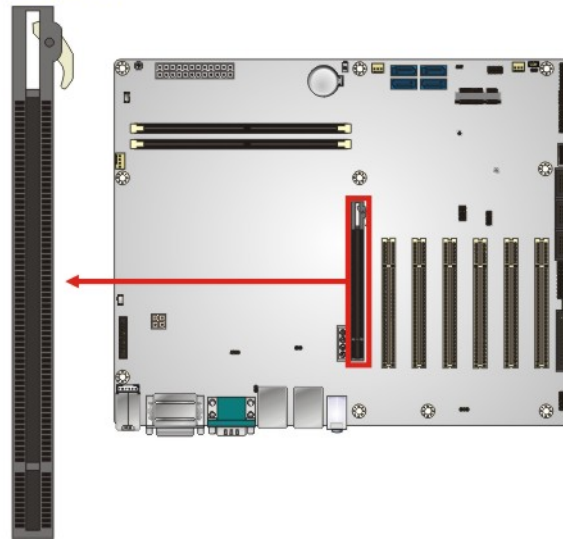

Figure 3-21: PCIe x16 Slot Location

3.2.21 PCIe Mini Slot

CN Label:	MPCIE1
CN Type:	PCIe Mini slot
CN Location:	See Figure 3-22
CN Pinouts:	See Table 3-19

The PCIe Mini slot is for installing a full-size/half-size PCIe Mini expansion card, including an mSATA card.



NOTE:

If the user shorts the mSATA setup jumper (MSATA_SW1) to force the system to enable mSATA device or an mSATA device is detected, the S_ATA4 connector will be disabled. Please refer to **Section 4.8.5**.

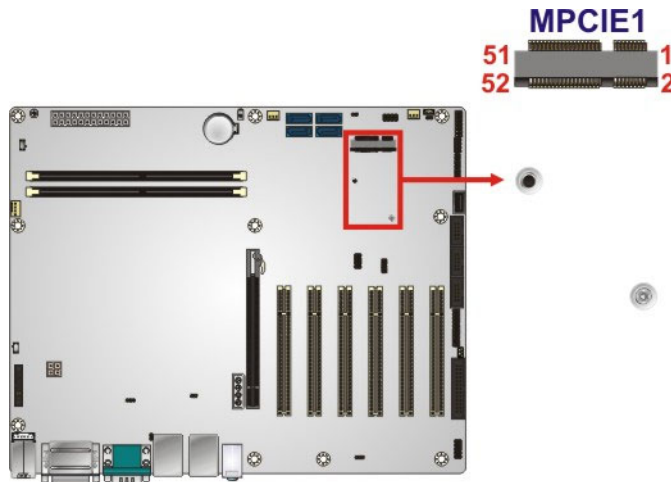

Figure 3-22: PCIe Mini Slot Location

Pin	Description	Pin	Description
1	PCIE_WAKE#	2	+3.3V
3	N/C	4	GND
5	N/C	6	1.5V
7	N/C	8	N/C
9	GND	10	N/C
11	MSATA_CLK#	12	N/C
13	MSATA_CLK	14	N/C
15	GND	16	N/C
17	PLTRST_N	18	GND
19	N/C	20	+3.3V
21	GND	22	PLTRST_N
23	SATA_RX-/PCIE_RX-	24	+3.3V
25	SATA_RX+/PCIE_RX+	26	GND
27	GND	28	1.5V

IMBA-H110 ATX Motherboard

Pin	Description	Pin	Description
29	GND	30	SMB_CLK
31	SATA_TX-/PCIE_TX-	32	SMB_DATA
33	SATA_TX+/PCIE_TX+	34	GND
35	GND	36	USB_DATA-
37	GND	38	USB_DATA+
39	+3.3V	40	GND
41	+3.3V	42	N/C
43	+3.3V	44	N/C
45	CLINK_CLK	46	N/C
47	CLINK_DATA	48	1.5V
49	CLINK_RST#	50	GND
51	MSATA_DET	52	+3.3V

Table 3-19: PCIe Mini Slot Pinouts

3.2.22 Power Button

CN Label: PWR_SW1

CN Type: Push button

CN Location: See **Figure 3-23**

The on-board power button controls system power.

PWR_SW1

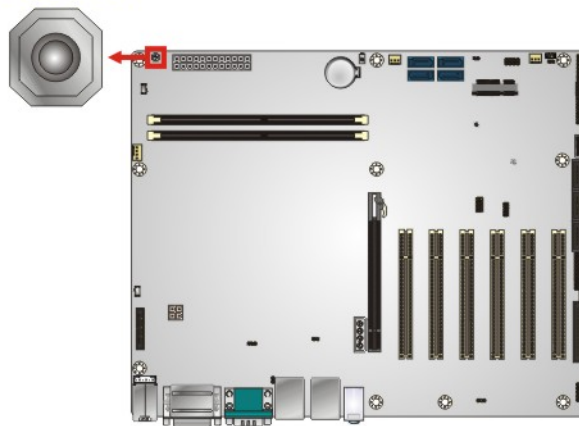

Figure 3-23: Power Button Location

3.2.23 RS-232 Serial Port Connector

- CN Label:** COM3, COM4
- CN Type:** 10-pin box header, p=2.54 mm
- CN Location:** See **Figure 3-24**
- CN Pinouts:** See **Table 3-20**

Each of these connectors provides RS-232 connections.

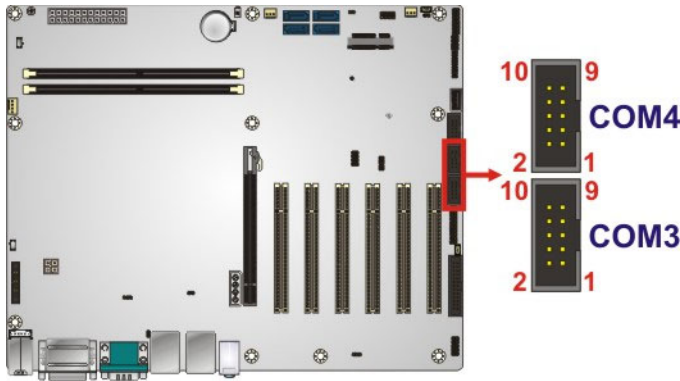

Figure 3-24: RS-232 Serial Port Connector Locations

Pin	Description	Pin	Description
1	DCD	2	DSR
3	RXD	4	RTS
5	TXD	6	CTS
7	DTR	8	RI
9	GND	10	GND

Table 3-20: RS-232 Serial Port Connector Pinouts

IMBA-H110 ATX Motherboard

3.2.24 RS-232/422/485 Serial Port Connector

- CN Label:** COM5
- CN Type:** 10-pin box header, p=2.54 mm
- CN Location:** See **Figure 3-25**
- CN Pinouts:** See **Table 3-21**

Each of these connectors provides RS-232, RS-422 or RS-485 communications.



NOTE:

The communication protocol of the serial port is set through the BIOS menu in “Advanced → Super IO Configuration → Serial Port 5 Configuration”. Use the **Transfer Mode** BIOS option to configure the correspondent serial ports (refer to **Sections 5.3.3.4.2** for detailed information).

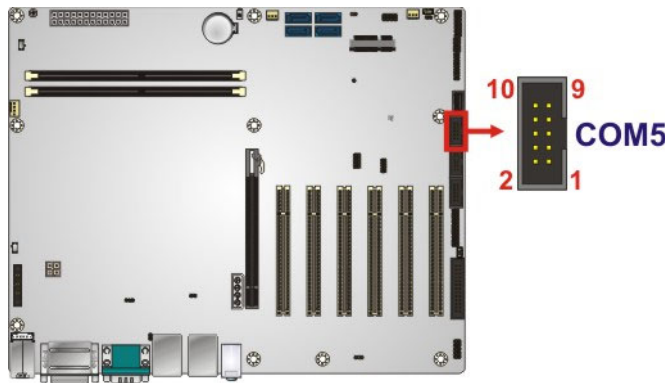

Figure 3-25: RS-232/422/485 Connector Location

Pin	Description	Pin	Description
1	DCD	2	DSR
3	RXD	4	RTS
5	TXD	6	CTS
7	DTR	8	RI
9	GND	10	GND

Table 3-21: RS-232/422/485 Connector Pinouts

Use an RS-232/422/485 cable to connect to a serial device. The pinouts of the DB-9 connector are listed below.

RS-232 Pinouts	RS-422 Pinouts	RS-485 Pinouts
<p>DSR(6) RTS(7) CTS(8) RI(9)</p>		

Table 3-22: DB-9 RS-232/422/485 Pinouts

3.2.25 SATA 6Gb/s Drive Connector

CN Label: S_ATA1, S_ATA2, S_ATA3, S_ATA4

CN Type: 7-pin SATA drive connector

CN Location: See **Figure 3-26**

CN Pinouts: See **Table 3-23**

The SATA drive connectors can be connected to SATA drives and support up to 6Gb/s data transfer rate.



NOTE:

If the user shorts the mSATA setup jumper (MSATA_SW1) to force the system to enable mSATA device or an mSATA device is detected, the S_ATA4 connector will be disabled. Please refer to **Section 4.8.5**.

IMBA-H110 ATX Motherboard

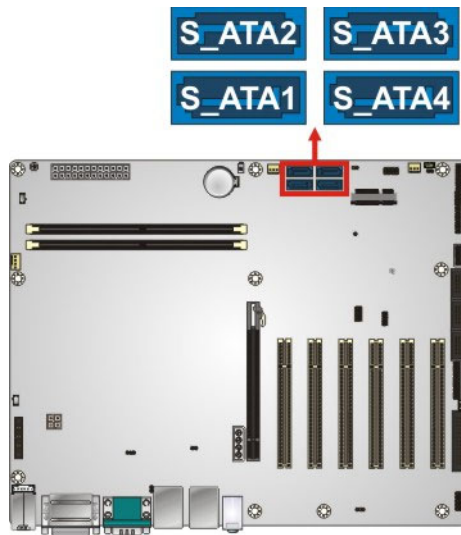

Figure 3-26: SATA 6Gb/s Drive Connector Location

Pin	Description
1	GND
2	SATA_TX+
3	SATA_TX-
4	GND
5	SATA_RX-
6	SATA RX+
7	GND

Table 3-23: SATA 6Gb/s Drive Connector Pinouts

3.2.26 SMBus Connector

- CN Label:** SMB1
- CN Type:** 4-pin wafer, p=1.25 mm
- CN Location:** See **Figure 3-27**
- CN Pinouts:** See **Table 3-24**

The SMBus (System Management Bus) connector provides low-speed system management communications.

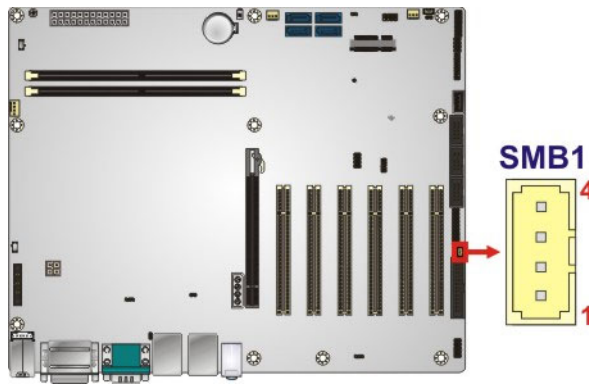

Figure 3-27: SMBus Connector Location

Pin	Description
1	GND
2	SMB_DATA
3	SMB_CLK
4	+5V

Table 3-24: SMBus Connector Pinouts

IMBA-H110 ATX Motherboard

3.2.27 SPI Flash Connector

- CN Label:** JSPI1
- CN Type:** 8-pin header, p=2.54 mm
- CN Location:** See **Figure 3-28**
- CN Pinouts:** See **Table 3-25**

The SPI flash connector is used to flash the SPI ROM.

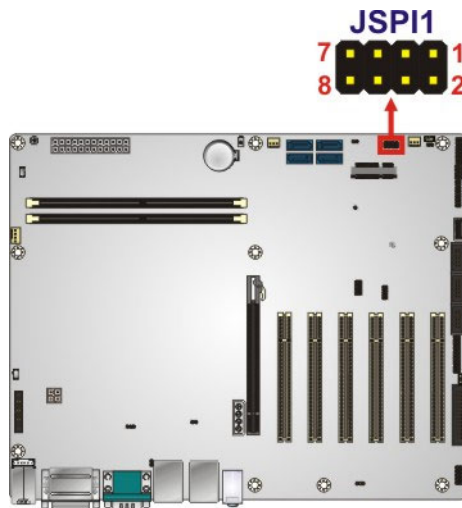

Figure 3-28: SPI Flash Connector Location

Pin	Description	Pin	Description
1	+3.3V	2	GND
3	SPI_CS	4	SPI_CLK
5	SPI_SO	6	SPI_SI
7	NC	8	NC

Table 3-25: SPI Flash Connector Pinouts

3.2.28 SPI Flash Connector, EC

- CN Label:** JSPI2
- CN Type:** 8-pin header, p=2.54 mm
- CN Location:** See **Figure 3-29**
- CN Pinouts:** See **Table 3-26**

The SPI flash connector is used to flash the EC ROM.

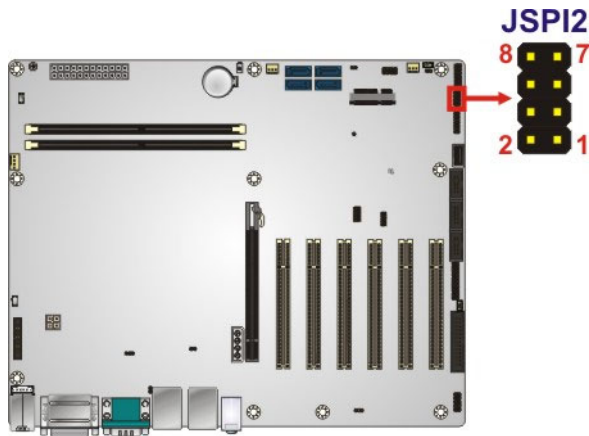

Figure 3-29: SPI EC Flash Connector Location

Pin	Description	Pin	Description
1	+3.3V_EC	2	GND
3	SPI_CS_EC	4	SPI_CLK_EC
5	SPI_SO_EC	6	SPI_SI_EC
7	NC	8	NC

Table 3-26: SPI EC Flash Connector Pinouts

IMBA-H110 ATX Motherboard

3.2.29 TPM Connector

- CN Label:** TPM1
- CN Type:** 20-pin header, p=2.54 mm
- CN Location:** See **Figure 3-30**
- CN Pinouts:** See **Table 3-27**

The TPM connector connects to a TPM module.

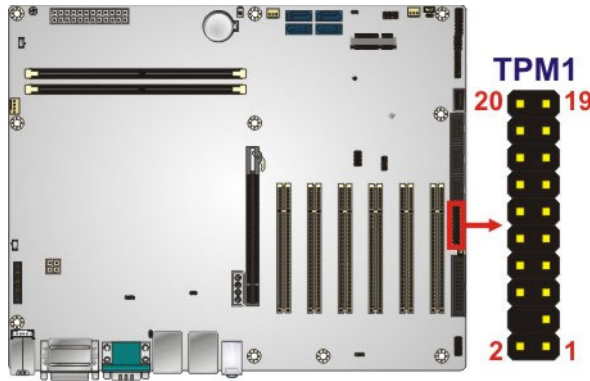

Figure 3-30: TPM Connector Location

Pin	Description	Pin	Description
1	LCLK	2	GND
3	LFRAME#	4	KEY
5	LRERST#	6	+5V
7	LAD3	8	LAD2
9	+3.3V	10	LAD1
11	LAD0	12	GND
13	SCL	14	SDA
15	SB3V	16	SERIRQ
17	GND	18	GLKRUN#
19	LPCPD#	20	LDRO#

Table 3-27: TPM Connector Pinouts

3.2.30 USB 2.0 Connector (Type A)

- CN Label:** USB2-3
- CN Type:** USB Type A
- CN Location:** See **Figure 3-31**
- CN Pinouts:** See **Table 3-28**

The USB Type A connector connects to a USB 2.0/1.1 device.

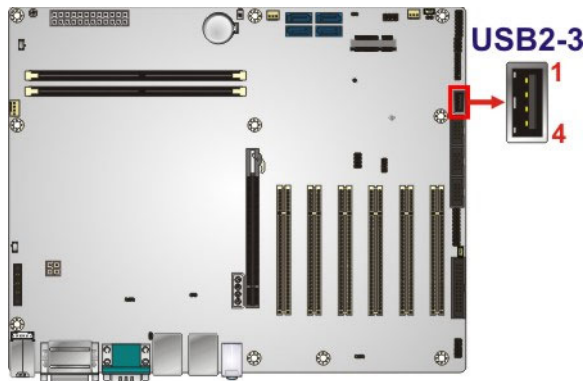

Figure 3-31: USB 2.0 Connector (Type A) Pinout Location

Pin	Description
1	VCC
2	DATA-
3	DATA+
4	GROUND

Table 3-28: USB 2.0 Connector (Type A) Pinouts

IMBA-H110 ATX Motherboard

3.2.31 USB 2.0 Connector

- CN Label:** USB1
- CN Type:** 8-pin header, p=2.54 mm
- CN Location:** See **Figure 3-32**
- CN Pinouts:** See **Table 3-29**

The USB 2.0 connector connects to USB 2.0 devices. Each pin header provides two USB 2.0 ports.

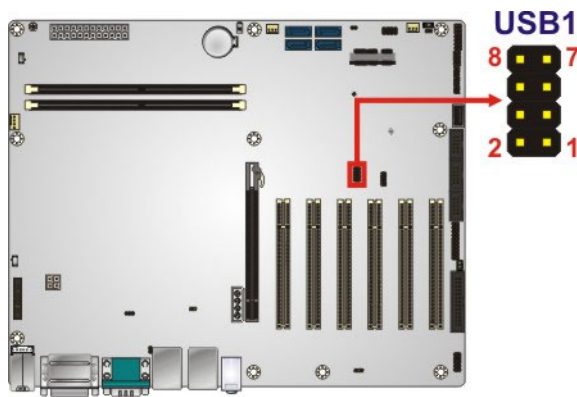

Figure 3-32: USB 2.0 Connector Pinout Locations

Pin	Description	Pin	Description
1	VCC	2	GND
3	USB_DATA-	4	USB_DATA+
5	USB_DATA+	6	USB_DATA-
7	GND	8	VCC

Table 3-29: USB 2.0 Connector Pinouts

3.3 External Peripheral Interface Connector Panel

The figure below shows the external peripheral interface connector (EPIC) panel. The EPIC panel consists of the following:

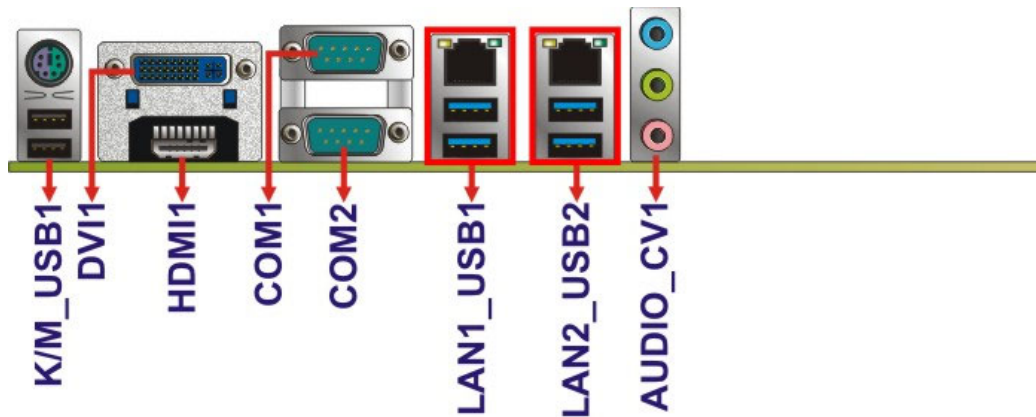

Figure 3-33: External Peripheral Interface Connector

3.3.1 Audio Connector

CN Label:	AUDIO_CV1
CN Type:	Audio jack
CN Location:	See Figure 3-33

The audio jacks connect to external audio devices.

- **Line In port (Light Blue):** Connects a CD-ROM, DVD player, or other audio devices.
- **Line Out port (Lime):** Connects to a headphone or a speaker. With multi-channel configurations, this port can also connect to front speakers.
- **Microphone (Pink):** Connects a microphone.

IMBA-H110 ATX Motherboard

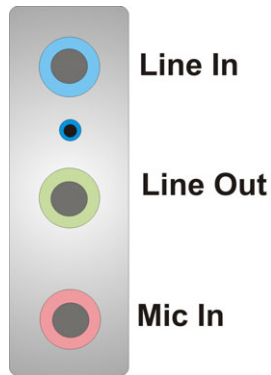

Figure 3-34: Audio Connector

3.3.2 DVI-I and HDMI Connectors

- CN Label:** DVI1, HDMI1
- CN Type:** 24-pin DVI-I, HDMI 1.4
- CN Location:** See **Figure 3-33**
- CN Pinouts:** See **Table 3-30** and **Table 3-31**

The Digital Visual Interface (DVI) connector connects to a high-speed, high-resolution digital display. The DVI-I connector supports both digital and analog signals.



NOTE:

To connect a CRT monitor to the DVI-I connector, the user has to set the DVI/CRT selection switch to CRT position. Please refer to **Section 4.8.3** for detailed information.

Pin	Description	Pin	Description
1	DVI_DATA2#	2	DVI_DATA2
3	GND	4	NC
5	NC	6	DDC CLK
7	DDC DATA	8	VSYNC
9	DVI_DATA1#	10	DVI_DATA1
11	GND	12	NC

Pin	Description	Pin	Description
13	NC	14	VCC5V
15	GND	16	HPDET
17	DVI_DATA0#	18	DVI_DATA0
19	GND	20	NC
21	NC	22	GND
23	DVI_CLK	24	DVI_CLK#
C1	RED	C2	GREEN
C3	BLUE	C4	HSYNC
C5	GND		

Table 3-30: DVI-I Connector Pinouts

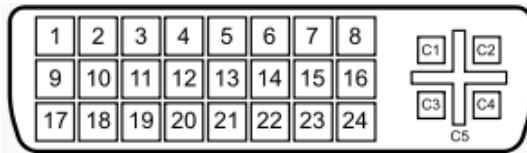

Figure 3-35: DVI-I Connector

The HDMI connector connects to a display device with HDMI interface.

Pin	Description	Pin	Description
1	HDMI_DATA2	13	NC
2	GND	14	NC
3	HDMI_DATA2#	15	HDMI_SCL
4	HDMI_DATA1	16	HDMI_SDA
5	GND	17	GND
6	HDMI_DATA1#	18	+5V
7	HDMI_DATA0	19	HDMI_HPD
8	GND	20	HDMI_GND
9	HDMI_DATA0#	21	HDMI_GND
10	HDMI_CLK	22	HDMI_GND
11	GND	23	HDMI_GND
12	HDMI_CLK#		

Table 3-31: HDMI Connector Pinouts

IMBA-H110 ATX Motherboard

3.3.3 Ethernet and USB 3.0 Connectors

CN Label: LAN1_USB1, LAN2_USB2

CN Type: RJ-45, USB 3.0

CN Location: See **Figure 3-33**

CN Pinouts: See **Table 3-32** and **Table 3-33**

There are four external USB 3.0 connectors on the IMBA-H110.

Pin	Description	Pin	Description
1	VCC	10	VCC
2	USB_DATA-	11	USB_DATA-
3	USB_DATA+	12	USB_DATA+
4	GND	13	GND
5	USB3_RX-	14	USB3_RX-
6	USB3_RX+	15	USB3_RX+
7	GND	16	GND
8	USB3_TX-	17	USB3_TX-
9	USB3_TX+	18	USB3_TX+

Table 3-32: USB 3.0 Port Pinouts

Each LAN connector connects to a local network

Pin	Description	Pin	Description
1	LAN_MDI0P	5	LAN_MDI2P
2	LAN_MDI0N	6	LAN_MDI2N
3	LAN_MDI1P	7	LAN_MDI3P
4	LAN_MDI1N	8	LAN_MDI3N

Table 3-33: LAN Pinouts

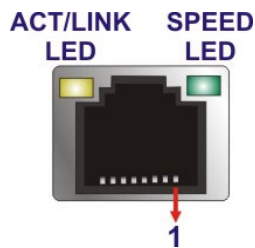

Figure 3-36: LAN Connector

3.3.4 Keyboard/Mouse and USB 2.0 Connectors

- CN Label:** K/M_USB1
- CN Type:** PS/2, USB 2.0
- CN Location:** See **Figure 3-33**
- CN Pinouts:** See **Table 3-34** and **Table 3-35**

The USB 2.0 connector can be connected to a USB 2.0/1.1 device.

Pin	Description	Pin	Description
1	VCC	5	VCC
2	USB_DATA-	6	USB_DATA-
3	USB_DATA+	7	USB_DATA+
4	GND	8	GND

Table 3-34: USB 2.0 Port Pinouts

The PS/2 port is for connecting a PS/2 mouse or keyboard.

Pin	Description
9	GND
10	Keyboard Data
11	Mouse Data
12	VCC
13	Keyboard Clock
14	Mouse Clock

Table 3-35: PS/2 Connector Pinouts

IMBA-H110 ATX Motherboard

3.3.5 Serial Port Connectors

- CN Label:** COM1 (top), COM2 (bottom)
- CN Type:** DB-9 connector
- CN Location:** See **Figure 3-33**
- CN Pinouts:** See **Table 3-36** and **Figure 3-37**

The serial port connects to a RS-232 serial communications device.

Pin	Description	Pin	Description
1	DATA CARRIER DETECT	6	DATA SET READY
2	RECEIVE DATA	7	REQUEST TO SEND
3	TRANSMIT DATA	8	CLEAR TO SEND
4	DATA TERMINAL READY	9	RING INDICATOR
5	GND		

Table 3-36: Serial Port Connector Pinouts

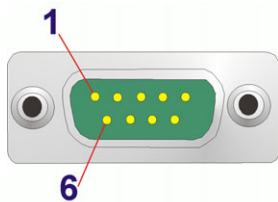

Figure 3-37: Serial Port Connector Pinouts

Chapter

4

Installation

IMBA-H110 ATX Motherboard

4.1 Anti-static Precautions



WARNING:

Failure to take ESD precautions during the installation of the IMBA-H110 may result in permanent damage to the IMBA-H110 and severe injury to the user.

Electrostatic discharge (ESD) can cause serious damage to electronic components, including the IMBA-H110. Dry climates are especially susceptible to ESD. It is therefore critical that whenever the IMBA-H110 or any other electrical component is handled, the following anti-static precautions are strictly adhered to.

- **Wear an anti-static wristband:** - Wearing a simple anti-static wristband can help to prevent ESD from damaging the board.
- **Self-grounding:**- Before handling the board touch any grounded conducting material. During the time the board is handled, frequently touch any conducting materials that are connected to the ground.
- **Use an anti-static pad:** When configuring the IMBA-H110, place it on an anti-static pad. This reduces the possibility of ESD damaging the IMBA-H110.
- **Only handle the edges of the PCB:-:** When handling the PCB, hold the PCB by the edges.

4.2 Installation Considerations



NOTE:

The following installation notices and installation considerations should be read and understood before installation. All installation notices must be strictly adhered to. Failing to adhere to these precautions may lead to severe damage and injury to the person performing the installation.

**WARNING:**

The installation instructions described in this manual should be carefully followed in order to prevent damage to the components and injury to the user.

Before and during the installation please **DO** the following:

- Read the user manual:
 - The user manual provides a complete description of the IMBA-H110 installation instructions and configuration options.
- Wear an electrostatic discharge cuff (ESD):
 - Electronic components are easily damaged by ESD. Wearing an ESD cuff removes ESD from the body and helps prevent ESD damage.
- Place the IMBA-H110 on an anti-static pad:
 - When installing or configuring the motherboard, place it on an anti-static pad. This helps to prevent potential ESD damage.
- Turn all power to the IMBA-H110 off:
 - When working with the IMBA-H110, make sure that it is disconnected from all power supplies and that no electricity is being fed into the system.

Before and during the installation of the IMBA-H110, **DO NOT**:

- Remove any of the stickers on the PCB board. These stickers are required for warranty validation.
- Use the product before verifying all the cables and power connectors are properly connected.
- Allow screws to come in contact with the PCB circuit, connector pins, or its components.

4.3 Socket LGA1151 CPU Installation

**WARNING:**

CPUs are expensive and sensitive components. When installing the CPU please be careful not to damage it in anyway. Make sure the CPU is installed properly and ensure the correct cooling kit is properly installed.

DO NOT touch the pins at the bottom of the CPU. When handling the CPU, only hold it on the sides.

To install the CPU, follow the steps below.

Step 1: **Disengage the load lever** by pressing the lever down and slightly outward to clear the retention tab. Fully open the lever. See **Figure 4-1**.

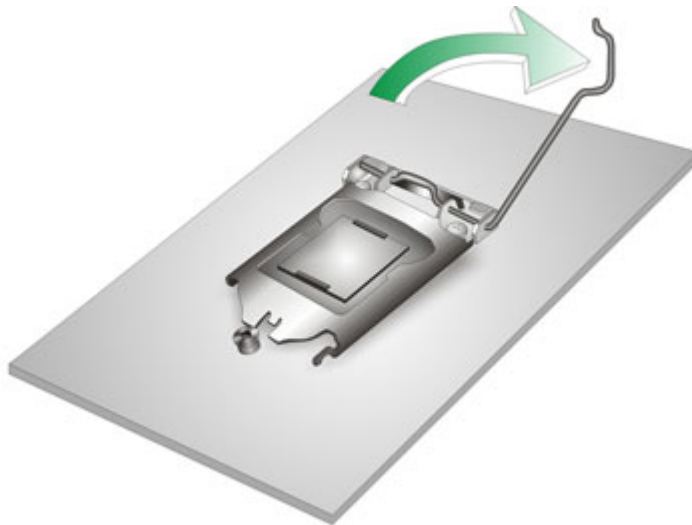

Figure 4-1: Disengage the CPU Socket Load Lever

Step 2: **Open the socket and remove the protective cover.** The black protective cover can be removed by pulling up on the tab labeled "Remove". See **Figure 4-2**.

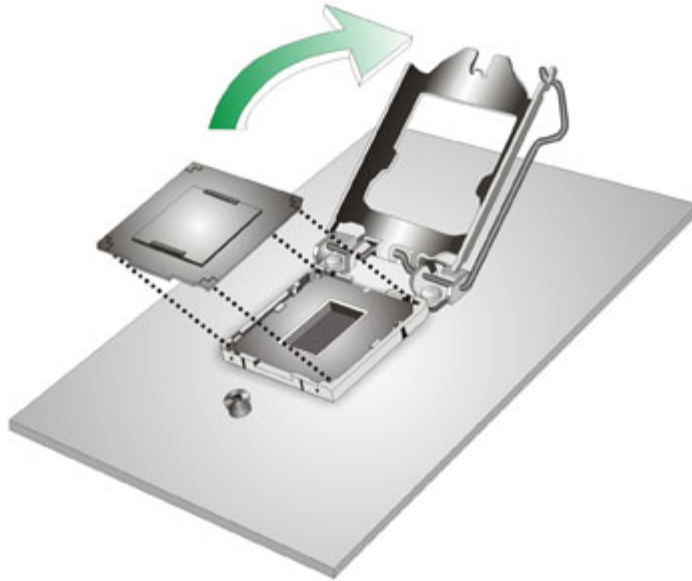

Figure 4-2: Remove Protective Cover

- Step 3: Inspect the CPU socket.** Make sure there are no bent pins and make sure the socket contacts are free of foreign material. If any debris is found, remove it with compressed air.
- Step 4: Orientate the CPU properly.** The contact array should be facing the CPU socket.



WARNING:

DO NOT touch the pins at the bottom of the CPU. When handling the CPU, only hold it on the sides.

-
- Step 5: Correctly position the CPU.** Match the Pin 1 mark with the cut edge on the CPU socket.
- Step 6: Align the CPU pins.** Locate pin 1 and the two orientation notches on the CPU. Carefully match the two orientation notches on the CPU with the socket alignment keys.

IMBA-H110 ATX Motherboard

Step 7: Insert the CPU. Gently insert the CPU into the socket. If the CPU pins are properly aligned, the CPU should slide into the CPU socket smoothly. See **Figure 4-3**.

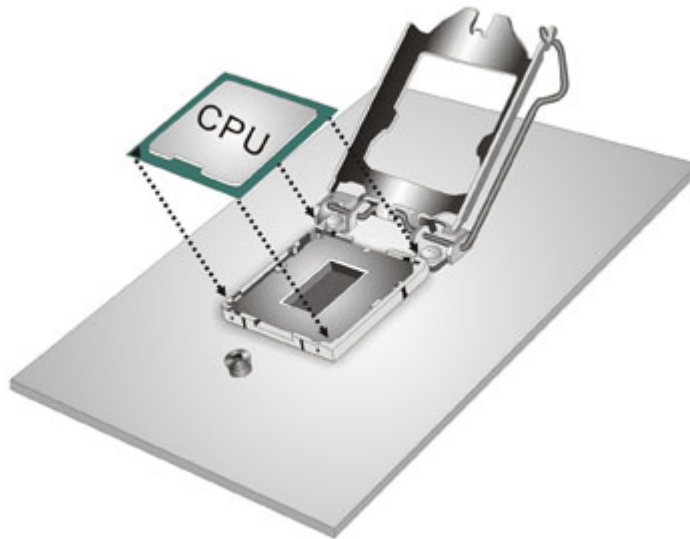

Figure 4-3: Insert the Socket LGA1151 CPU

Step 8: Close the CPU socket. Close the load plate and pull the load lever back a little to have the load plate be able to secure to the knob. Engage the load lever by pushing it back to its original position (**Figure 4-4**). There will be some resistance, but will not require extreme pressure.

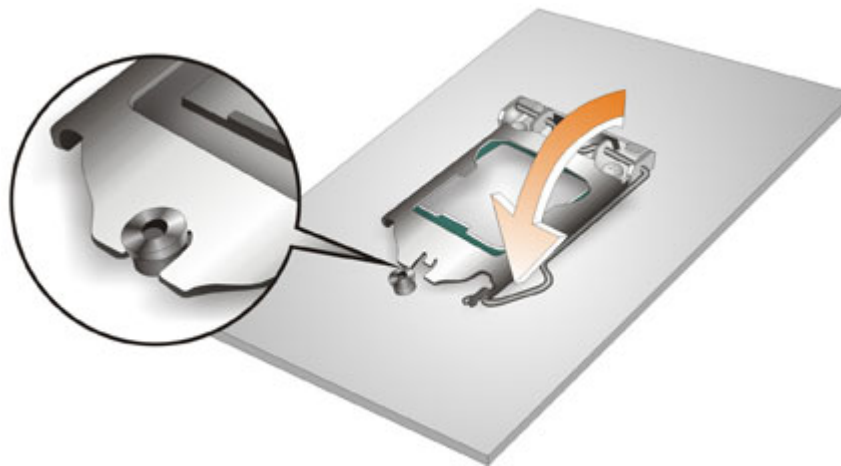

Figure 4-4: Close the Socket LGA1151

Step 9: Connect the 12 V power to the board. Connect the 12 V power from the power supply to the board.

4.4 Socket LGA1151 Cooling Kit Installation



WARNING:

DO NOT attempt to install a push-pin cooling fan.

The pre-installed support bracket prevents the board from bending and is **ONLY** compatible with captive screw type cooling fans.

The cooling kit can be bought from IEI. The cooling kit has a heat sink and fan.



WARNING:

Do not wipe off (accidentally or otherwise) the pre-sprayed layer of thermal paste on the bottom of the heat sink. The thermal paste between the CPU and the heat sink is important for optimum heat dissipation.

To install the cooling kit, follow the instructions below.

Step 1: A cooling kit bracket is pre-installed on the rear of the motherboard. See **Figure 4-5**.

IMBA-H110 ATX Motherboard

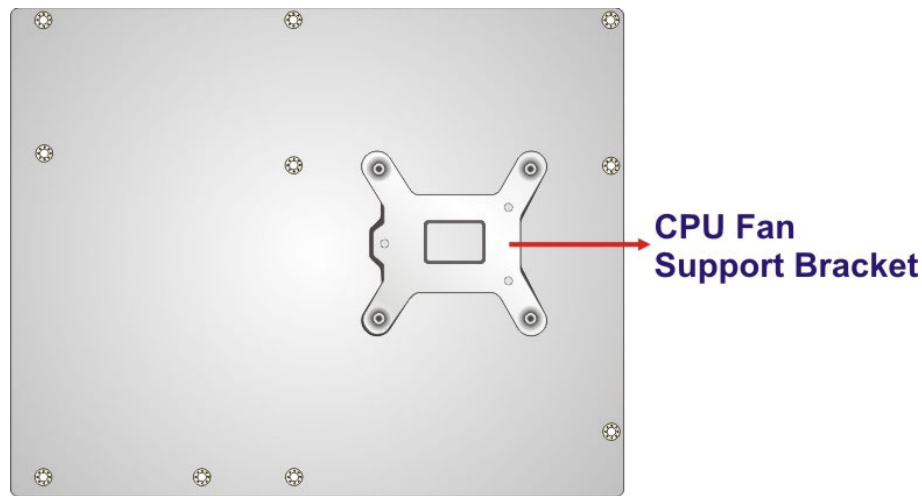

Figure 4-5: Cooling Kit Support Bracket

- Step 2:** Place the cooling kit onto the socket LGA1151 CPU. Make sure the CPU cable can be properly routed when the cooling kit is installed.
- Step 3:** Mount the cooling kit. Gently place the cooling kit on top of the CPU. Make sure the four threaded screws on the corners of the cooling kit properly pass through the holes of the cooling kit bracket.
- Step 4:** Tighten the screws. Use a screwdriver to tighten the four screws. In a diagonal pattern, tighten each screw a few turns then move to the next one, until they are all secured. Do not overtighten the screws.
- Step 5:** Connect the fan cable. Connect the cooling kit fan cable to the CPU fan connector on the IMBA-H110. Carefully route the cable and avoid heat generating chips and fan blades.

4.5 DIMM Installation

To install a DIMM, please follow the steps below and refer to **Figure 4-6**.

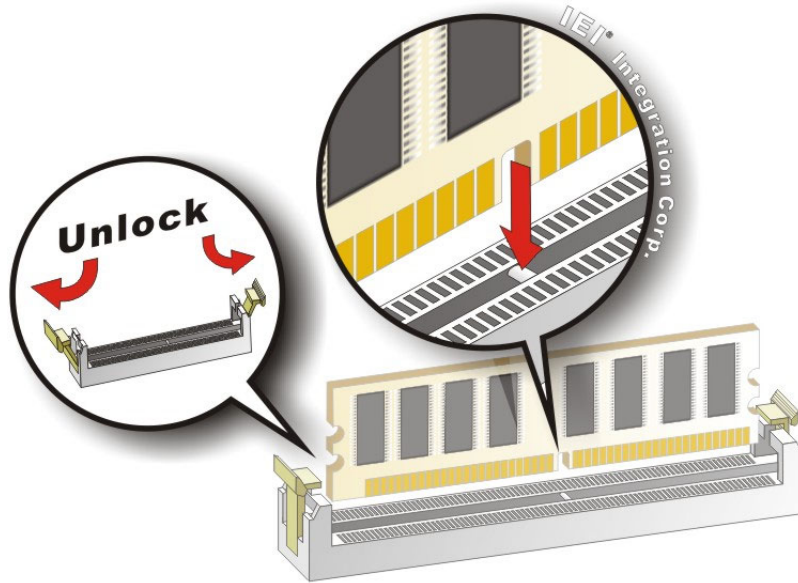

Figure 4-6: DIMM Installation

- Step 1:** **Open the DIMM socket handles.** Open the two handles outwards as far as they can. See **Figure 4-6**.
- Step 2:** **Align the DIMM with the socket.** Align the DIMM so the notch on the memory lines up with the notch on the memory socket. See **Figure 4-6**.
- Step 3:** **Insert the DIMM.** Once aligned, press down until the DIMM is properly seated. Clip the two handles into place. See **Figure 4-6**.
- Step 4:** To remove a DIMM, push both handles outward. The memory module is ejected by a mechanism in the socket.

IMBA-H110 ATX Motherboard

4.6 Full-size PCIe Mini Card Installation

The PCIe Mini card slot allows installation of either a full-size or half-size PCIe Mini card. To install a full-size PCIe Mini card, please follow the steps below.

Step 1: Locate the PCIe Mini card slot. See Chapter 3.

Step 2: Remove the retention screw. Remove the retention screw as shown in Figure 4-7.

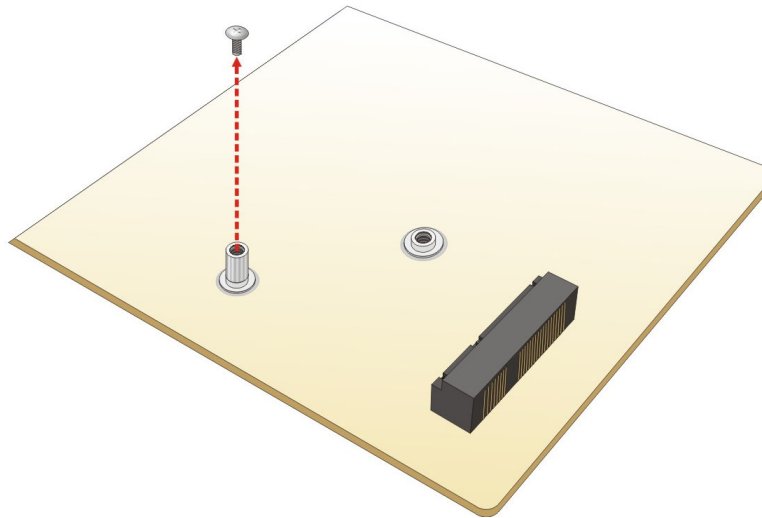

Figure 4-7: Removing the Retention Screw

Step 3: Insert into the socket at an angle. Line up the notch on the card with the notch on the slot. Slide the PCIe Mini card into the socket at an angle of about 20° (Figure 4-8).

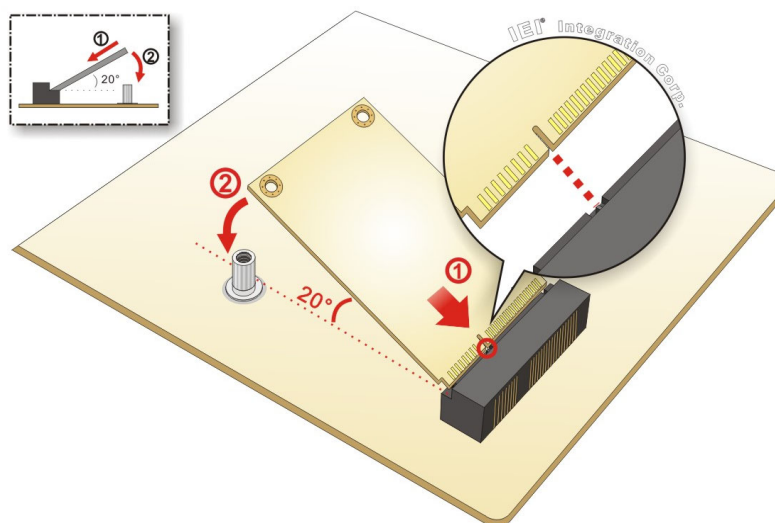

Figure 4-8: Inserting the Full-size PCIe Mini Card into the Slot at an Angle

Step 4: **Secure the full-size PCIe Mini card.** Secure the full-size PCIe Mini card with the retention screw previously removed (**Figure 4-9**).

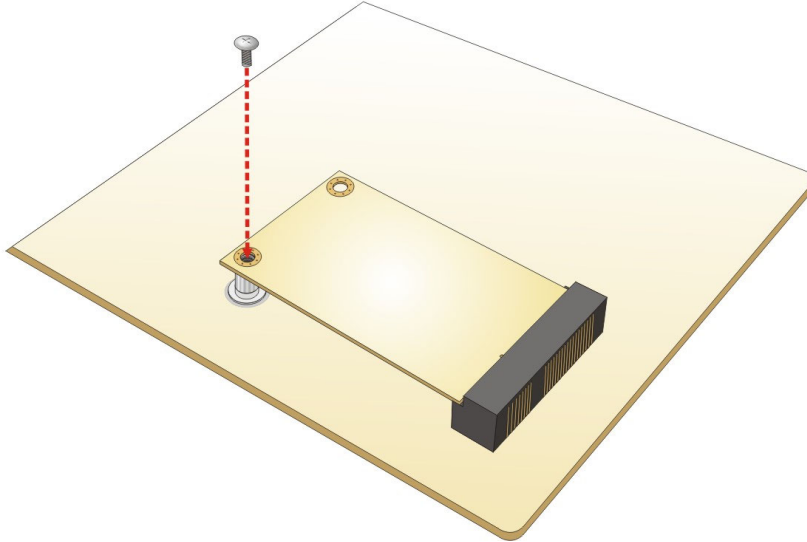

Figure 4-9: Securing the Full-size PCIe Mini Card

4.7 Half-size PCIe Mini Card Installation

The PCIe Mini card slot allows installation of either a full-size or half-size PCIe Mini card. To install a half-size PCIe Mini card, please follow the steps below.

Step 1: **Locate the PCIe Mini card slot.** See **Chapter 3**.

Step 2: **Install the standoff to the screw hole for the half-size PCIe Mini card.** Install the supplied standoff to the screw hole for the half-size PCIe Mini card (**Figure 4-10**).

IMBA-H110 ATX Motherboard

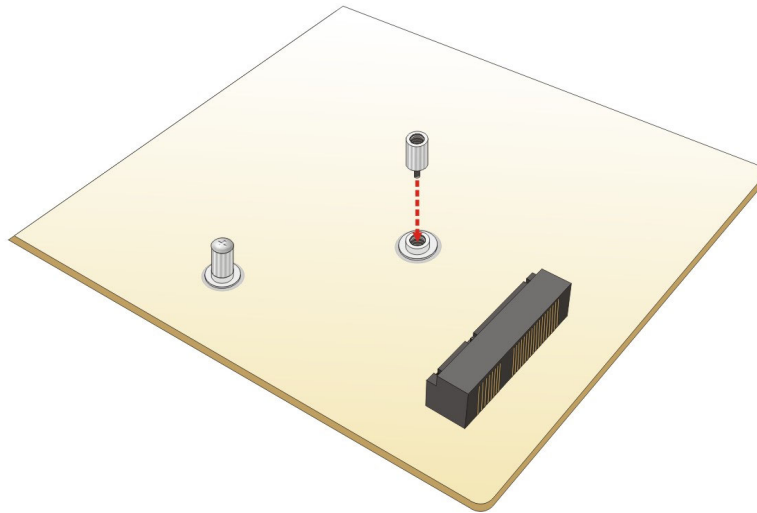

Figure 4-10: Installing the Standoff

Step 3: Insert into the socket at an angle. Line up the notch on the card with the notch on the slot. Slide the PCIe Mini card into the slot at an angle of about 20° (Figure 4-11).

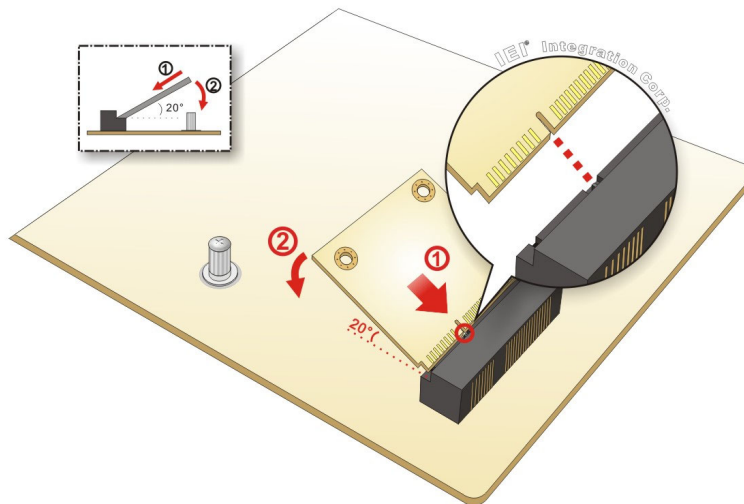

Figure 4-11: Inserting the Half-size PCIe Mini Card into the Slot at an Angle

Step 4: Secure the half-size PCIe Mini card. Secure the half-size PCIe Mini card with the supplied retention screw (Figure 4-12).

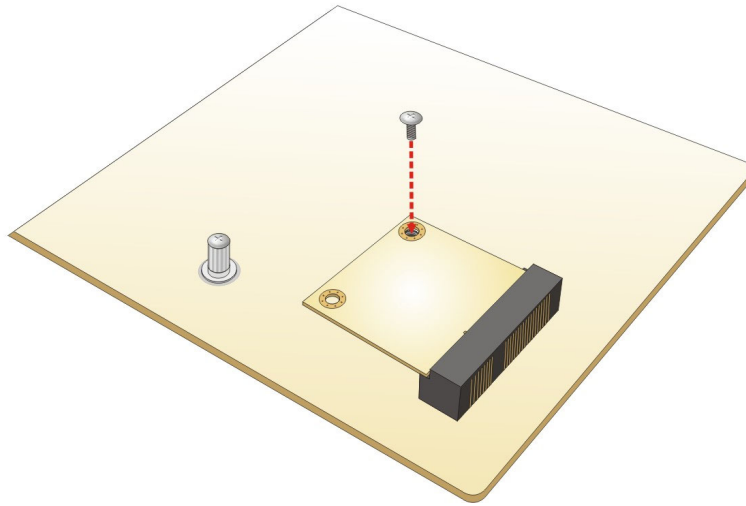

Figure 4-12: Securing the Half-size PCIe Mini Card

4.8 System Configuration

The system configuration should be performed before installation.

4.8.1 AT/ATX Power Mode Setting

The AT and ATX power mode selection is made through the AT/ATX power mode switch which is shown in **Figure 4-13**.

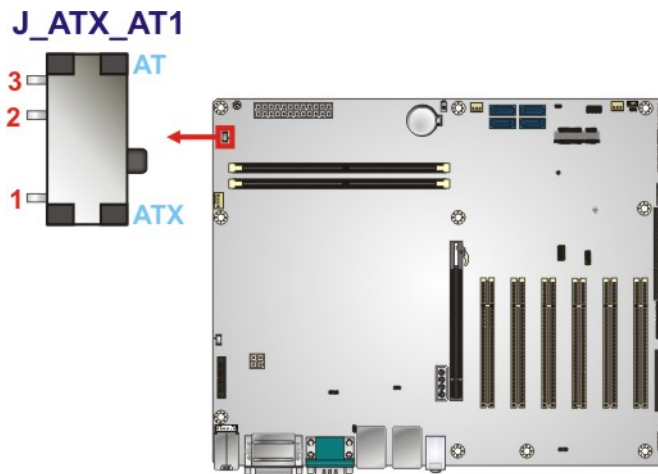

Figure 4-13: AT/ATX Power Mode Switch Location

IMBA-H110 ATX Motherboard

Setting	Description
1-2	ATX power mode (default)
2-3	AT power mode

Table 4-1: AT/ATX Power Mode Switch Settings

4.8.2 Clear CMOS Button

To reset the BIOS, remove the on-board battery and press the clear CMOS button for three seconds or more. The clear CMOS button location is shown in **Figure 4-14**.

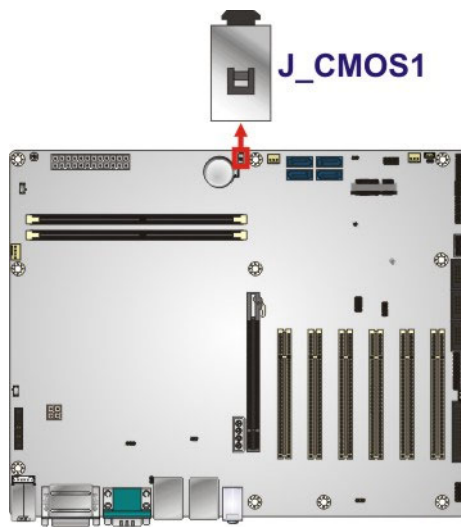

Figure 4-14: Clear CMOS Button Location

4.8.3 DVI/CRT Selection Switch

The DVI-I connector on the rear panel supports both digital and analog signals. To connect a CRT monitor to the DVI-I connector, the user has to set the DVI/CRT selection switch to CRT position. Refer to **Figure 4-15** and **Table 4-2** for the switch location and settings.

Setting	Description
1-2	DVI monitor (Default)
2-3	CRT monitor

Table 4-2: DVI/CRT Selection Switch Settings

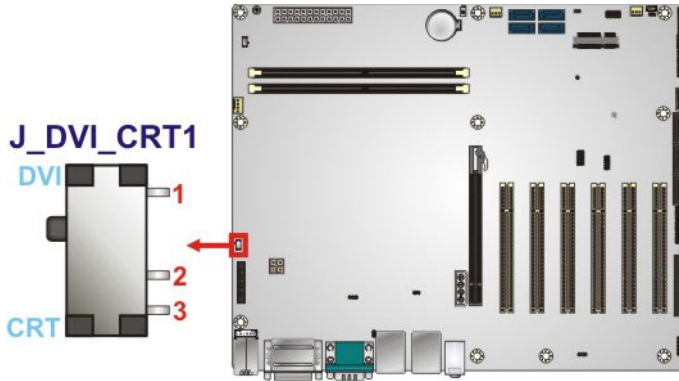

Figure 4-15: DVI/CRT Selection Switch Location

4.8.4 Flash Descriptor Security Override

The Flash Descriptor Security Override jumper (J_FLASH1) allows to enable or disable the ME firmware update. Refer to **Figure 4-16** and **Table 4-3** for the jumper location and settings.

Setting	Description
Short 1-2	Disabled (default)
Short 2-3	Enabled

Table 4-3: Flash Descriptor Security Override Jumper Settings

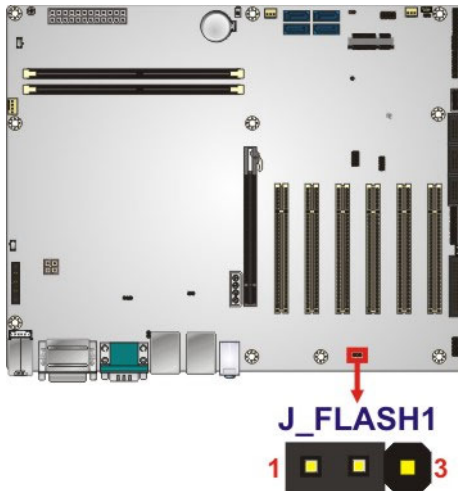

Figure 4-16: Flash Descriptor Security Override Jumper Location

To update the ME firmware, please follow the steps below.

IMBA-H110 ATX Motherboard

- Step 1:** Before turning on the system power, short pin 2-3 of the Flash Descriptor Security Override jumper.
- Step 2:** Update the BIOS and ME firmware, and then turn off the system power.
- Step 3:** Remove the metal clip on the Flash Descriptor Security Override jumper or return to its default setting (short pin 1-2).
- Step 4:** Restart the system. The system will reboot 2 ~ 3 times to complete the ME firmware update.

4.8.5 mSATA Setup Jumper

The mSATA setup jumper specifies whether to automatically detect the mSATA device installed in the PCIe Mini slot. If the user shorts the mSATA setup jumper to force the system to enable mSATA device, the S_ATA4 connector will be disabled.

Setting	Description
Open	Automatically detect mSATA device (Default)
Short 1-2	Force to enable mSATA device (The S_ATA4 connector will be disabled)

Table 4-4: mSATA Setup Jumper Settings

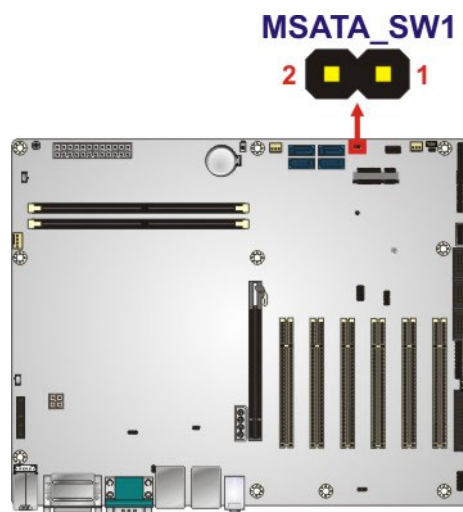

Figure 4-17: mSATA Setup Jumper Location

4.8.6 USB Power Selection

The USB power selection is made through the BIOS menu in “Chipset → PCH-IO Configuration”. Use the **USB Power SW1** and the **USB Power SW2** BIOS options to configure the correspondent USB ports (see **Table 4-5**) and refer to **Table 4-6** to select the USB power source.

BIOS Options	Configured USB Ports
USB Power SW1	LAN1_USB1 (external USB 3.0 ports) LAN2_USB2 (external USB 3.0 ports) K/M_USB1 (external USB 2.0 ports)
USB Power SW2	USB1 (internal USB 2.0 ports) USB2-3 (internal USB 2.0 port, Type A)

Table 4-5: BIOS Options and Configured USB Ports

Options	Description
+5V DUAL	+5V dual (default)
+5V	+5V

Table 4-6: USB Power Source Setup

Please refer to **Section 5.4.2** for detailed information.

4.9 Internal Peripheral Device Connections

This section outlines the installation of peripheral devices to the onboard connectors.

4.9.1 SATA Drive Connection

The IMBA-H110 is shipped with two SATA drive cables. To connect the SATA drives to the connectors, please follow the steps below.

Step 1: Locate the connectors. The locations of the SATA drive connectors are shown in **Chapter 3**.

Step 2: Insert the cable connector. Insert the cable connector into the on-board SATA drive connector until it clips into place. See **Figure 4-18**.

IMBA-H110 ATX Motherboard

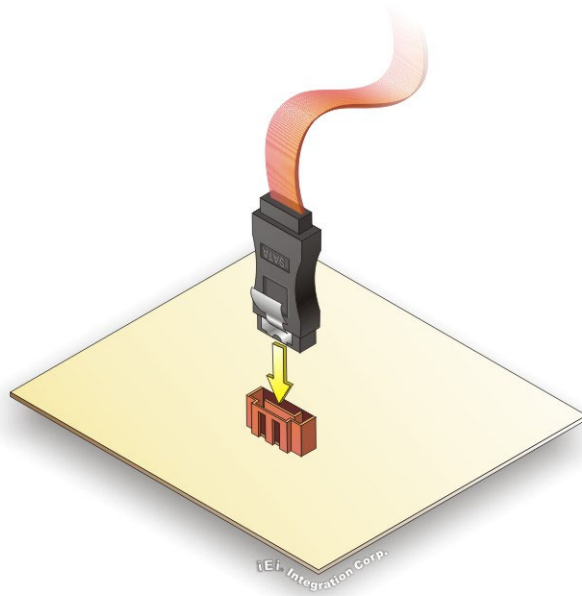

Figure 4-18: SATA Drive Cable Connection

- Step 3:** **Connect the cable to the SATA disk.** Connect the connector on the other end of the cable to the connector at the back of the SATA drive. See **Figure 4-19**.
- Step 4:** **Connect the SATA power cable.** Connect the SATA power connector to the back of the SATA drive. See **Figure 4-19**.

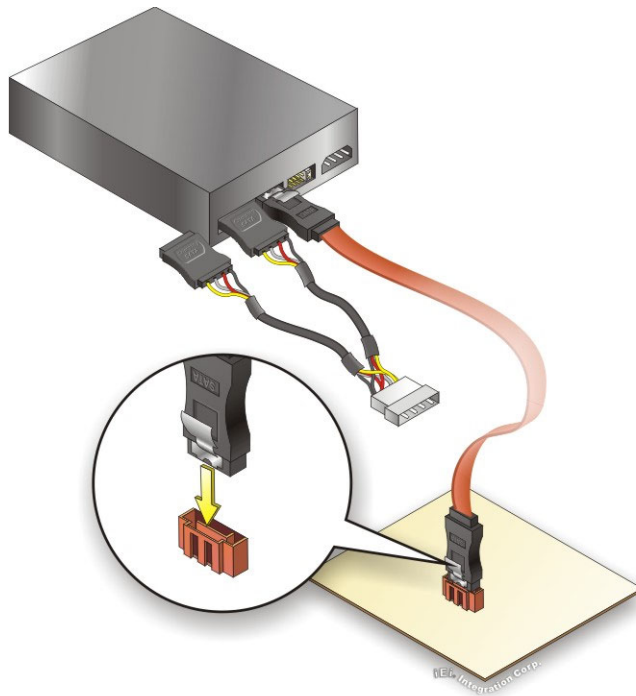

Figure 4-19: SATA Power Drive Connection

The SATA power cable can be bought from IEI. See Optional Items in Section 2.4.

4.10 Adding USB 3.0 Drivers to a Windows 7 Installation Image

The Windows 7 installation media does not include native driver support for USB 3.0. In order to use the USB keyboard or mouse connected to a USB 3.0 port during OS installation, the user has to update the Windows 7 installation image so that it contains USB 3.0 drivers. Please follow the instructions below to complete the task.

Step 1: Prepare a USB flash drive installer.

On a working computer, use your Windows 7 DVD or ISO image to create a bootable USB flash drive.

Step 2: Download the Windows 7 USB 3.0 Creator Utility from:

<https://downloadcenter.intel.com/download/25476/Windows-7-USB-3-0-Creator-Utility>.

IMBA-H110 ATX Motherboard

Step 3: Extract the downloaded file to a temporary folder on a computer where the user has logged in as the administrator.



NOTE:

The OS version of the computer can be Windows 7, Windows 8.1 or Windows 10.

Step 4: Connect the USB drive containing the Windows 7 installation image to the computer.

Step 5: Right click on **Installer_Creator.exe** from the extracted files and select **Run as administrator**.

Step 6: The Windows 7 USB 3.0 Creator Utility screen appears (**Figure 4-20**). Click  to browse to the root of the USB drive containing the Windows 7 image.

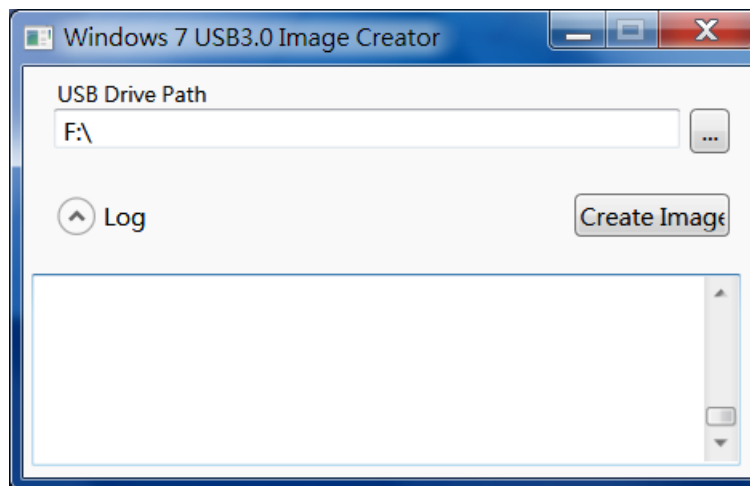

Figure 4-20: Windows 7 USB 3.0 Creator Utility

Step 7: Click **Create Image** to start the update process.

Step 8: Wait for the process to finish. It may take up to 15 minutes.

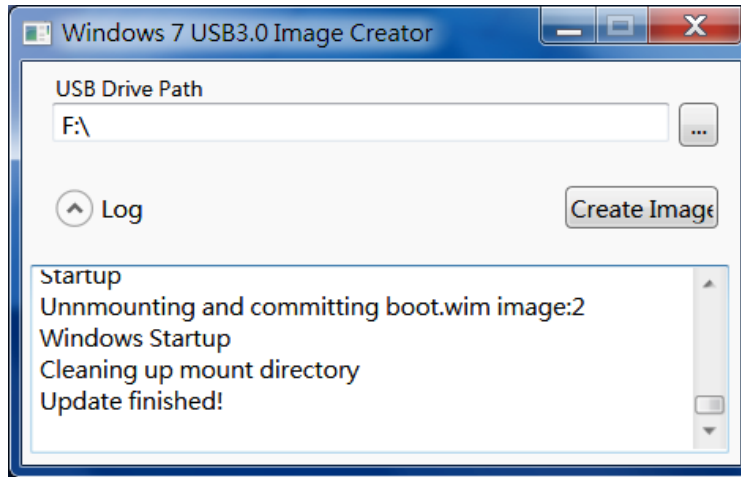

Figure 4-21: Update Process is Complete

Step 9: Now the user can proceed with the Windows 7 installation using the updated installer.

4.11 Driver Installation

All the drivers for the IMBA-H110 are on the CD that came with the system. To install the drivers, please follow the steps below.



NOTE:

The content of the CD may vary throughout the life cycle of the product and is subject to change without prior notice. Visit the IEI website or contact technical support for the latest updates.

Step 1: Insert the CD into a CD drive connected to the system.



NOTE:

If the installation program doesn't start automatically:
Click "Start->My Computer->CD Drive->autorun.exe"

IMBA-H110 ATX Motherboard

- Step 2:** The driver main menu appears. Click IMBA-H110.
- Step 3:** A new screen with a list of available drivers appears.
- Step 4:** Install all of the necessary drivers in the menu.

Chapter

5

BIOS

IMBA-H110 ATX Motherboard

5.1 Introduction

The BIOS is programmed onto the BIOS chip. The BIOS setup program allows changes to certain system settings. This chapter outlines the options that can be changed.



NOTE:

Some of the BIOS options may vary throughout the life cycle of the product and are subject to change without prior notice.

5.1.1 Starting Setup

The UEFI BIOS is activated when the computer is turned on. The setup program can be activated in one of two ways.

1. Press the **DEL** or **F2** key as soon as the system is turned on or
2. Press the **DEL** or **F2** key when the “**Press DEL or F2 to enter SETUP**” message appears on the screen.

If the message disappears before the **DEL** or **F2** key is pressed, restart the computer and try again.

5.1.2 Using Setup

Use the arrow keys to highlight items, press **ENTER** to select, use the PageUp and PageDown keys to change entries, press **F1** for help and press **ESC** to quit. Navigation keys are shown in the following table.

Key	Function
Up arrow	Move to previous item
Down arrow	Move to next item
Left arrow	Move to the item on the left hand side
Right arrow	Move to the item on the right hand side
+	Increase the numeric value or make changes
-	Decrease the numeric value or make changes

Key	Function
Page Up	Move to the previous page
Page Dn	Move to the next page
Esc	Main Menu – Quit and not save changes into CMOS Status Page Setup Menu and Option Page Setup Menu -- Exit current page and return to Main Menu
F1	General help, only for Status Page Setup Menu and Option Page Setup Menu
F2	Load previous values
F3	Load optimized defaults
F4	Save changes and Exit BIOS

Table 5-1: BIOS Navigation Keys

5.1.3 Getting Help

When **F1** is pressed, a small help window describing the appropriate keys to use and the possible selections for the highlighted item appears. To exit the Help Window, press **Esc**.

5.1.4 Unable to Reboot after Configuration Changes

If the computer cannot boot after changes to the system configuration is made, CMOS defaults. Use the clear CMOS button described in **Chapter 4**.

5.1.5 BIOS Menu Bar

The **menu bar** on top of the BIOS screen has the following main items:

- Main – Changes the basic system configuration.
- Advanced – Changes the advanced system settings.
- Chipset – Changes the chipset settings.
- Boot – Changes the system boot configuration.
- Security – Sets User and Supervisor Passwords.
- Save & Exit – Selects exit options and loads default settings

The following sections completely describe the configuration options found in the menu items at the top of the BIOS screen and listed above.

IMBA-H110 ATX Motherboard

5.2 Main

The **Main** BIOS menu (**BIOS Menu 1**) appears when the **BIOS Setup** program is entered.

The **Main** menu gives an overview of the basic system information.

Aptio Setup Utility - Copyright (C) 2016 American Megatrends, Inc.					
Main	Advanced	Chipset	Security	Boot	Save & Exit
BIOS Information					Set the Date. Use Tab to switch between Date elements.
BIOS Vendor			American Megatrends		
Core Version			5.11		
Compliance			UEFI 2.4; PI 1.3		
Project Version			B383AR12.ROM		
Build Date and Time			09/01/2016 14:20:17		
iWDD Vendor			iEi		
iWDD Version			B388ER11.bin		
Processor Information					
Name			SkyLake DT		
Brand String			Intel(R) Core(TM) i5-6500TE CPU @ 2.30GHz		
Frequency			2300 MHz		
Processor ID			506E3		
Stepping			R0/S0/N0		
Number of Processors			4Core(s) / 4Thread(s)		-----
Microcode Revision			7C		→←: Select Screen
GT Info			GT2		↑ ↓: Select Item
IGFX VBIOS Version			1036		Enter: Select
Memory RC Version			1.8.0.1		+/-: Change Opt.
Total Memory			4096 MB		F1: General Help
Memory Frequency			2133 MHz		F2: Previous Values
PCH Information					F3: Optimized Defaults
Name			SKL PCH-H		F4: Save & Exit
PCH SKU			PCH-H Desktop H110 SKU		ESC: Exit
Stepping			31/D1		
LAN PHY Revision			B2		
ME FW Version			11.0.0.1205		
ME Firmware SKU			Consumer SKU		
SPI Clock Frequency					
DOFR Support			Unsupported		
Read Status Clock Frequency			17 MHz		
Write Status Clock Frequency			48 MHz		
Fast Read Status Clock Frequency			48 MHz		
Access Level			Administrator		
System Date			[Thu 10/27/2016]		
System Time			[15:10:27]		
Version 2.17.1255. Copyright (C) 2016 American Megatrends, Inc.					

BIOS Menu 1: Main

The **Main** menu has two user configurable fields:

→ **System Date [xx/xx/xx]**

Use the **System Date** option to set the system date. Manually enter the day, month and year.

→ **System Time [xx:xx:xx]**

Use the **System Time** option to set the system time. Manually enter the hours, minutes and seconds.

5.3 Advanced

Use the **Advanced** menu (**BIOS Menu 2**) to configure the CPU and peripheral devices through the following sub-menus:



WARNING!

Setting the wrong values in the sections below may cause the system to malfunction. Make sure that the settings made are compatible with the hardware.

```

Aptio Setup Utility - Copyright (C) 2016 American Megatrends, Inc.
Main  Advanced  Chipset  Security  Boot  Save & Exit  Server Mgmt
-----
> Trusted Computing
> ACPI Settings
> Super IO Configuration
> iWDD H/M Monitor
> RTC Wake Settings
> Serial Port Console Redirection
> CPU Configuration
> SATA Configuration
> NVMe Configuration
> USB Configuration
> iEi Feature

Trusted Computing
Settings

-----
→←: Select Screen
↑ ↓: Select Item
Enter: Select
+/-: Change Opt.
F1: General Help
F2: Previous Values
F3: Optimized Defaults
F4: Save & Exit
ESC: Exit

Version 2.17.1255. Copyright (C) 2016 American Megatrends, Inc.
    
```

BIOS Menu 2: Advanced

IMBA-H110 ATX Motherboard

5.3.1 Trusted Computing

Use the **Trusted Computing** menu (**BIOS Menu 3**) to configure settings related to the Trusted Computing Group (TCG) Trusted Platform Module (TPM).

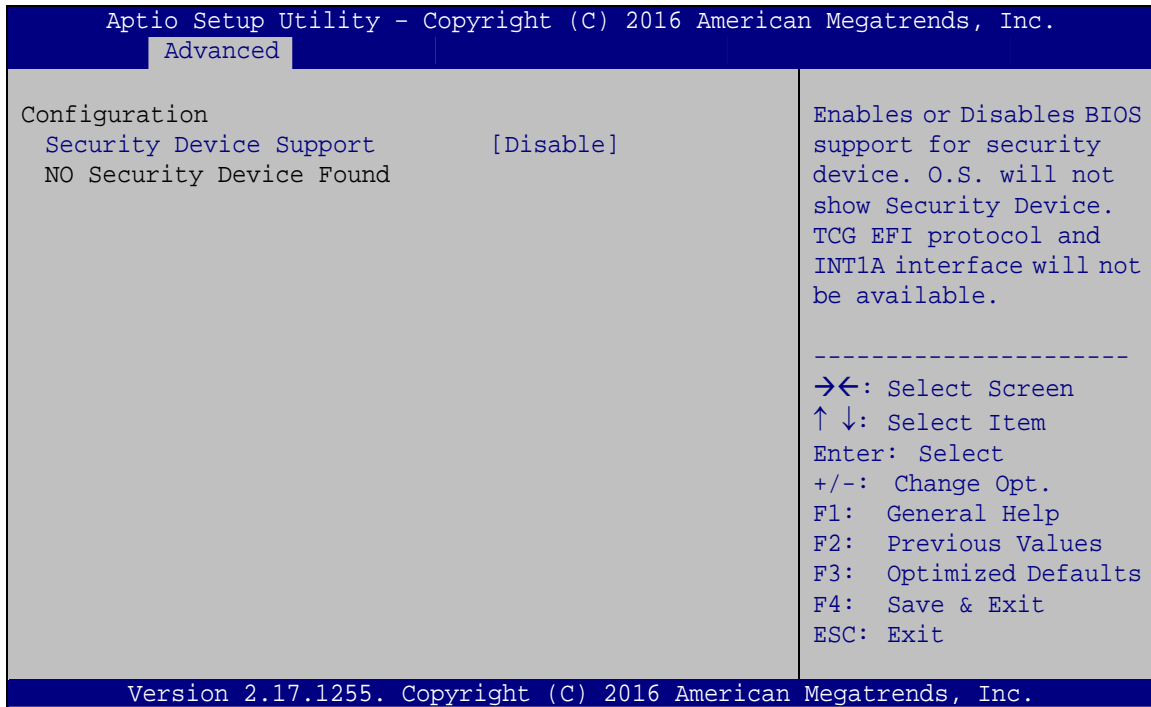

BIOS Menu 3: Trusted Computing

→ Security Device Support [Disable]

Use the **Security Device Support** option to configure support for the TPM.

- **Disable** DEFAULT TPM support is disabled.
- **Enable** TPM support is enabled.

5.3.2 ACPI Settings

The **ACPI Settings** menu (**BIOS Menu 4**) configures the Advanced Configuration and Power Interface (ACPI) options.

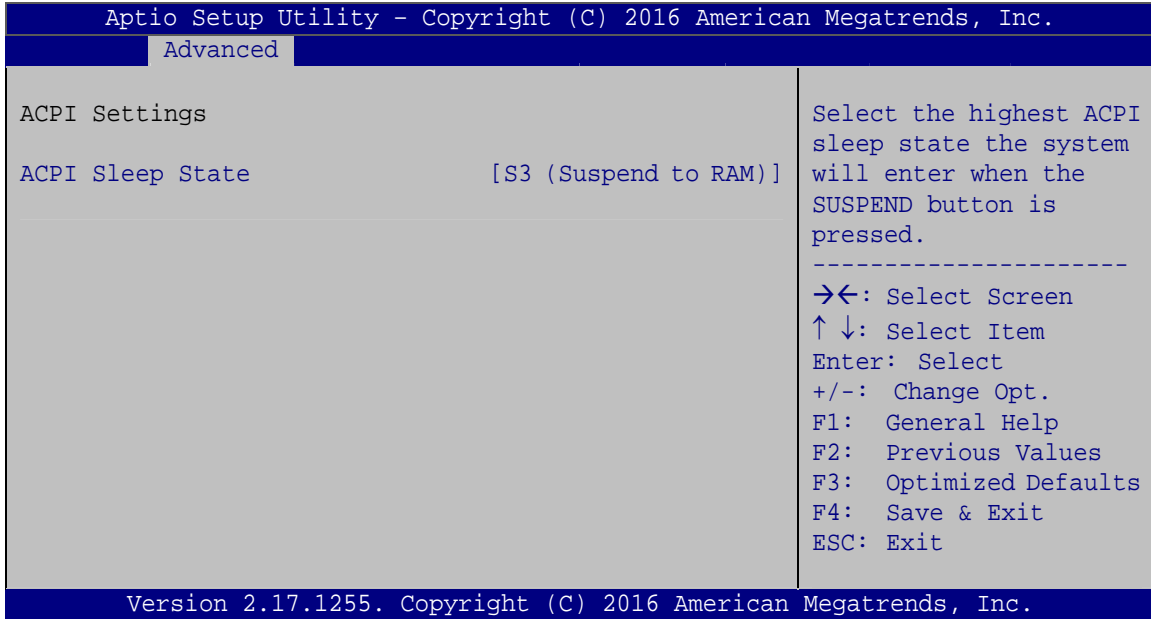

BIOS Menu 4: ACPI Configuration

→ ACPI Sleep State [S3 (Suspend to RAM)]

Use the **ACPI Sleep State** option to specify the sleep state the system enters when it is not being used.

- **S3 (Suspend to RAM)** **DEFAULT** The caches are flushed and the CPU is powered off. Power to the RAM is maintained. The computer returns slower to a working state, but more power is saved.

IMBA-H110 ATX Motherboard

5.3.3 Super IO Configuration

Use the **Super IO Configuration** menu (**BIOS Menu 5**) to set or change the configurations for the parallel ports and serial ports.

```

Aptio Setup Utility - Copyright (C) 2016 American Megatrends, Inc.
  Advanced
-----
Super IO Configuration
Super IO Chip                F81866
> Serial Port 1 Configuration
> Serial Port 2 Configuration
> Serial Port 3 Configuration
> Serial Port 4 Configuration
> Serial Port 5 Configuration
> Parallel Port Configuration

Case Open Detection          [Disabled]

Set Parameters of Serial
Port 1 (COMA)
-----
-><: Select Screen
↑↓: Select Item
Enter: Select
+/-: Change Opt.
F1: General Help
F2: Previous Values
F3: Optimized Defaults
F4: Save & Exit
ESC: Exit

Version 2.17.1255. Copyright (C) 2016 American Megatrends, Inc.
  
```

BIOS Menu 5: Super IO Configuration

➔ Case Open Detection [Disabled]

Use the **Case Open Detection** option to enable or disable the case open detection function.

- ➔ **Disabled** **DEFAULT** Disable the case open detection function
- ➔ **Enabled** Enable the case open detection function

5.3.3.1 Serial Port 1 ~ 5 Configuration

Use the **Serial Port 1 ~ 5 Configuration** menu (**BIOS Menu 6**) to configure the serial ports.

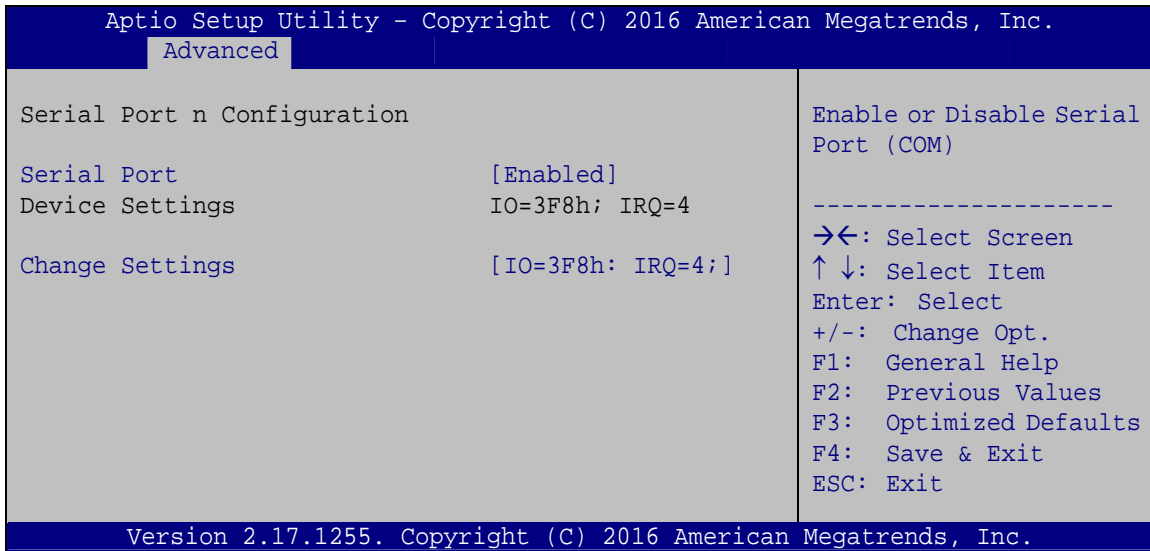

BIOS Menu 6: Serial Port 1 ~ 5 Configuration Menu

5.3.3.2 Serial Port 1 Configuration

→ Serial Port [Enabled]

Use the **Serial Port** option to enable or disable the serial port.

- **Disabled** Disable the serial port
- **Enabled** **DEFAULT** Enable the serial port

→ Change Settings [IO=3F8h; IRQ=4;]

Use the **Change Settings** option to change the serial port IO port address and interrupt address.

- **IO=3F8h; DEFAULT** Serial Port I/O port address is 3F8h and the interrupt address is IRQ4
- **IO=3F8h; IRQ=3, 4, 11** Serial Port I/O port address is 3F8h and the interrupt address is IRQ3, 4, 11
- **IO=2F8h; IRQ=3, 4, 11** Serial Port I/O port address is 2F8h and the interrupt address is IRQ3, 4, 11

IMBA-H110 ATX Motherboard

5.3.3.3 Serial Port 2 Configuration

→ Serial Port [Enabled]

Use the **Serial Port** option to enable or disable the serial port.

- **Disabled** Disable the serial port
- **Enabled** **DEFAULT** Enable the serial port

→ Change Settings [IO=2F8h; IRQ=3;]

Use the **Change Settings** option to change the serial port IO port address and interrupt address.

- **IO=2F8h; DEFAULT** Serial Port I/O port address is 2F8h and the interrupt address is IRQ3
- **IO=3F8h; IRQ=3, 4, 11** Serial Port I/O port address is 3F8h and the interrupt address is IRQ3, 4, 11
- **IO=2F8h; IRQ=3, 4, 11** Serial Port I/O port address is 2F8h and the interrupt address is IRQ3, 4, 11

5.3.3.4 Serial Port 3 Configuration

→ Serial Port [Enabled]

Use the **Serial Port** option to enable or disable the serial port.

- **Disabled** Disable the serial port
- **Enabled** **DEFAULT** Enable the serial port

→ Change Settings [IO=3E8h; IRQ=11;]

Use the **Change Settings** option to change the serial port IO port address and interrupt address.

- **IO=3E8h; DEFAULT** Serial Port I/O port address is 3E8h and the interrupt address is IRQ11

- **IO=3F8h;**
IRQ=3, 4, 11 Serial Port I/O port address is 3F8h and the interrupt address is IRQ3, 4, 11
- **IO=2F8h;**
IRQ=3, 4, 11 Serial Port I/O port address is 2F8h and the interrupt address is IRQ3, 4, 11
- **IO=3E8h;**
IRQ=3, 4, 11 Serial Port I/O port address is 3E8h and the interrupt address is IRQ3, 4, 11
- **IO=2E8h;**
IRQ=3, 4, 11 Serial Port I/O port address is 2E8h and the interrupt address is IRQ3, 4, 11
- **IO=2D0h;**
IRQ=3, 4, 11 Serial Port I/O port address is 2D0h and the interrupt address is IRQ3, 4, 11
- **IO=2E0h;**
IRQ=3, 4, 11 Serial Port I/O port address is 2E0h and the interrupt address is IRQ3, 4, 11

5.3.3.4.1 Serial Port 4 Configuration

→ Serial Port [Enabled]

Use the **Serial Port** option to enable or disable the serial port.

- **Disabled** Disable the serial port
- **Enabled** **DEFAULT** Enable the serial port

→ Change Settings [IO=2E8h; IRQ=11;]

Use the **Change Settings** option to change the serial port IO port address and interrupt address.

- **IO=2E8h;** **DEFAULT** Serial Port I/O port address is 2E8h and the interrupt address is IRQ11
- **IO=3F8h;**
IRQ=3, 4, 11 Serial Port I/O port address is 3F8h and the interrupt address is IRQ3, 4, 11
- **IO=2F8h;**
IRQ=3, 4, 11 Serial Port I/O port address is 2F8h and the interrupt address is IRQ3, 4, 11

IMBA-H110 ATX Motherboard

- ➔ **IO=3E8h;**
IRQ=3, 4, 11 Serial Port I/O port address is 3E8h and the interrupt address is IRQ3, 4, 11
- ➔ **IO=2E8h;**
IRQ=3, 4, 11 Serial Port I/O port address is 2E8h and the interrupt address is IRQ3, 4, 11
- ➔ **IO=2D0h;**
IRQ=3, 4, 11 Serial Port I/O port address is 2D0h and the interrupt address is IRQ3, 4, 11
- ➔ **IO=2E0h;**
IRQ=3, 4, 11 Serial Port I/O port address is 2E0h and the interrupt address is IRQ3, 4, 11

5.3.3.4.2 Serial Port 5 Configuration

➔ Serial Port [Enabled]

Use the **Serial Port** option to enable or disable the serial port.

- ➔ **Disabled** Disable the serial port
- ➔ **Enabled** **DEFAULT** Enable the serial port

➔ Change Settings [IO=2D0h; IRQ=11;]

Use the **Change Settings** option to change the serial port IO port address and interrupt address.

- ➔ **IO=2D0h; DEFAULT** Serial Port I/O port address is 2D0h and the interrupt address is IRQ11
- ➔ **IO=3F8h;**
IRQ=3, 4, 11 Serial Port I/O port address is 3F8h and the interrupt address is IRQ3, 4, 11
- ➔ **IO=2F8h;**
IRQ=3, 4, 11 Serial Port I/O port address is 2F8h and the interrupt address is IRQ3, 4, 11
- ➔ **IO=3E8h;**
IRQ=3, 4, 11 Serial Port I/O port address is 3E8h and the interrupt address is IRQ3, 4, 11
- ➔ **IO=2E8h;**
IRQ=3, 4, 11 Serial Port I/O port address is 2E8h and the interrupt address is IRQ3, 4, 11

- ➔ **IO=2D0h;** Serial Port I/O port address is 2D0h and the interrupt address is IRQ3, 4, 11
 IRQ=3, 4, 11
- ➔ **IO=2E0h;** Serial Port I/O port address is 2E0h and the interrupt address is IRQ3, 4, 11
 IRQ=3, 4, 11

➔ Transfer Mode [RS232]

The serial port 5 allows setting the data transfer mode to RS-232, RS-422 or RS-485.

5.3.3.5 Parallel Port Configuration

Use the **Parallel Port Configuration** menu (**BIOS Menu 7**) to configure the parallel port.

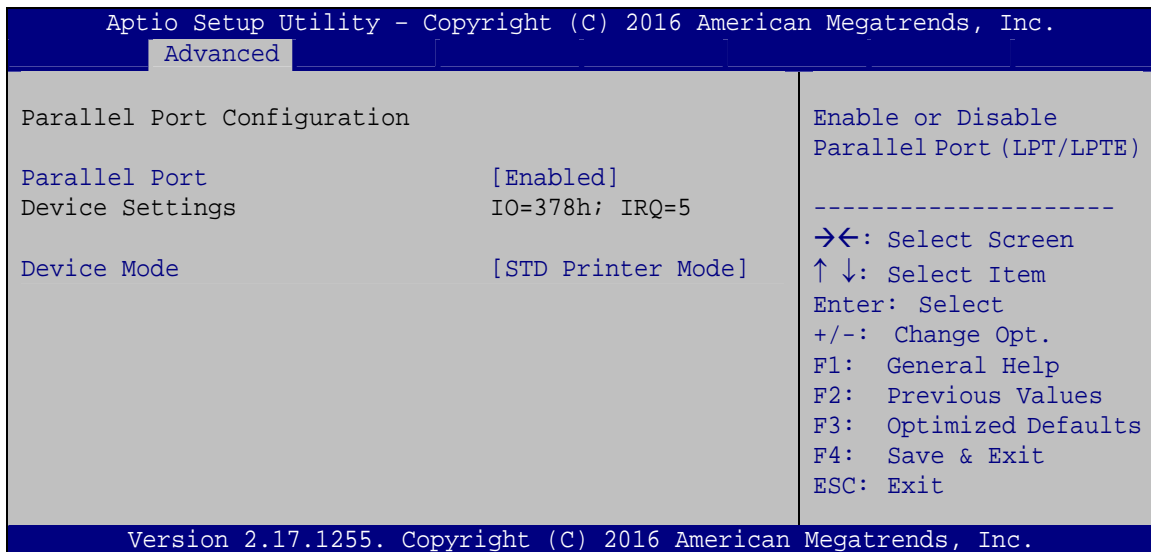

BIOS Menu 7: Parallel Port Configuration Menu

➔ Parallel Port [Enabled]

Use the **Parallel Port** option to enable or disable the parallel port.

- ➔ **Disabled** Disable the parallel port
- ➔ **Enabled DEFAULT** Enable the parallel port

IMBA-H110 ATX Motherboard

→ Device Mode [STD Printer Mode]

Use the **Device Mode** option to select the mode the parallel port operates in. Configuration options are listed below.

- STD Printer Mode **Default**
- SPP Mode
- EPP-1.9 and SPP Mode
- EPP-1.7 and SPP Mode
- ECP Mode
- ECP and EPP 1.9 Mode
- ECP and EPP 1.7 Mode

5.3.4 iWDD H/W Monitor

The **iWDD H/W Monitor** menu (**BIOS Menu 8**) contains the fan configuration submenu, and displays operating temperature, fan speeds and system voltages.

```

Aptio Setup Utility - Copyright (C) 2016 American Megatrends, Inc.
Advanced
PC Health Status
CPU temperature           : +54°C
SYS temperature          : +24°C

CPU_FAN1 Speed           : 1210 RPM
SYS_FAN1 Speed           : N/A

CPU_CORE                  : +0.964 V
+5V                       : +5.131 V
+12V                      : +12.161 V
+DDR                      : +1.202 V
+5VSB                     : +5.099 V
+3.3V                     : +3.343 V
+3.3VSB                   : +3.323 V

> Smart Fan Mode Configuration

Smart Fan Mode Select

-----
→←: Select Screen
↑↓: Select Item
Enter: Select
+/-: Change Opt.
F1: General Help
F2: Previous Values
F3: Optimized Defaults
F4: Save & Exit
ESC: Exit

Version 2.17.1255. Copyright (C) 2016 American Megatrends, Inc.
    
```

BIOS Menu 8: iWDD H/W Monitor

→ PC Health Status

The following system parameters and values are shown. The system parameters that are monitored are:

- System Temperatures:
 - CPU Temperature
 - System Temperature
- Fan Speed:
 - CPU Fan Speed
 - System Fan Speed
- Voltages:
 - CPU_CORE
 - +5V
 - +12V
 - +DDR
 - +5VSB
 - +3.3V
 - +3.3VSB

5.3.4.1 Smart Fan Mode Configuration

Use the **Smart Fan Mode Configuration** submenu (**BIOS Menu 9**) to configure the CPU/system fan temperature and speed settings.

```

Aptio Setup Utility - Copyright (C) 2016 American Megatrends, Inc.
Advanced
Smart Fan Mode Configuration
CPU_FAN1 Smart Fan Control      [Auto Mode]
Auto mode fan start temperature 50
Auto mode fan off temperature  40
Auto mode fan start PWM        30
Auto mode fan slope PWM        1

SYS_FAN1 Smart Fan Control      [Auto Mode]
Auto mode fan start temperature 50
Auto mode fan off temperature  40
Auto mode fan start PWM        30
Auto mode fan slope PWM        1

Smart Fan Mode Select
-----
-><-: Select Screen
↑ ↓: Select Item
Enter: Select
+/-: Change Opt.
F1:  General Help
F2:  Previous Values
F3:  Optimized Defaults
F4:  Save & Exit
ESC: Exit

Version 2.17.1255. Copyright (C) 2016 American Megatrends, Inc.
    
```

BIOS Menu 9: Smart Fan Mode Configuration

IMBA-H110 ATX Motherboard

→ CPU_FAN1 Smart Fan Control/SYS_FAN1 Smart Fan Control [Auto Mode]

Use the **CPU_FAN1 Smart Fan Control/SYS_FAN1 Smart Fan Control** option to configure the CPU/System Smart Fan.

→ **Auto Mode** **DEFAULT** The fan adjusts its speed using Auto Mode settings.

→ **Manual Mode** The fan spins at the speed set in Manual Mode settings.

→ Auto mode fan start/off temperature

Use the + or – key to change the **Auto mode fan start/off temperature** value. Enter a decimal number between 1 and 100.

→ Auto mode fan start PWM

Use the + or – key to change the **Auto mode fan start PWM** value. Enter a decimal number between 1 and 100.

→ Auto mode fan slope PWM

Use the + or – key to change the **Auto mode fan slope PWM** value. Enter a decimal number between 1 and 8.

5.3.5 RTC Wake Settings

The **RTC Wake Settings** menu (**BIOS Menu 10**) enables the system to wake at the specified time.

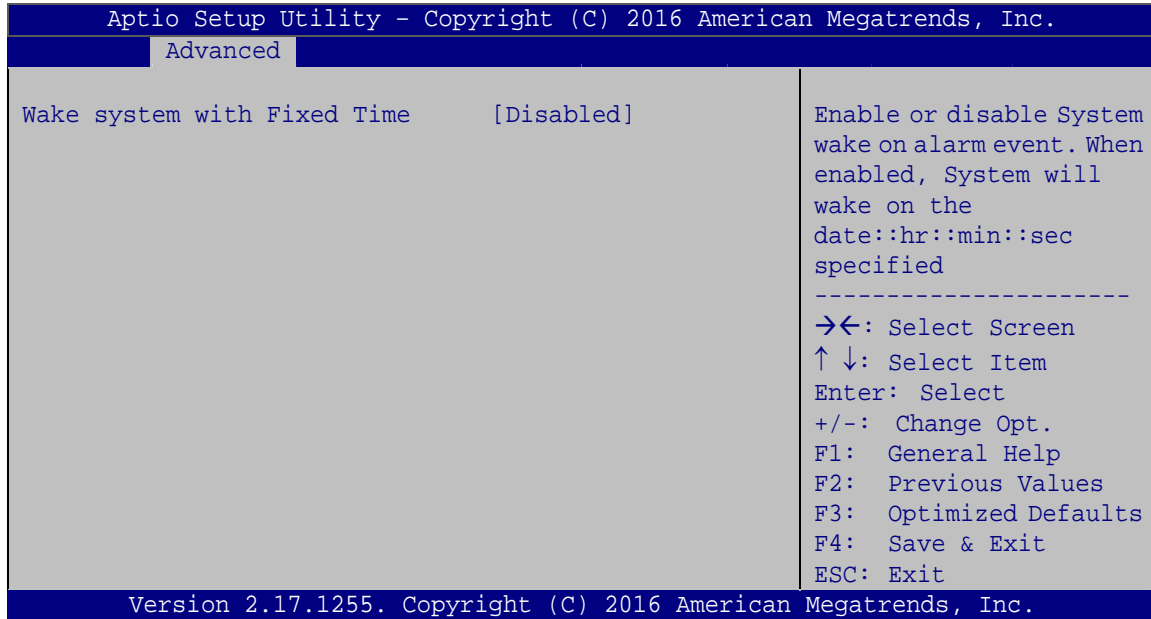

BIOS Menu 10: RTC Wake Settings

→ Wake system with Fixed Time [Disabled]

Use the **Wake system with Fixed Time** option to enable or disable the system wake on alarm event.

→ **Disabled** **DEFAULT** The real time clock (RTC) cannot generate a wake event.

→ **Enabled** If selected, the **Wake up every day** option appears allowing you to enable to disable the system to wake every day at the specified time. Besides, the following options appear with values that can be selected:

Wake up date

Wake up hour

Wake up minute

Wake up second

After setting the alarm, the computer turns itself on from a suspend state when the alarm goes off.

IMBA-H110 ATX Motherboard

5.3.6 Serial Port Console Redirection

The **Serial Port Console Redirection** menu (**BIOS Menu 11**) allows the console redirection options to be configured. Console redirection allows users to maintain a system remotely by re-directing keyboard input and text output through the serial port.

```

Aptio Setup Utility - Copyright (C) 2016 American Megatrends, Inc.
  Advanced
COM1
  Console Redirection          [Disabled]
  > Console Redirection Settings
COM2
  Console Redirection          [Disabled]
  > Console Redirection Settings
COM3
  Console Redirection          [Disabled]
  > Console Redirection Settings
COM4
  Console Redirection          [Disabled]
  > Console Redirection Settings
COM5
  Console Redirection          [Disabled]
  > Console Redirection Settings
Legacy Console Redirection
  > Legacy Console Redirection Settings

-----
-><: Select Screen
↑↓: Select Item
Enter: Select
+/-: Change Opt.
F1: General Help
F2: Previous Values
F3: Optimized Defaults
F4: Save & Exit
ESC: Exit

Version 2.17.1255. Copyright (C) 2016 American Megatrends, Inc.
  
```

BIOS Menu 11: Serial Port Console Redirection

→ Console Redirection [Disabled]

Use **Console Redirection** option to enable or disable the console redirection function.

- **Disabled** **DEFAULT** Disabled the console redirection function
- **Enabled** Enabled the console redirection function

The following options are available in the **Console Redirection Settings** submenu when the **Console Redirection** option is enabled.

→ Terminal Type [ANSI]

Use the **Terminal Type** option to specify the remote terminal type.

- VT100 The target terminal type is VT100
- VT100+ The target terminal type is VT100+
- VT-UTF8 The target terminal type is VT-UTF8
- ANSI **DEFAULT** The target terminal type is ANSI

→ **Bits per second [115200]**

Use the **Bits per second** option to specify the serial port transmission speed. The speed must match the other side. Long or noisy lines may require lower speeds.

- 9600 Sets the serial port transmission speed at 9600.
- 19200 Sets the serial port transmission speed at 19200.
- 57600 Sets the serial port transmission speed at 57600.
- 115200 **DEFAULT** Sets the serial port transmission speed at 115200.

→ **Data Bits [8]**

Use the **Data Bits** option to specify the number of data bits.

- 7 Sets the data bits at 7.
- 8 **DEFAULT** Sets the data bits at 8.

→ **Parity [None]**

Use the **Parity** option to specify the parity bit that can be sent with the data bits for detecting the transmission errors.

- **None** **DEFAULT** No parity bit is sent with the data bits.
- **Even** The parity bit is 0 if the number of ones in the data bits is even.
- **Odd** The parity bit is 0 if the number of ones in the data bits is odd.

IMBA-H110 ATX Motherboard

- ➔ **Mark** The parity bit is always 1. This option does not provide error detection.
- ➔ **Space** The parity bit is always 0. This option does not provide error detection.

➔ **Stop Bits [1]**

Use the **Stop Bits** option to specify the number of stop bits used to indicate the end of a serial data packet. Communication with slow devices may require more than 1 stop bit.

- ➔ **1** **DEFAULT** Sets the number of stop bits at 1.
- ➔ **2** Sets the number of stop bits at 2.

5.3.6.1 Legacy Console Redirection Settings

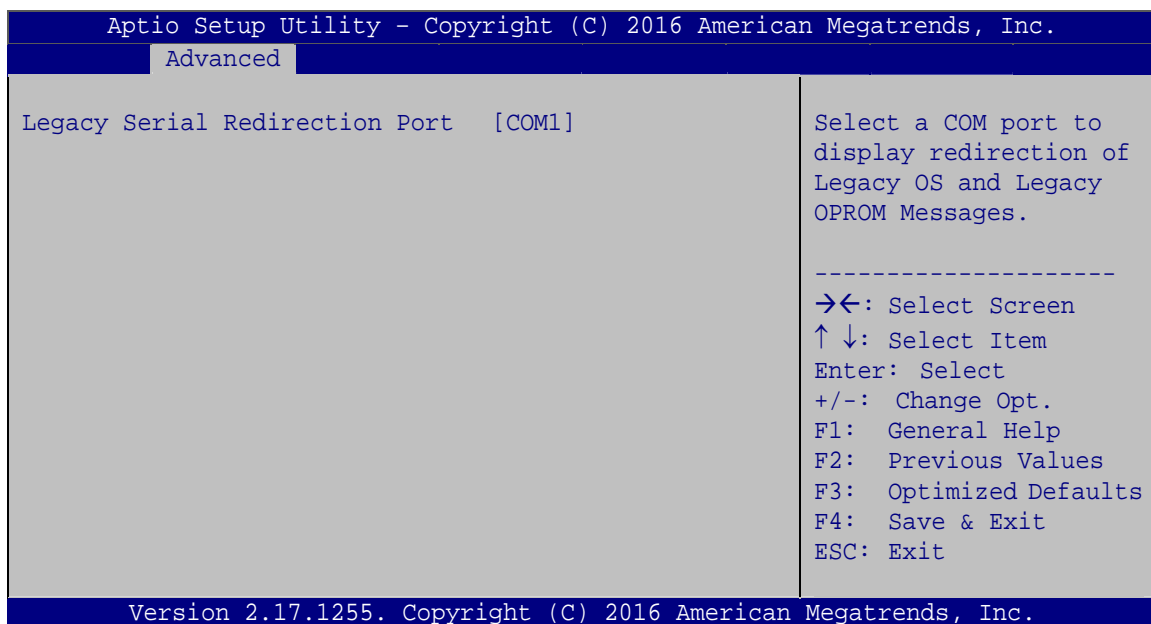

BIOS Menu 12: Legacy Console Redirection Settings

➔ **Legacy Serial Redirection Port [COM1]**

Use the Legacy Serial Redirection Port option to select a COM port to display redirection of legacy OS and legacy OPRM messages.

5.3.7 CPU Configuration

Use the **CPU Configuration** menu (**BIOS Menu 13**) to view detailed CPU specifications or enable the Intel Virtualization Technology.

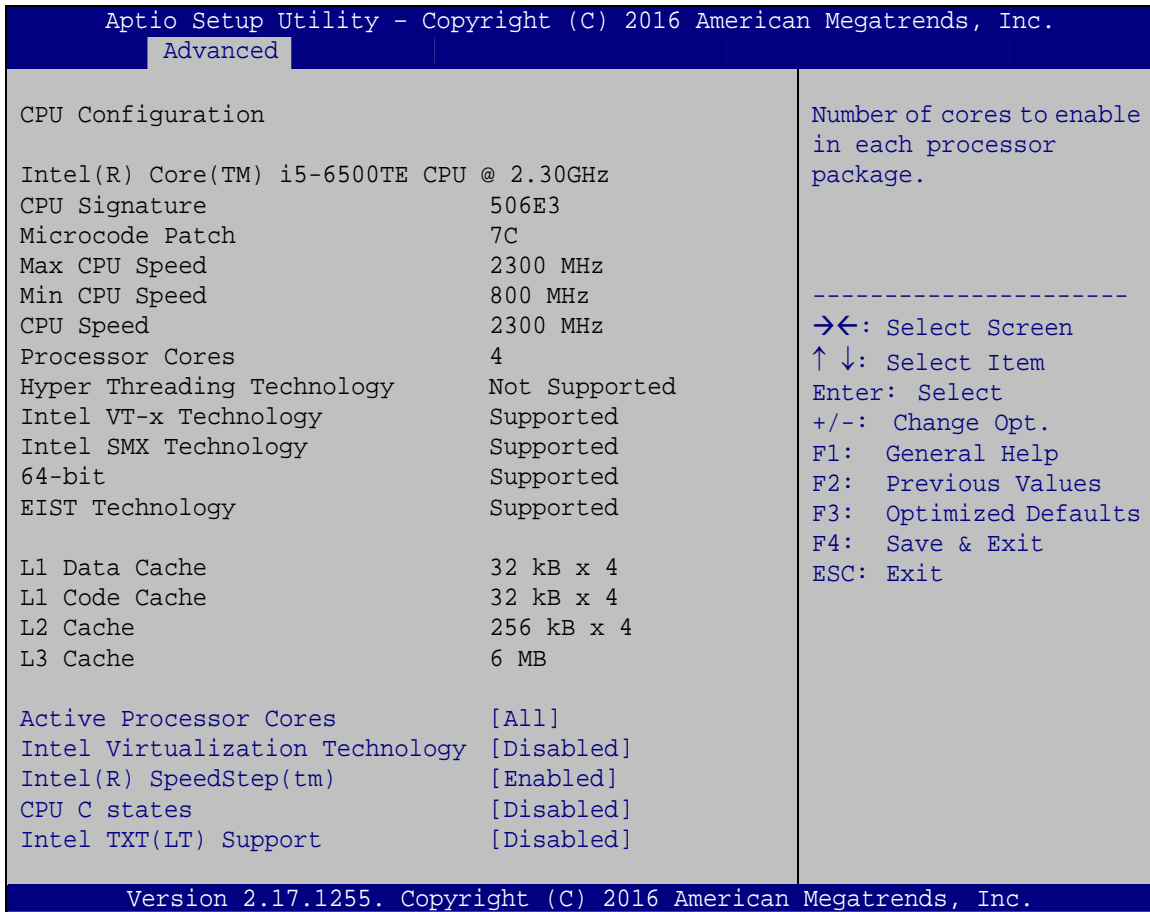

Aptio Setup Utility - Copyright (C) 2016 American Megatrends, Inc.

Advanced

CPU Configuration		Number of cores to enable in each processor package.
Intel(R) Core(TM) i5-6500TE CPU @ 2.30GHz		
CPU Signature	506E3	
Microcode Patch	7C	
Max CPU Speed	2300 MHz	
Min CPU Speed	800 MHz	
CPU Speed	2300 MHz	
Processor Cores	4	
Hyper Threading Technology	Not Supported	
Intel VT-x Technology	Supported	
Intel SMX Technology	Supported	
64-bit	Supported	
EIST Technology	Supported	
L1 Data Cache	32 kB x 4	
L1 Code Cache	32 kB x 4	
L2 Cache	256 kB x 4	
L3 Cache	6 MB	
Active Processor Cores	[All]	
Intel Virtualization Technology	[Disabled]	
Intel(R) SpeedStep(tm)	[Enabled]	
CPU C states	[Disabled]	
Intel TXT(LT) Support	[Disabled]	

 →←: Select Screen
 ↑ ↓: Select Item
 Enter: Select
 +/-: Change Opt.
 F1: General Help
 F2: Previous Values
 F3: Optimized Defaults
 F4: Save & Exit
 ESC: Exit

Version 2.17.1255. Copyright (C) 2016 American Megatrends, Inc.

BIOS Menu 13: CPU Configuration

→ Active Processor Cores [All]

Use the **Active Processor Cores** BIOS option to enable numbers of cores in the processor package.

- **All** **DEFAULT** Enable all cores in the processor package.
- **1** Enable one core in the processor package.
- **2** Enable two cores in the processor package.
- **3** Enable **three cores** in the processor package.

IMBA-H110 ATX Motherboard

→ Intel Virtualization Technology [Disabled]

Use the **Intel Virtualization Technology** option to enable or disable virtualization on the system. When combined with third party software, Intel® Virtualization technology allows several OSs to run on the same system at the same time.

- **Disabled** **DEFAULT** Disables Intel Virtualization Technology.
- **Enabled** Enables Intel Virtualization Technology.

→ Intel(R) SpeedStep(tm) [Enabled]

Use the **Intel(R) SpeedStep(tm)** option to enable or disable the Intel® SpeedStep Technology which allows more than two frequency ranges to be supported.

- **Disabled** Disables Intel® SpeedStep Technology
- **Enabled** **DEFAULT** Enables Intel® SpeedStep Technology

→ CPU C states [Disabled]

Use the **CPU C states** option to enable or disable the CPU C states.

- **Disabled** **DEFAULT** Disables the CPU C states.
- **Enabled** Enables the CPU C states.

→ Intel TXT(LT) Support [Disabled]

Use the **Intel TXT(LT) Support** option to enable or disable the Intel(R) TXT(LT) support.

- **Disabled** **DEFAULT** Disables Intel® TXT(LT) support
- **Enabled** Enables Intel® TXT(LT) support

5.3.8 SATA Configuration

Use the **SATA Configuration** menu (**BIOS Menu 14**) to change and/or set the configuration of the SATA devices installed in the system.

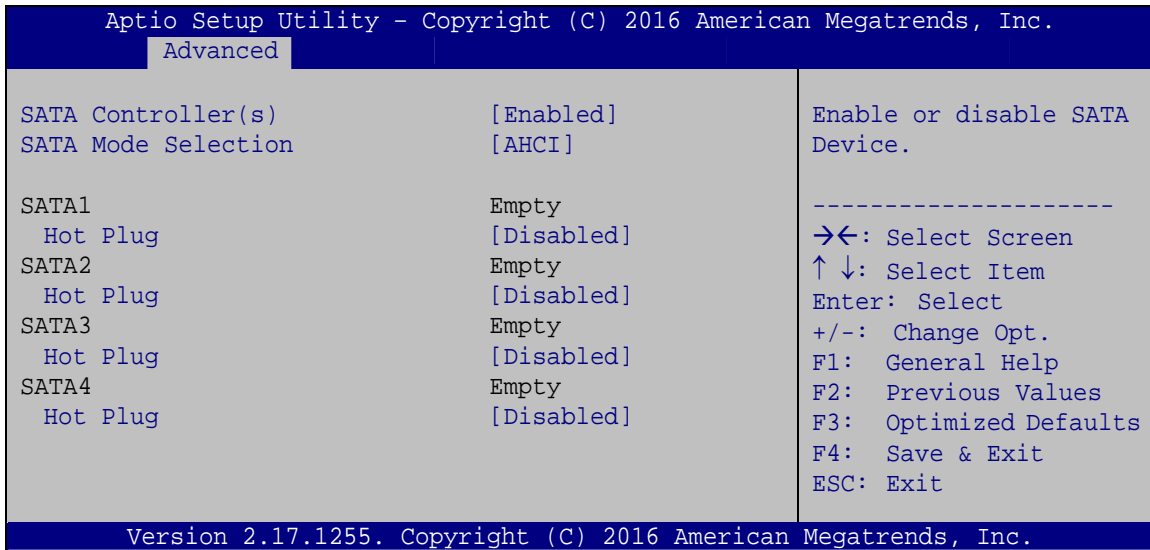

BIOS Menu 14: SATA Configuration

→ SATA Controller(s) [Enabled]

Use the **SATA Controller(s)** option to configure the SATA controller(s).

- **Enabled** **DEFAULT** Enables the on-board SATA controller(s).
- **Disabled** Disables the on-board SATA controller(s).

→ SATA Mode Selection [AHCI]

Use the **SATA Mode Selection** option to determine how the SATA devices operate.

- **AHCI** **DEFAULT** Configures SATA devices as AHCI device.

→ Hot Plug [Disabled]

Use the **Hot Plug** option to designate the correspondent SATA port as hot-pluggable.

- **Disabled** **DEFAULT** Disables the hot-pluggable function of the SATA port.
- **Enabled** Designates the SATA port as hot-pluggable.

IMBA-H110 ATX Motherboard

5.3.9 NVMe Configuration

Use the **NVMe Configuration (BIOS Menu 15)** menu to display the NVMe controller and device information.

```
Aptio Setup Utility - Copyright (C) 2016 American Megatrends, Inc.
Advanced
NVMe controller and Drive information
No NVMe Device Found
-----
-><: Select Screen
↑↓: Select Item
Enter: Select
+/-: Change Opt.
F1: General Help
F2: Previous Values
F3: Optimized Defaults
F4: Save & Exit
ESC: Exit
Version 2.17.1255. Copyright (C) 2016 American Megatrends, Inc.
```

BIOS Menu 15: NVMe Configuration

5.3.10 USB Configuration

Use the **USB Configuration** menu (**BIOS Menu 16**) to read USB configuration information and configure the USB settings.

```

Aptio Setup Utility - Copyright (C) 2016 American Megatrends, Inc.
  Advanced
USB Configuration
USB Controllers:
  1 XHCI
USB Devices:
  1 Keyboard, 1 Hub
Legacy USB Support          [Enabled]
-----
-><: Select Screen
↑ ↓: Select Item
Enter: Select
+/-: Change Opt.
F1:  General Help
F2:  Previous Values
F3:  Optimized Defaults
F4:  Save & Exit
ESC: Exit
Version 2.17.1255. Copyright (C) 2016 American Megatrends, Inc.
  
```

BIOS Menu 16: USB Configuration

➔ Legacy USB Support [Enabled]

Use the **Legacy USB Support** BIOS option to enable USB mouse and USB keyboard support. Normally if this option is not enabled, any attached USB mouse or USB keyboard does not become available until a USB compatible operating system is fully booted with all USB drivers loaded. When this option is enabled, any attached USB mouse or USB keyboard can control the system even when there is no USB driver loaded onto the system.

- ➔ **Enabled** **DEFAULT** Legacy USB support enabled
- ➔ **Disabled** Legacy USB support disabled
- ➔ **Auto** Legacy USB support disabled if no USB devices are connected

IMBA-H110 ATX Motherboard

5.3.11 iEi Feature

Use the **iEi Feature** menu (**BIOS Menu 17**) to configure One Key Recovery function.

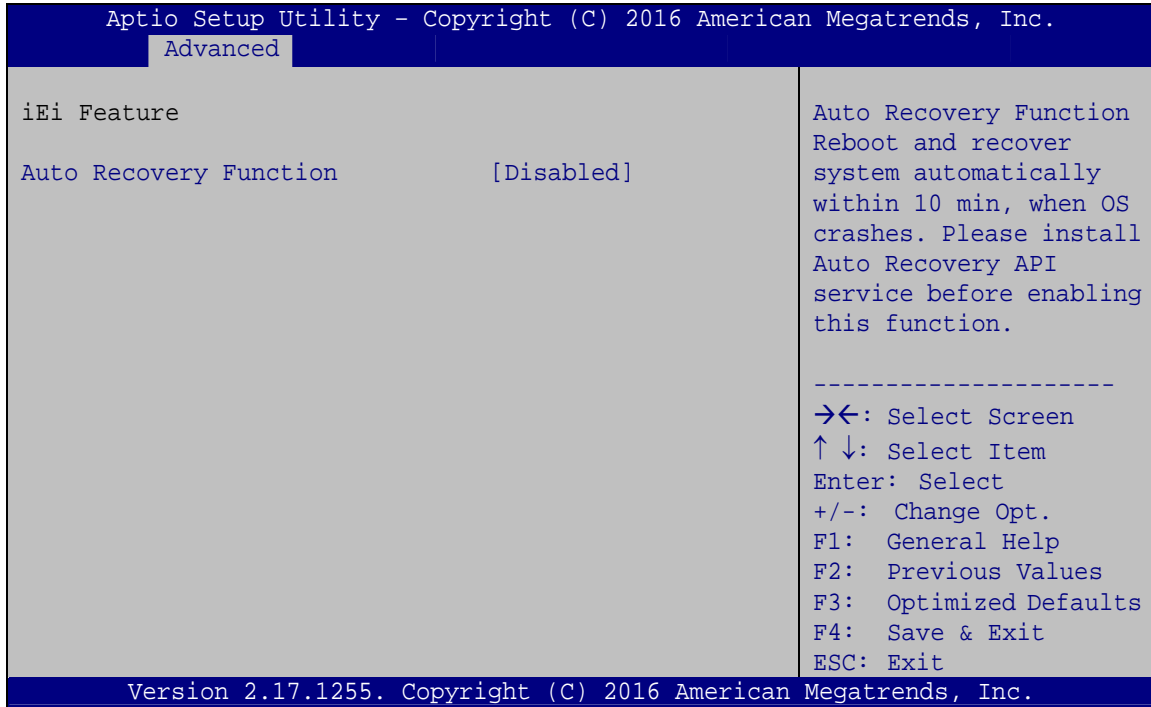

BIOS Menu 17: iEi Feature

→ Auto Recovery Function [Disabled]

Use the **Auto Recovery Function** BIOS option to enable or disable the auto recovery function of the IEI One Key Recovery.

- **Disabled** **DEFAULT** Auto recovery function disabled
- **Enabled** Auto recovery function enabled

5.4 Chipset

Use the **Chipset** menu (**BIOS Menu 18**) to access the PCH IO and System Agent (SA) configuration menus.



WARNING!

Setting the wrong values for the Chipset BIOS selections in the Chipset BIOS menu may cause the system to malfunction.

```
Aptio Setup Utility - Copyright (C) 2016 American Megatrends, Inc.
Main   Advanced  Chipset  Security  Boot   Save & Exit
-----
> System Agent (SA) Configuration      System Agent (SA)
> PCH-IO Configuration                Parameters
-----
-><: Select Screen
↑↓: Select Item
Enter: Select
+/-: Change Opt.
F1: General Help
F2: Previous Values
F3: Optimized Defaults
F4: Save & Exit
ESC: Exit

Version 2.17.1255. Copyright (C) 2016 American Megatrends, Inc.
```

BIOS Menu 18: Chipset

IMBA-H110 ATX Motherboard

5.4.1 System Agent (SA) Configuration

Use the **System Agent (SA) Configuration** menu (**BIOS Menu 19**) to configure the System Agent (SA) parameters.

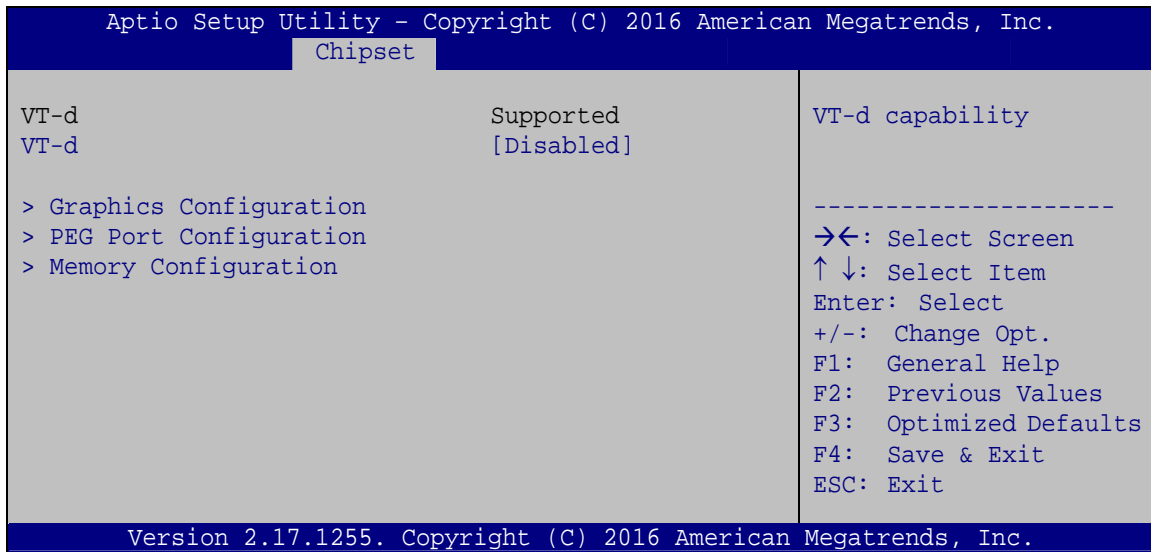

BIOS Menu 19: System Agent (SA) Configuration

→ VT-d [Disabled]

Use the **VT-d** option to enable or disable VT-d capability.

- **Disabled** **DEFAULT** Disables VT-d capability.
- **Enabled** Enables VT-d capability.

5.4.1.1 Graphics Configuration

Use the **Graphics Configuration (BIOS Menu 20)** menu to configure the video device connected to the system.

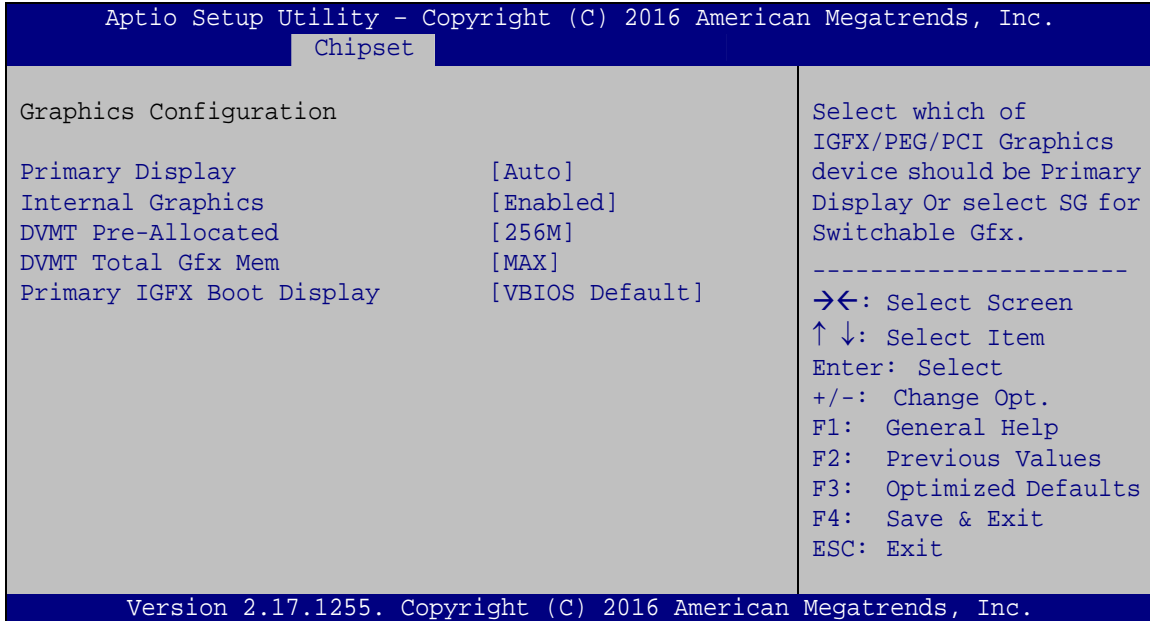

BIOS Menu 20: Graphics Configuration

→ Primary Display [Auto]

Use the **Primary Display** option to select the primary graphics controller the system uses.

The following options are available:

- Auto **Default**
- IGFX
- PEG
- PCIE

→ Internal Graphics [Enabled]

Use the **Internal Graphics** option to keep IGFX enabled basing on the setup options. The following options are available:

- Auto
- Disabled
- Enabled **Default**

IMBA-H110 ATX Motherboard

→ DVMT Pre-Allocated [256M]

Use the **DVMT Pre-Allocated** option to set the amount of system memory allocated to the integrated graphics processor when the system boots. The system memory allocated can then only be used as graphics memory, and is no longer available to applications or the operating system. Configuration options are listed below:

- 32M
- 64M
- 128M
- 256M **Default**
- 512M

→ DVMT Total Gfx Mem [MAX]

Use the **DVMT Total Gfx Mem** option to select DVMT5.0 total graphic memory size used by the internal graphic device. The following options are available:

- 128M
- 256M
- MAX **Default**

→ Primary IGFX Boot Display [VBIOS Default]

Use the **Primary IGFX Boot Display** option to select the display device used by the system when it boots. Configuration options are listed below.

- VBIOS Default **Default**
- HDMI
- CRT
- IDP
- DVI

5.4.1.2 PEG Port Configuration

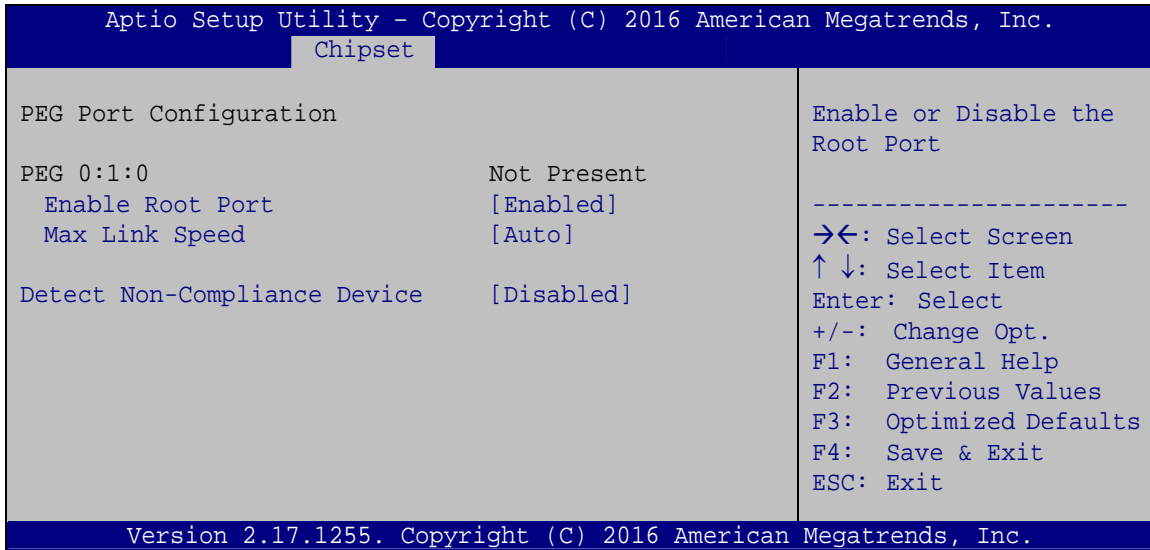

BIOS Menu 21: PEG Port Configuration

→ Enable Root Port [Enabled]

Use the **Enable Root Port** option to enable or disable the PCI Express (PEG) controller.

- **Disabled** Disables the PCI Express (PEG) controller.
- **Enabled** **DEFAULT** Enables the PCI Express (PEG) controller.

→ Max Link Speed [Auto]

Use the **Max Link Speed** option to select the maximum link speed of the PCI Express slot.

The following options are available:

- Auto **Default**
- Gen1
- Gen2
- Gen3

→ Detect Non-Compliance Device [Disabled]

Use the **Detect Non-Compliance Device** option to enable or disable detecting if a non-compliance PCI Express device is connected to the PCI Express slot.

IMBA-H110 ATX Motherboard

- | | | | |
|---|-----------------|----------------|---|
| ➔ | Disabled | DEFAULT | Disables to detect if a non-compliance PCI Express device is connected to the PCI Express slot. |
| ➔ | Enabled | | Enables to detect if a non-compliance PCI Express device is connected to the PCI Express slot. |

5.4.1.3 Memory Configuration

Use the **Memory Configuration** submenu (**BIOS Menu 22**) to view memory information.

```

Aptio Setup Utility - Copyright (C) 2016 American Megatrends, Inc.
Chipset
Memory Configuration
Total Memory                4096 MB
CHA_DIMM0                   Not Present
CHB_DIMM0                   4096 MB
-----
➔←: Select Screen
↑ ↓: Select Item
Enter: Select
+/-: Change Opt.
F1: General Help
F2: Previous Values
F3: Optimized Defaults
F4: Save & Exit
ESC: Exit
Version 2.17.1255. Copyright (C) 2016 American Megatrends, Inc.

```

BIOS Menu 22: Memory Configuration

5.4.2 PCH-IO Configuration

Use the **PCH-IO Configuration** menu (**BIOS Menu 23**) to configure the PCH parameters.

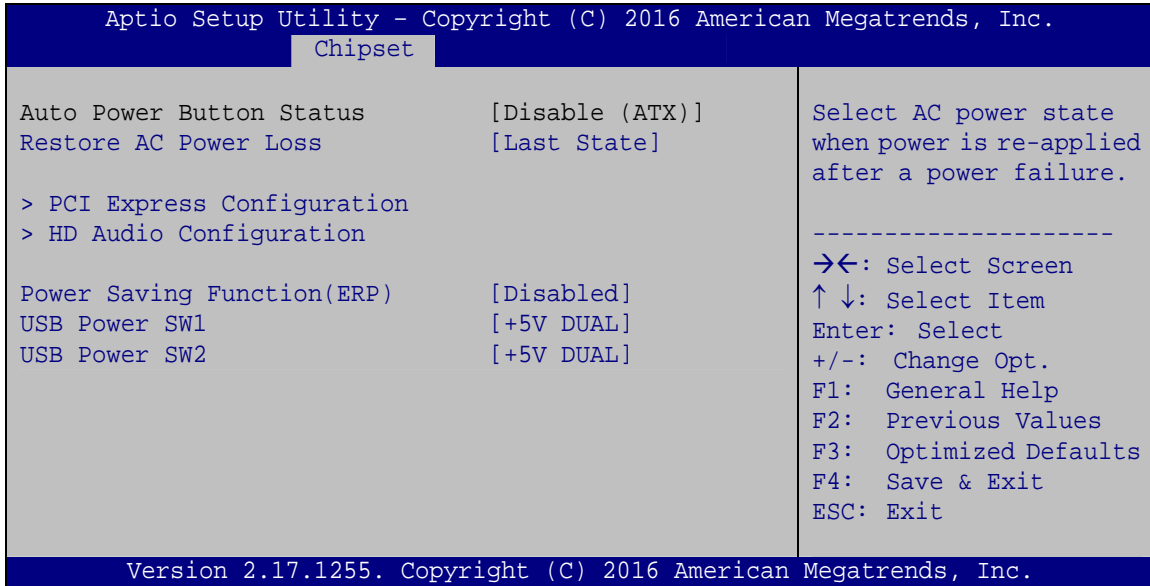

BIOS Menu 23: PCH-IO Configuration

→ Restore AC Power Loss [Last State]

Use the **Restore AC Power Loss** BIOS option to specify what state the system returns to if there is a sudden loss of power to the system.

- **Power Off** The system remains turned off.
- **Power On** The system turns on.
- **Last State** **DEFAULT** The system returns to its previous state. If it was on, it turns itself on. If it was off, it remains off.

→ Power Saving Function(ERP) [Disabled]

Use the **Power Saving Function(ERP)** BIOS option to enable or disable the power saving function.

- **Disabled** **DEFAULT** Power saving function is disabled.
- **Enabled** Power saving function is enabled. It will reduce power consumption when the system is off.

IMBA-H110 ATX Motherboard

→ USB Power SW1 [+5V DUAL]

Use the **USB Power SW1** BIOS option to configure the USB power source for the corresponding USB connectors (**Table 5-2**).

→ **+5V DUAL** **DEFAULT** Sets the USB power source to +5V dual

→ **+5V** Sets the USB power source to +5V

→ USB Power SW2 [+5V DUAL]

Use the **USB Power SW2** BIOS option to configure the USB power source for the corresponding USB connectors (**Table 5-2**).

→ **+5V DUAL** **DEFAULT** Sets the USB power source to +5V dual

→ **+5V** Sets the USB power source to +5V

BIOS Options	Configured USB Ports
USB Power SW1	LAN1_USB1 (external USB 3.0 ports) LAN2_USB2 (external USB 3.0 ports) K/M_USB1 (external USB 2.0 ports)
USB Power SW2	USB1 (internal USB 2.0 ports) USB2-3 (internal USB 2.0 port, Type A)

Table 5-2: BIOS Options and Configured USB Ports

5.4.2.1 PCI Express Configuration

Use the **PCI Express Configuration** submenu (**BIOS Menu 24**) to configure the PCIe Mini slot.

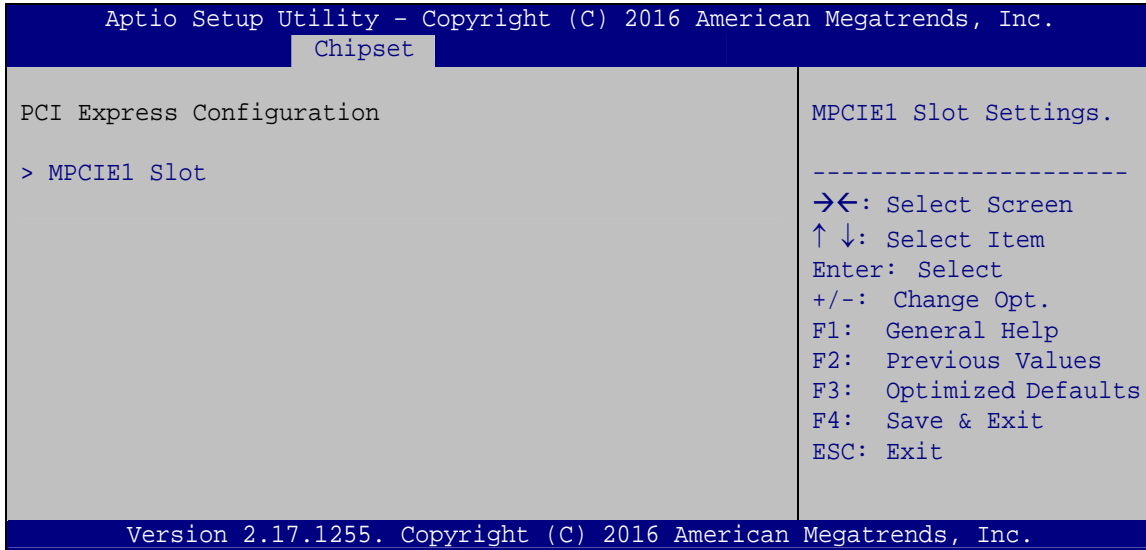

BIOS Menu 24: PCI Express Configuration

5.4.2.1.1 MPCIE1 Slot

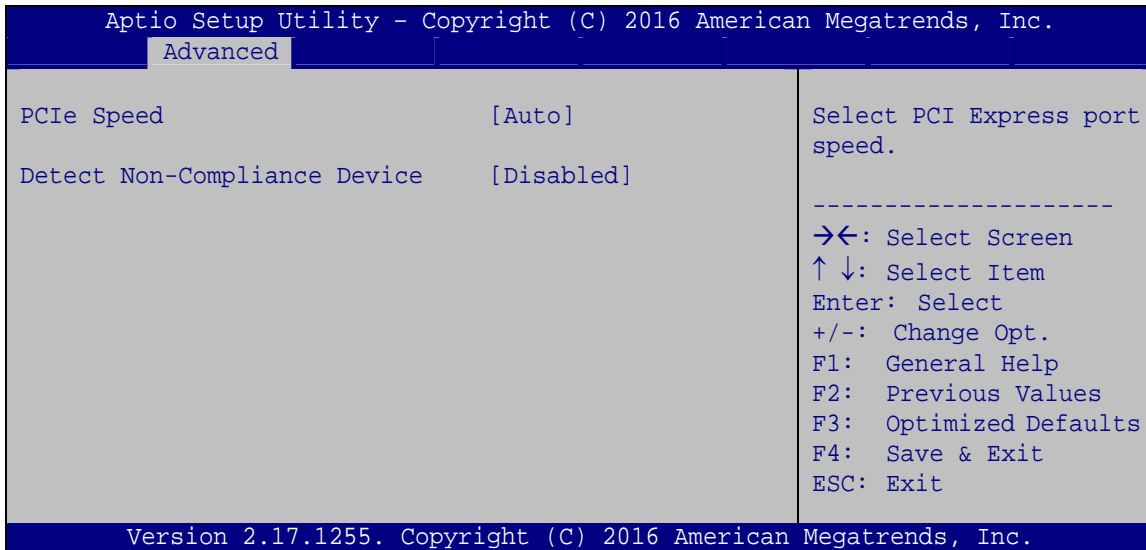

BIOS Menu 25: MPCIE1 Slot

IMBA-H110 ATX Motherboard

→ PCIe Speed [Auto]

Use this option to select the support type of the PCI Express slots. The following options are available:

- Auto **Default**
- Gen1
- Gen2
- Gen3

→ Detect Non-Compliance Device [Disabled]

Use the **Detect Non-Compliance Device** option to enable or disable detecting if a non-compliance PCI Express device is connected to the PCI Express slot.

- **Disabled** **DEFAULT** Disables to detect if a non-compliance PCI Express device is connected to the PCI Express slot.

- **Enabled** Enables to detect if a non-compliance PCI Express device is connected to the PCI Express slot.

5.4.2.2 HD Audio Configuration

Use the **HD Audio Configuration** menu (**BIOS Menu 26**) to configure the PCH Azalia settings.

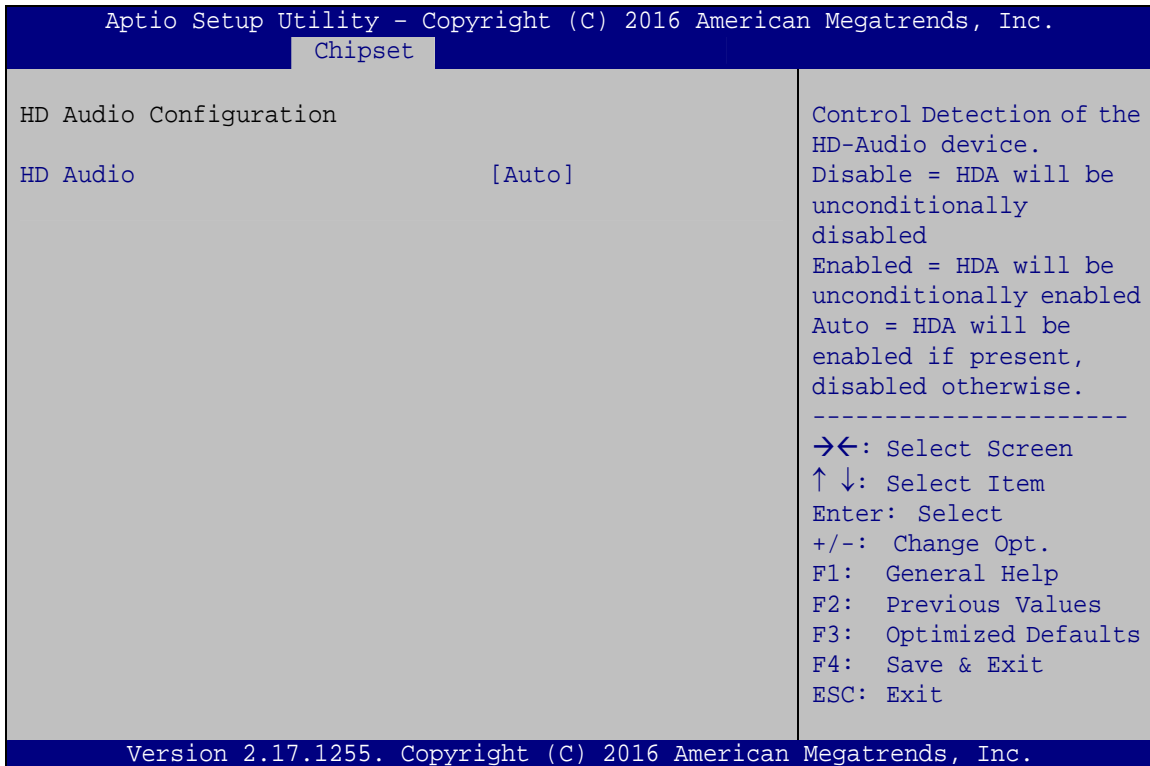

BIOS Menu 26: HD Audio Configuration

→ HD Audio [Auto]

Use the **HD Audio** option to enable or disable the High Definition Audio controller.

- **Disabled** The onboard High Definition Audio controller is disabled.
- **Enabled** The onboard High Definition Audio controller is enabled.
- **Auto** **DEFAULT** The onboard High Definition Audio controller automatically detected and enabled

IMBA-H110 ATX Motherboard

5.5 Security

Use the **Security** menu (**BIOS Menu 27**) to set system and user passwords.

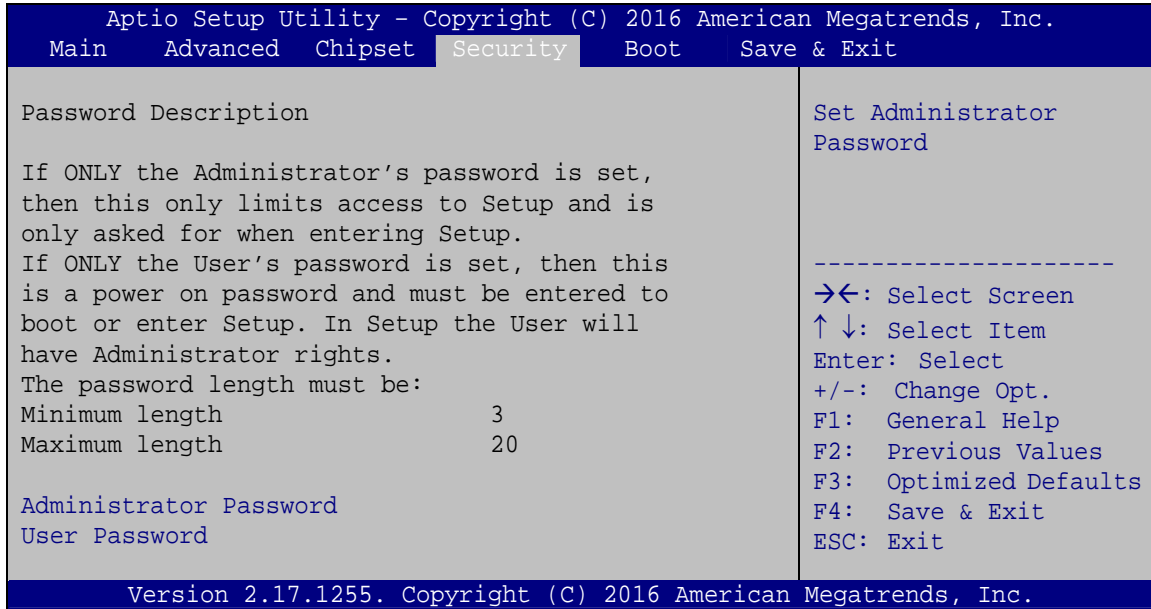

BIOS Menu 27: Security

→ Administrator Password

Use the **Administrator Password** to set or change a administrator password.

→ User Password

Use the **User Password** to set or change a user password.

5.6 Boot

Use the **Boot** menu (**BIOS Menu 28**) to configure system boot options.

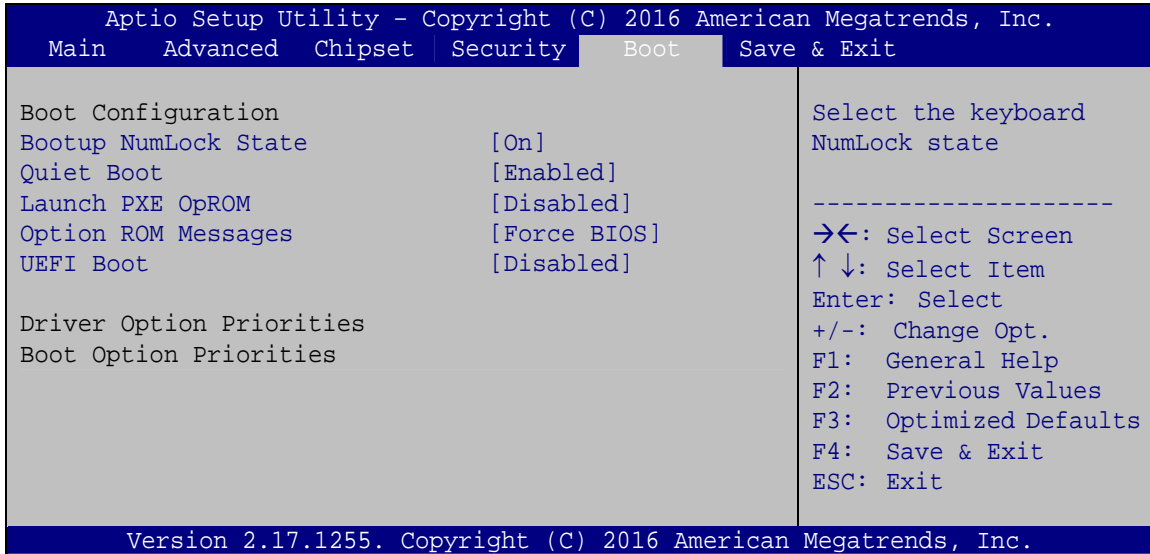

BIOS Menu 28: Boot

→ Bootup NumLock State [On]

Use the **Bootup NumLock State** BIOS option to specify if the number lock setting must be modified during boot up.

- **On** **DEFAULT** Allows the Number Lock on the keyboard to be enabled automatically when the computer system boots up. This allows the immediate use of the 10-key numeric keypad located on the right side of the keyboard. To confirm this, the Number Lock LED light on the keyboard is lit.

- **Off** Does not enable the keyboard Number Lock automatically. To use the 10-keys on the keyboard, press the Number Lock key located on the upper left-hand corner of the 10-key pad. The Number Lock LED on the keyboard lights up when the Number Lock is engaged.

IMBA-H110 ATX Motherboard

→ Quiet Boot [Enabled]

Use the **Quiet Boot** BIOS option to select the screen display when the system boots.

- **Disabled** Normal POST messages displayed
- **Enabled** **DEFAULT** OEM Logo displayed instead of POST messages

→ Launch PXE OpROM [Disabled]

Use the **Launch PXE OpROM** option to enable or disable boot option for legacy network devices.

- **Disabled** **DEFAULT** Ignore all PXE Option ROMs
- **Enabled** Load PXE Option ROMs.

→ Option ROM Messages [Force BIOS]

Use the **Option ROM Messages** option to set the Option ROM display mode.

- **Force BIOS** **DEFAULT** Sets display mode to force BIOS.
- **Keep Current** Sets display mode to current.

→ UEFI Boot [Disabled]

Use the **UEFI Boot** option to enable or disable to boot from the UEFI devices.

- **Enabled** Boot from UEFI devices is enabled.
- **Disabled** **DEFAULT** Boot from UEFI devices is disabled.

5.7 Save & Exit

Use the **Safe & Exit** menu (**BIOS Menu 29**) to load default BIOS values, optimal failsafe values and to save configuration changes.

```
Aptio Setup Utility - Copyright (C) 2016 American Megatrends, Inc.
Main   Advanced  Chipset  Security  Boot   Save & Exit
-----
Save Changes and Reset
Discard Changes and Reset

Restore Defaults
Save as User Defaults
Restore User Defaults

Reset the system after
saving the changes.

-----
-><: Select Screen
↑↓: Select Item
Enter: Select
+/-: Change Opt.
F1: General Help
F2: Previous Values
F3: Optimized Defaults
F4: Save & Exit
ESC: Exit

Version 2.17.1255. Copyright (C) 2016 American Megatrends, Inc.
```

BIOS Menu 29: Save & Exit

→ Save Changes and Reset

Use the **Save Changes and Reset** option to save the changes made to the BIOS options and reset the system.

→ Discard Changes and Reset

Use the **Discard Changes and Reset** option to exit the system without saving the changes made to the BIOS configuration setup program.

→ Restore Defaults

Use the **Restore Defaults** option to load the optimal default values for each of the parameters on the Setup menus. **F3 key can be used for this operation.**

→ Save as User Defaults

Use the **Save as User Defaults** option to save the changes done so far as user defaults.

→ Restore User Defaults

Use the **Restore User Defaults** option to restore the user defaults to all the setup options.

Appendix

A

Regulatory Compliance

DECLARATION OF CONFORMITY

This equipment has been tested and found to comply with specifications for CE marking. If the user modifies and/or installs other devices in the equipment, the CE conformity declaration may no longer apply.

FCC WARNING

This equipment complies with Part 15 of the FCC Rules. Operation is subject to the following two conditions:

- This device may not cause harmful interference, and
- This device must accept any interference received, including interference that may cause undesired operation.

This equipment has been tested and found to comply with the limits for a Class A digital device, pursuant to part 15 of the FCC Rules. These limits are designed to provide reasonable protection against harmful interference when the equipment is operated in a commercial environment. This equipment generates, uses, and can radiate radio frequency energy and, if not installed and used in accordance with the instruction manual, may cause harmful interference to radio communications. Operation of this equipment in a residential area is likely to cause harmful interference in which case the user will be required to correct the interference at his own expense.

Appendix

B

Product Disposal

**CAUTION:**

Risk of explosion if battery is replaced by an incorrect type. Only certified engineers should replace the on-board battery.

Dispose of used batteries according to instructions and local regulations.

- Outside the European Union – If you wish to dispose of used electrical and electronic products outside the European Union, please contact your local authority so as to comply with the correct disposal method.
- Within the European Union – The device that produces less waste and is easier to recycle is classified as electronic device in terms of the European Directive 2012/19/EU (WEEE), and must not be disposed of as domestic garbage.

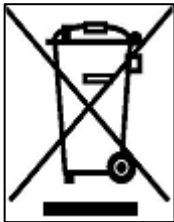

EU-wide legislation, as implemented in each Member State, requires that waste electrical and electronic products carrying the mark (left) must be disposed of separately from normal household waste. This includes monitors and electrical accessories, such as signal cables or power cords. When you need to dispose of your device, please follow the guidance of your local authority, or ask the shop where you purchased the product. The mark on electrical and electronic products only applies to the current European Union Member States.

Please follow the national guidelines for electrical and electronic product disposal.

Appendix

C

BIOS Options

Below is a list of BIOS configuration options in the BIOS chapter.

System Date [xx/xx/xx]	82
System Time [xx:xx:xx]	82
Security Device Support [Disable]	83
ACPI Sleep State [S3 (Suspend to RAM)]	84
Case Open Detection [Disabled]	85
Serial Port [Enabled]	86
Change Settings [IO=3F8h; IRQ=4;]	86
Serial Port [Enabled]	87
Change Settings [IO=2F8h; IRQ=3;]	87
Serial Port [Enabled]	87
Change Settings [IO=3E8h; IRQ=11;]	87
Serial Port [Enabled]	88
Change Settings [IO=2E8h; IRQ=11;]	88
Serial Port [Enabled]	89
Change Settings [IO=2D0h; IRQ=11;]	89
Transfer Mode [RS232]	90
Parallel Port [Enabled]	90
Device Mode [STD Printer Mode]	91
PC Health Status	91
CPU_FAN1 Smart Fan Control/SYS_FAN1 Smart Fan Control [Auto Mode]	93
Auto mode fan start/off temperature	93
Auto mode fan start PWM	93
Auto mode fan slope PWM	93
Wake system with Fixed Time [Disabled]	94
Console Redirection [Disabled]	95
Terminal Type [ANSI]	95
Bits per second [115200]	96
Data Bits [8]	96
Parity [None]	96
Stop Bits [1]	97
Legacy Serial Redirection Port [COM1]	97
Active Processor Cores [All]	98
Intel Virtualization Technology [Disabled]	99

IMBA-H110 ATX Motherboard

Intel(R) SpeedStep(tm) [Enabled].....	99
CPU C states [Disabled].....	99
Intel TXT(LT) Support [Disabled].....	99
SATA Controller(s) [Enabled]	100
SATA Mode Selection [AHCI].....	100
Hot Plug [Disabled].....	100
Legacy USB Support [Enabled].....	102
Auto Recovery Function [Disabled].....	103
VT-d [Disabled].....	105
Primary Display [Auto]	106
Internal Graphics [Enabled].....	106
DVMT Pre-Allocated [256M]	107
DVMT Total Gfx Mem [MAX].....	107
Primary IGFX Boot Display [VBIOS Default]	107
Enable Root Port [Enabled]	108
Max Link Speed [Auto]	108
Detect Non-Compliance Device [Disabled]	108
Restore AC Power Loss [Last State]	110
Power Saving Function(ERP) [Disabled].....	110
USB Power SW1 [+5V DUAL].....	111
USB Power SW2 [+5V DUAL].....	111
PCIe Speed [Auto].....	113
Detect Non-Compliance Device [Disabled]	113
HD Audio [Auto].....	114
Administrator Password	115
User Password	115
Bootup NumLock State [On].....	116
Quiet Boot [Enabled]	117
Launch PXE OpROM [Disabled].....	117
Option ROM Messages [Force BIOS].....	117
UEFI Boot [Disabled]	117
Save Changes and Reset	118
Discard Changes and Reset	118
Restore Defaults	118
Save as User Defaults	118

Restore User Defaults 118

Appendix

D

Terminology

AC '97	Audio Codec 97 (AC'97) refers to a codec standard developed by Intel® in 1997.
ACPI	Advanced Configuration and Power Interface (ACPI) is an OS-directed configuration, power management, and thermal management interface.
AHCI	Advanced Host Controller Interface (AHCI) is a SATA Host controller register-level interface.
ATA	The Advanced Technology Attachment (ATA) interface connects storage devices including hard disks and CD-ROM drives to a computer.
ARMD	An ATAPI Removable Media Device (ARMD) is any ATAPI device that supports removable media, besides CD and DVD drives.
ASKIR	Amplitude Shift Keyed Infrared (ASKIR) is a form of modulation that represents a digital signal by varying the amplitude (“volume”) of the signal. A low amplitude signal represents a binary 0, while a high amplitude signal represents a binary 1.
BIOS	The Basic Input/Output System (BIOS) is firmware that is first run when the computer is turned on and can be configured by the end user
CODEC	The Compressor-Decompressor (CODEC) encodes and decodes digital audio data on the system.
CMOS	Complimentary metal-oxide-conductor is an integrated circuit used in chips like static RAM and microprocessors.
COM	COM refers to serial ports. Serial ports offer serial communication to expansion devices. The serial port on a personal computer is usually a male DB-9 connector.
DAC	The Digital-to-Analog Converter (DAC) converts digital signals to analog signals.
DDR	Double Data Rate refers to a data bus transferring data on both the rising and falling edges of the clock signal.
DMA	Direct Memory Access (DMA) enables some peripheral devices to bypass the system processor and communicate directly with the system memory.

IMBA-H110 ATX Motherboard

DIMM	Dual Inline Memory Modules are a type of RAM that offer a 64-bit data bus and have separate electrical contacts on each side of the module.
DIO	The digital inputs and digital outputs are general control signals that control the on/off circuit of external devices or TTL devices. Data can be read or written to the selected address to enable the DIO functions.
EHCI	The Enhanced Host Controller Interface (EHCI) specification is a register-level interface description for USB 2.0 Host Controllers.
EIDE	Enhanced IDE (EIDE) is a newer IDE interface standard that has data transfer rates between 4.0 MBps and 16.6 MBps.
EIST	Enhanced Intel® SpeedStep Technology (EIST) allows users to modify the power consumption levels and processor performance through application software. The application software changes the bus-to-core frequency ratio and the processor core voltage.
FSB	The Front Side Bus (FSB) is the bi-directional communication channel between the processor and the Northbridge chipset.
GbE	Gigabit Ethernet (GbE) is an Ethernet version that transfers data at 1.0 Gbps and complies with the IEEE 802.3-2005 standard.
GPIO	General purpose input
HDD	Hard disk drive (HDD) is a type of magnetic, non-volatile computer storage device that stores digitally encoded data.
ICH	The Input/Output Control Hub (ICH) is an Intel® Southbridge chipset.
IrDA	Infrared Data Association (IrDA) specify infrared data transmission protocols used to enable electronic devices to wirelessly communicate with each other.
L1 Cache	The Level 1 Cache (L1 Cache) is a small memory cache built into the system processor.
L2 Cache	The Level 2 Cache (L2 Cache) is an external processor memory cache.
LCD	Liquid crystal display (LCD) is a flat, low-power display device that consists of two polarizing plates with a liquid crystal panel in between.

LVDS	Low-voltage differential signaling (LVDS) is a dual-wire, high-speed differential electrical signaling system commonly used to connect LCD displays to a computer.
POST	The Power-on Self Test (POST) is the pre-boot actions the system performs when the system is turned-on.
RAM	Random Access Memory (RAM) is volatile memory that loses data when power is lost. RAM has very fast data transfer rates compared to other storage like hard drives.
SATA	Serial ATA (SATA) is a serial communications bus designed for data transfers between storage devices and the computer chipsets. The SATA bus has transfer speeds up to 1.5 Gbps and the SATA II bus has data transfer speeds of up to 3.0 Gbps.
S.M.A.R.T	Self Monitoring Analysis and Reporting Technology (S.M.A.R.T) refers to automatic status checking technology implemented on hard disk drives.
UART	Universal Asynchronous Receiver-transmitter (UART) is responsible for asynchronous communications on the system and manages the system's serial communication (COM) ports.
UHCI	The Universal Host Controller Interface (UHCI) specification is a register-level interface description for USB 1.1 Host Controllers.
USB	The Universal Serial Bus (USB) is an external bus standard for interfacing devices. USB 1.1 supports 12Mbps data transfer rates and USB 2.0 supports 480Mbps data transfer rates.
VGA	The Video Graphics Array (VGA) is a graphics display system developed by IBM.

Appendix

E

Digital I/O Interface

E.1 Introduction

The DIO connector on the IMBA-H110 is interfaced to GPIO ports on the Super I/O chipset. The digital inputs and digital outputs are generally control signals that control the on/off circuit of external devices or TTL devices. Data can be read or written to the selected address to enable the DIO functions.



NOTE:

For further information, please refer to the datasheet for the Super I/O chipset.

The BIOS interrupt call **INT 15H** controls the digital I/O.

INT 15H:

AH – 6FH	
<u>Sub-function:</u>	
AL – 8	: Set the digital port as INPUT
AL	: Digital I/O input value

IMBA-H110 ATX Motherboard

E.2 Assembly Language Sample 1

```

MOV     AX, 6F08H      ;setting the digital port as input
INT     15H           ;

```

AL low byte = value

AH – 6FH
<u>Sub-function:</u>
AL – 9 : Set the digital port as OUTPUT
BL : Digital I/O input value

E.3 Assembly Language Sample 2

```

MOV     AX, 6F09H      ;setting the digital port as output
MOV     BL, 09H        ;digital value is 09H
INT     15H           ;

```

Digital Output is 1001b

Appendix

F

Watchdog Timer

IMBA-H110 ATX Motherboard



NOTE:

The following discussion applies to DOS environment. Contact IEI support or visit the IEI website for specific drivers for other operating systems.

The Watchdog Timer is provided to ensure that standalone systems can always recover from catastrophic conditions that cause the CPU to crash. This condition may have occurred by external EMIs or a software bug. When the CPU stops working correctly, Watchdog Timer either performs a hardware reset (cold boot) or a Non-Maskable Interrupt (NMI) to bring the system back to a known state.

A BIOS function call (INT 15H) is used to control the Watchdog Timer.

INT 15H:

AH – 6FH Sub-function:	
AL – 2:	Sets the Watchdog Timer's period.
BL:	Time-out value (Its unit-second is dependent on the item "Watchdog Timer unit select" in CMOS setup).

Table F-1: AH-6FH Sub-function

Call sub-function 2 to set the time-out period of Watchdog Timer first. If the time-out value is not zero, the Watchdog Timer starts counting down. When the timer value reaches zero, the system resets. To ensure that this reset condition does not occur, calling sub-function 2 must periodically refresh the Watchdog Timer. However, the watchdog timer is disabled if the time-out value is set to zero.

A tolerance of at least 10% must be maintained to avoid unknown routines within the operating system (DOS), such as disk I/O that can be very time-consuming.



NOTE:

When exiting a program it is necessary to disable the Watchdog Timer, otherwise the system resets.

EXAMPLE PROGRAM:

; INITIAL TIMER PERIOD COUNTER

;

W_LOOP:

;

```

MOV      AX, 6F02H      ;setting the time-out value
MOV      BL, 30         ;time-out value is 48 seconds
INT      15H
    
```

;

; ADD THE APPLICATION PROGRAM HERE

;

```

CMP      EXIT_AP, 1     ;is the application over?
JNE      W_LOOP        ;No, restart the application
    
```

```

MOV      AX, 6F02H     ;disable Watchdog Timer
MOV      BL, 0         ;
INT      15H
    
```

;

; EXIT ;

Appendix

G

Hazardous Materials Disclosure

The details provided in this appendix are to ensure that the product is compliant with the Peoples Republic of China (China) RoHS standards. The table below acknowledges the presences of small quantities of certain materials in the product, and is applicable to China RoHS only.

A label will be placed on each product to indicate the estimated “Environmentally Friendly Use Period” (EFUP). This is an estimate of the number of years that these substances would “not leak out or undergo abrupt change.” This product may contain replaceable sub-assemblies/components which have a shorter EFUP such as batteries and lamps. These components will be separately marked.

Please refer to below table.

Part Name	Toxic or Hazardous Substances and Elements					
	Lead (Pb)	Mercury (Hg)	Cadmium (Cd)	Hexavalent Chromium (CR(VI))	Polybrominated Biphenyls (PBB)	Polybrominated Diphenyl Ethers (PBDE)
Housing	O	O	O	O	O	O
Display	O	O	O	O	O	O
Printed Circuit Board	O	O	O	O	O	O
Metal Fasteners	O	O	O	O	O	O
Cable Assembly	O	O	O	O	O	O
Fan Assembly	O	O	O	O	O	O
Power Supply Assemblies	O	O	O	O	O	O
Battery	O	O	O	O	O	O

O: This toxic or hazardous substance is contained in all of the homogeneous materials for the part is below the limit requirement in SJ/T11363-2006 (now replaced by GB/T 26572-2011).

X: This toxic or hazardous substance is contained in at least one of the homogeneous materials for this part is above the limit requirement in SJ/T11363-2006 (now replaced by GB/T 26572-2011).

IMBA-H110 ATX Motherboard

此附件旨在确保本产品符合中国 RoHS 标准。以下表格标示此产品中某有毒物质的含量符合中国 RoHS 标准规定的限量要求。

本产品上会附有“环境友好使用期限”的标签，此期限是估算这些物质“不会有泄漏或突变”的年限。本产品可能包含有较短的环境友好使用期限的可替换元件，像是电池或灯管，这些元件将会单独标示出来。

部件名称	有毒有害物质或元素					
	铅 (Pb)	汞 (Hg)	镉 (Cd)	六价铬 (CR(VI))	多溴联苯 (PBB)	多溴二苯 醚 (PBDE)
壳体	○	○	○	○	○	○
显示	○	○	○	○	○	○
印刷电路板	○	○	○	○	○	○
金属螺帽	○	○	○	○	○	○
电缆组装	○	○	○	○	○	○
风扇组装	○	○	○	○	○	○
电力供应组装	○	○	○	○	○	○
电池	○	○	○	○	○	○

○: 表示该有毒有害物质在该部件所有物质材料中的含量均在 SJ/T 11363-2006 (现由 GB/T 26572-2011 取代) 标准规定的限量要求以下。

X: 表示该有毒有害物质至少在该部件的某一均质材料中的含量超出 SJ/T 11363-2006 (现由 GB/T 26572-2011 取代) 标准规定的限量要求。