

CV-112H/P1001E

12.1" TFT XGA 4:3 Touch Panel PC, with Intel® Atom™ E3845 Quad Core, 4x USB, 2x COM, 1x VGA, 1x DisplayPort and 2x Universal I/O Bracket



Key Features

- 12.1" TFT XGA 4:3 LCD with Resistive 5-wire / Projected Capacitive Touch
- Designed with Aluminum Die-Casting Front Frame
- Onboard Intel® Atom™ E3845 Processor Quad Core, 1.91GHz
- 1x DDR3L SO-DIMM max. up to 8GB
- 1x 2.5" SATA HDD Bay, 1x CFast Card and 1x SIM Card Socket
- 2x LAN, 4x USB, 2x COM, 1x VGA, 1x DisplayPort, 4x DI/4x DO
- 1x Mini-PCle Expansion Socket
- 2x Universal I/O Brackets
- IP65 Compliant Front Panel
- Supports Panel / VESA / Rack Mounting
- Convertible Display System (CDS) Supported
- Built-in Two 2W Internal Speakers

»» Overview

The 12.1" all-in-one panel PC offers LED backlight LCD with resolution up to 1024x768 (XGA) and 500 nits brightness. CV-112H/P1001E features flat surface and IP65 dust/waterproof front panel. In addition, designed with aluminum die-casting front frame with rugged body structure that can be able to apply in industrial applications. CV-112H/P1001E supports Convertible Display System (CDS) technology which makes it more flexible in system maintaining and upgrading. CV-112H/P1001E carries single touch function with resistive 5-wire touch screen. By incorporating with Intel® Atom™ E3845 processor and DDR3L memory, CV-112H/P1001E offers extensive I/O including 4x USB, 2x RS-232/422/485, 1x VGA, 1x DisplayPort, 4x DI / 4x DO and 2x Universal I/O Bracket.

CV-112H/P1001E supports 3G and WLAN via 2x GbE and 1x Mini-PCle slot. Furthermore, they are 3 types of storage devices including 2.5" SATA HDD, CFast and SIM card. The accessible design of these storage devices allow quick data access and easy maintenance. Supporting wide range power DC input from 9 ~ 48VDC, CV-112H/P1001E can be deployed and powered for various industrial applications.

»» Specifications

Display

- LCD Size: 12.1" (4:3)
- Max. Resolution: 1024 x 768
- Brightness (cd/m2): 500
- Contrast Ratio: 700 : 1
- LCD Color: 16.2M
- Pixel Pitch (mm): 0.24 (H) x 0.24 (V)
- Viewing Angle (H-V): 160 / 160
- Backlight MTBF: 30,000 hrs (LED Backlight)

Touch

- Resistive 5-wire Touch for CV-112HR/P1001E Only
- Projected Capacitive Touch for CV-112HC/P1001E Only

Processor

- Onboard Intel® Atom™ Processor E3845 Quad Core, 1.91 GHz with AMI 64Mbit SPI BIOS

Memory

- 1x 204-Pin SO-DIMM DDR3L 1066 / 1333MHz (un-buffered and non-ECC), max. up to 8GB

Storage

- 1x External 2.5" SATA HDD Bay
- 1x External CFast Socket
- 1x External SIM Card Socket

External I/O Interface

- 1x VGA
- 1x DisplayPort
- 1x USB 3.0
- 3x USB 2.0
- 2 x Intel® i210-AT GbE LAN Port (Support Wake-on-LAN and PXE)
- 2x DB9 for COM1~2 (Support RS-232/422/485 with Auto Flow Control)
- 1x 4 Isolated DI & 4 Isolated DO Port
- 1x Line-out
- 1x Mic-in
- 1x Power Switch
- 1x Reset Button
- 1x AT/ATX Switch

Digital Input & Output

- 4x Digital Input (Source Type)
 - Input Voltage (Dry Contact):
 - Logic 0: Close to GND
 - Logic 1: Open
 - Input Voltage:
 - Logic 0: -3V (Min/DI to COM+)
- 4x Digital Output
 - Supply Voltage: 5-30VDC
 - Sink Current: 580mA Max.
 - DIO Max.: 30V

Expansion

- 1x Full-size Mini PCIe Socket for Wi-Fi / GSM / Expansion Module
- 2x Universal I/O Brackets

Watchdog Timer

- Software Programmable Supports 256 Levels System Reset

Power Requirement

- Support AT, ATX Mode
- 1x 3-pin Terminal Block Connector with Power Input 9-48VDC
- 1x Optional AC/DC 12V/5A, 60W Power Adapter

Environment

- Operating Temperature: Ambient with air flow: -20°C to 70°C (with Industrial Grade Peripherals)
- Storage Temperature: -30°C to 80°C
- Relative Humidity: 10%~90% (non-condensing)
- IP Level: IP 65 Compliant Front Panel

Physical

- Dimension (WxDxH): 344.97 x 265.3 x 88.35 mm
- Weight: 4.7 kg
- Construction Front Panel: Die-Casting Flat Surface
- Mounting: Panel / VESA / *Rack Mounting (*with optional mounting kit)

Operating System

- Windows® 10
- Windows® 8
- Windows® Embedded 8 Standard
- Windows® 7
- Windows® Embedded Standard 7
- Linux® Ubuntu 14.04

Certification

- CE
- FCC Class A

»» External I/O Mechanical Layout

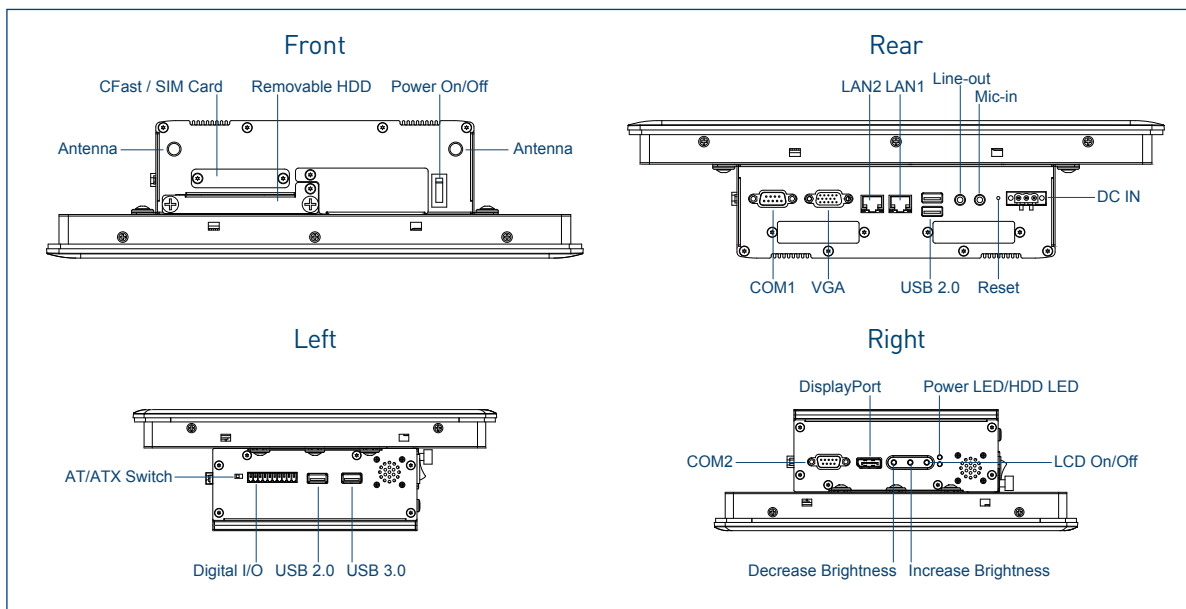

»» Dimensions

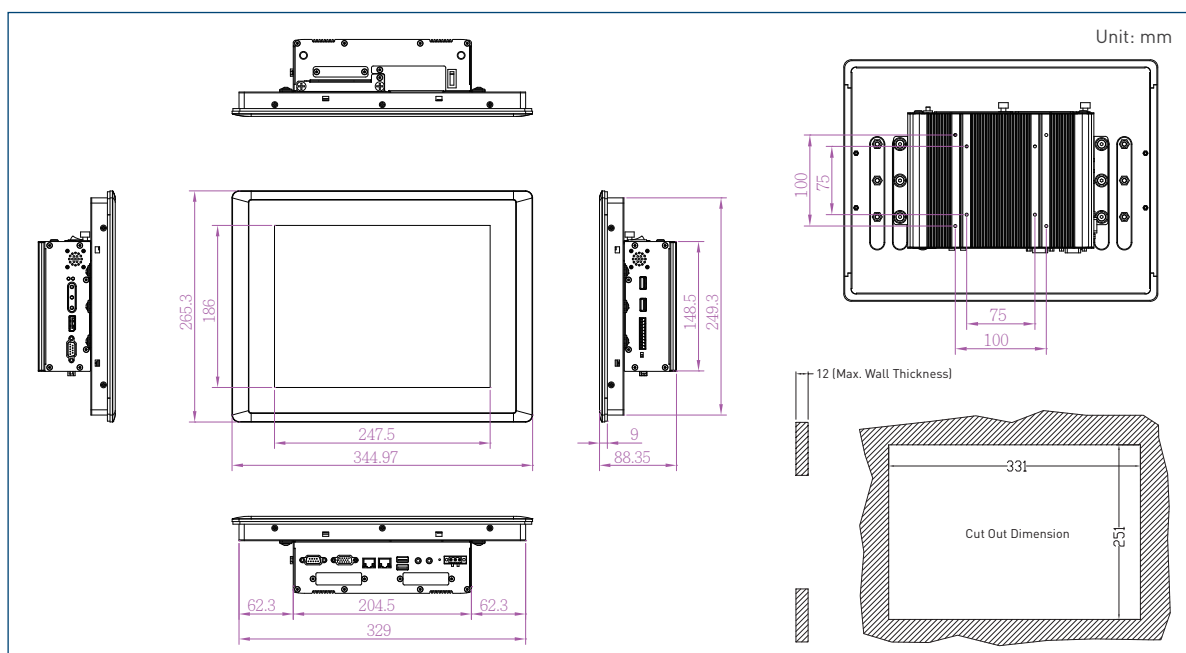

»» Ordering Information

Available Models

Model No.	Product Description
CV-112HR/P1001E	12.1" TFT XGA 4:3 Panel PC with Resistive 5-wire Touch , with Intel® Atom™ E3845 Quad Core, 4x USB, 2x COM, 1x VGA, 1x DisplayPort and 2x Universal I/O Bracket
CV-112HC/P1001E	12.1" TFT XGA 4:3 Panel PC with Projected Capacitive Touch , with Intel® Atom™ E3845 Quad Core, 4x USB, 2x COM, 1x VGA, 1x DisplayPort and 2x Universal I/O Bracket

Package Checklist

CV-112H/P1001E

- CV-112H/P1001E Panel PC x 1
- Panel Mounting Kit x 4
- Utility DVD Driver x 1
- DIO Terminal Block Connector x 1
- Power Terminal Block Connector x 1
- HDD Screw Pack x 1
- Mini PCIe Screw Pack x 1

Optional Accessories

Model No.	Description
GST60A12-CIN	Adapter AC/DC 12V 5A 60W, GST60A12-CIN, wide temp [-30°C ~ +70°C], level VI
SL2-SL3	US 2 heads power cord, US B type to IEC C13, SVT 18AWG/3C Black 1.8M SL-2+SL-3
SL6-SL3	EU 2 heads power cord, EU G type to IEC C13, H05VV-F 0.75mm2/3G Black 1.8M SL-6+SL-3
QP026-SL3	UK 2 heads power cord, UK I type to IEC C13, H05VV-F 0.75mm2/3G Black 1.8M QP026+SL-3
URM01	Universal 19" Rack Mount Kit for Industrial Panel PC & Industrial Monitor