

CV-110H/P1001

10.4" TFT XGA 4:3 Panel PC with Resistive 5-wire / Projected Capacitive Touch, w/ Intel® Atom™ E3845 Quad Core, 4x USB, 2x COM, 1x VGA and 1x DisplayPort



Key Features

- 10.4" TFT XGA 4:3 LCD with Resistive 5-wire / Projected Capacitive Touch
- Designed with Aluminum Die-Cast Front Frame
- Onboard Intel® Atom™ E3845 Processor Quad Core, 1.91GHz
- 1x DDR3L SO-DIMM Max. Up to 4GB
- 1x 2.5" SATA HDD Bay, 1x CFast Card and 1x SIM Card Socket
- 2x LAN, 4x USB, 2x COM, 1x VGA, 1x DisplayPort, 4x DI/4x DO
- 1x Mini-PCIe Expansion Socket
- IP65 Compliant Front Panel
- Supports Panel / VESA / Rack Mounting
- Convertible Display System (CDS) Supported
- Built-in Two 2W Internal Speakers

»» Overview

The 10.4" all-in-one panel PC offers LED backlight LCD with resolution up to 1024 x 768 (XGA) and 400 nits brightness. CV-110H/P1001 features flat surface and IP65 dust/waterproof front panel. In addition, designed with aluminum die-cast front frame with rugged body structure that can be able to apply in industrial applications. CV-110H/P1001 supports Convertible Display System (CDS) technology which makes it more flexible in system maintaining and upgrading. CV-110H/P1001 carries single touch function with resistive 5-wire touch screen or multi-touch function with projected capacitive touch screen. By incorporating with Intel® Atom™ E3845 processor and DDR3L memory, CV-110H/P1001 offers extensive I/O including 4x USB, 2x RS232/422/485, 1x VGA, 1x Display-Port and 4 DI/ 4DO.

CV-110H/P1001 supports 3G and WLAN via 2x GbE and 1x Mini-PCIe slot. Furthermore, they are 3 types of storage devices including 2.5" SATA HDD, CFast and SIM card. The accessible design of these storage devices allow quick data access and easy maintenance. Supporting wide range power DC input from 9 ~ 48VDC, CV-110/P1001 can be deployed and powered for various industrial applications.

»» Specifications

Display

- LCD Size: 10.4" (4:3)
- Max. Resolution: 1024 x 768
- Brightness (cd/m2): 400
- Contrast Ratio: 1400 : 1
- LCD Color: 16.2M
- Pixel Pitch (mm): 0.2055 (H) x 0.2055 (V)
- Viewing Angle (H-V): 178 / 178
- Backlight MTBF: 50000 hrs (LED Backlight)

Touch

- Resistive 5-wire Touch for CV-110HR/P1001 Only
- Projected Capacitive Touch for CV-110HC/P1001 Only

Processor System

- Onboard Intel® Atom™ Processor E3845 Quad Core, 1.91 GHz with AMI 64Mbit SPI BIOS

Memory

- 1x 204-Pin SO-DIMM DDR3L 1066 / 1333MHz (un-buffered and non-ECC), max. up to 4GB

Ethernet

- 2 x Intel® i210-AT GbE LAN Port, Support Wake-on-LAN and PXE

Storage

- 1x External 2.5" SATA HDD Bay
- 1x External CFast Socket
- 1x External SIM Card Socket

I/O Ports

- 1x VGA
- 1x DisplayPort
- 1x USB 3.0
- 3x USB 2.0
- 2x DB9 for COM1~2 (Support RS232/422/485 with Auto Flow Control)
- 1x Line-out
- 1x Mic-in
- 1x Power Switch
- 1x Reset Button
- 1x AT/ATX Switch

Digital Input & Output

- 4x Digital Input (Source Type)
 - Input Voltage (Dry Contact):
 - Logic 0: Close to GND
 - Logic 1: Open
 - Input Voltage:
 - Logic 0: 3V max.
 - Logic 1: 5V min. (DI to COM-)
- 4x Digital Output
 - Supply Voltage: 5~30VDC
 - Sink Current: 200 mA Max. Per Channel

Expansion

- 1x Full-size Mini-PCIe Socket for Wi-Fi / GSM / Expansion Module

Other Features

- Watchdog Timer: Software Programmable Supports 256 Levels System Reset
- Audio: AMP 2W + 2W (Internal Speaker)
- OSD Function: LCD On/Off, Brightness Up/Down

Power

- Support AT, ATX Mode
- 1x 3-pin Terminal Block Connector with Power Input 9~48VDC
- 1x Optional AC/DC 12V/5A, 60W Power Adapter

Environment

- Operating Temperature: -20°C to 70°C (CV-110HR/P1001)
- Operating Temperature: -10°C to 70°C (CV-110HC/P1001) (Ambient with air flow and with Industrial Grade Peripherals)
- Storage Temperature: -30°C to 80°C
- Relative Humidity: 80% RH @ 40°C (Non-Condensing)
- IP Level: IP 65 Compliant Front Panel

Physical

- Dimension (WxDxH, mm): 295 x 227.3 x 65 mm
- Weight: 3.58 kg
- Construction Front Panel: Die-Cast Flat Surface
- Mounting: Panel / VESA / *Rack Mounting (*with optional mounting kit)

Operating System

- Windows® 10 / 8.1 / 7
- Linux® Kernel 3.x

Certification

- CE
- FCC Class A

»» Mechanical Layout

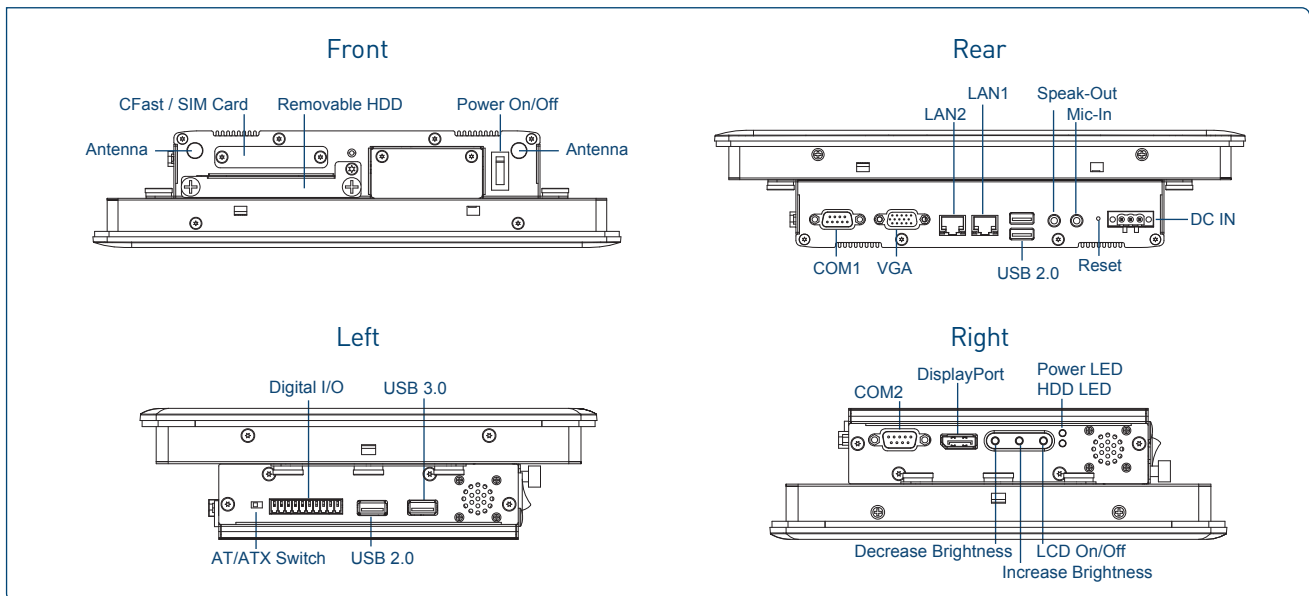

»» Dimensions

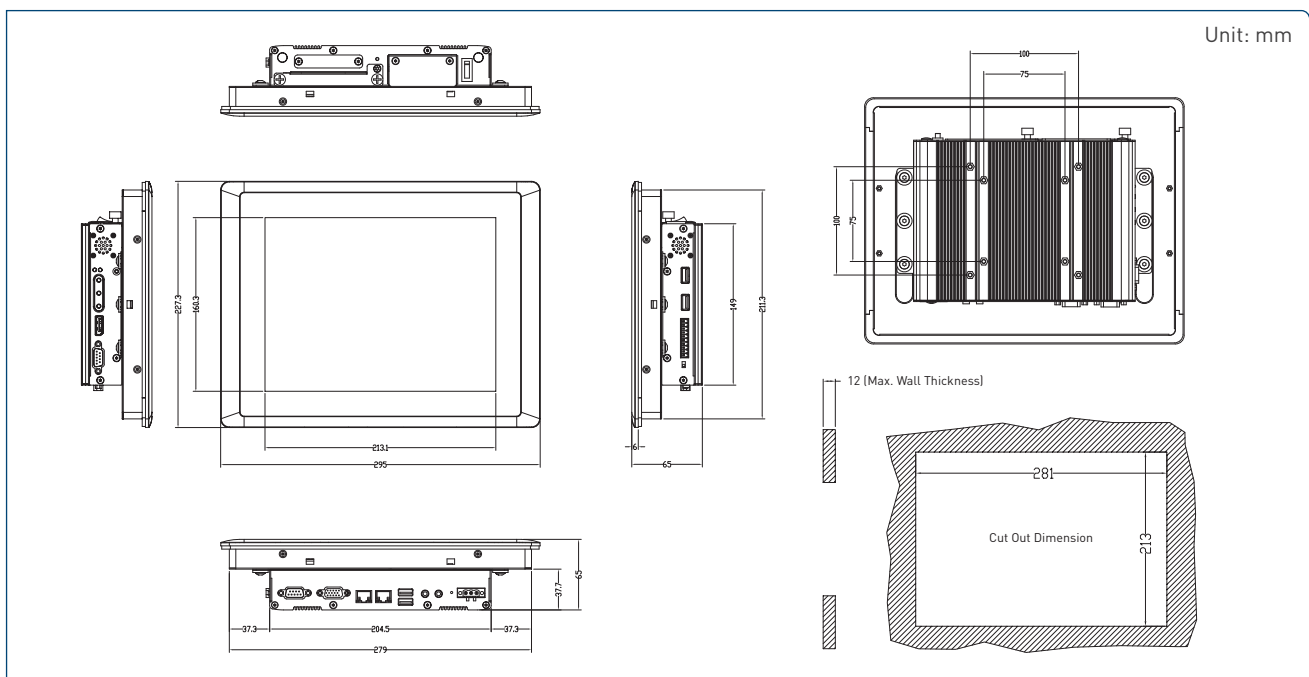

»» Ordering Information

Available Models

Model No.	Product Description
CV-110HR/P1001	10.4" TFT XGA 4:3 Panel PC with Resistive 5-wire Touch , w/ Intel® Atom™ E3845 Quad Core, 4x USB, 2x COM, 1x VGA and 1x DisplayPort
CV-110HC/P1001	10.4" TFT XGA 4:3 Panel PC with Projected Capacitive Touch , w/ Intel® Atom™ E3845 Quad Core, 4x USB, 2x COM, 1x VGA and 1x DisplayPort

Package Checklist

CV-110H/P1001

- Panel PC x 1
- Panel Mounting Kit x 1
- Utility DVD Driver x 1
- DIO Terminal Block Connector x 1
- Power Terminal Block Connector x 1
- Screw Pack x 1

Optional Accessories

Model No.	Description
GST60A12-CIN	Adapter AC/DC 12V 5A 60W, GST60A12-CIN, wide temp [-30°C ~ +70°C], level VI
SL2-SL3	US 2 heads power cord, US B type to IEC C13, SVT 18AWG/3C Black 1.8M SL-2+SL-3
SL6-SL3	EU 2 heads power cord, EU G type to IEC C13, H05VV-F 0.75mm2/3G Black 1.8M SL-6+SL-3
QP026-SL3	UK 2 heads power cord, UK I type to IEC C13, H05VV-F 0.75mm2/3G Black 1.8M QP026+SL-3
URM01	Universal 19" Rack Mount Kit for Industrial Panel PC & Industrial Monitor