

# DEVA

## COM.0 Type 7 Evaluation Baseboard

Rev. A.0 IT version

### Content

- SH01\_MAIN\_PAGE
- SH02\_Blockdiagram
- SH03\_COM\_EXPRESS\_AB
- SH04\_COM\_EXPRESS\_CD
- SH05\_SATA
- SH06\_USB\_3.0
- SH07\_Gbe\_LAN
- SH08\_PCIE\_CLK
- SH09\_PCIEx16
- SH10\_PCIEx8\_X4(0/1)
- SH11\_VGA
- SH12\_BMC(PCIE/DDR/I2C)
- SH13\_BMC(UART/SPI/MAC)
- SH14\_BMC(USB/ADC/DAC)
- SH15\_BMC(POWER)
- SH16\_DDR4\_256Mx16
- SH17\_RGMII
- SH18\_10Gbe\_PHY\_0/1
- SH19\_10Gbe\_SFP+\_0/1
- SH20\_10Gbe\_PHY\_2/3
- SH21\_10Gbe\_SFP+\_2/3
- SH22\_UART
- SH23\_SPI\_I2C\_TPM
- SH24\_SPK\_FEATURE\_FAN\_RTC\_BTN
- SH25\_POSTCODE
- SH26\_POWER
- SH27\_DCDC\_5V\_3V3
- SH28\_DCDC\_1V15\_2V5\_1V2\_1V8
- SH29\_DCDC\_0V9\_1V8
- SH30\_Power/Clock\_Delivery
- SH31\_History

P28 PDEVALA0	P27 065421A conga-X7/EVAL/industrial	<b>Label &amp; Packaging</b>	
P1 MESDLABEL74x37	P2 MESDBAG356x457	P3 ML0002	
<b>Documentation</b>			
SOP Label Assembly DEVA SOP1		DEVASA0_IT - Schematic DEVA_IT A.0 SCHEMATIC AS PDF1	

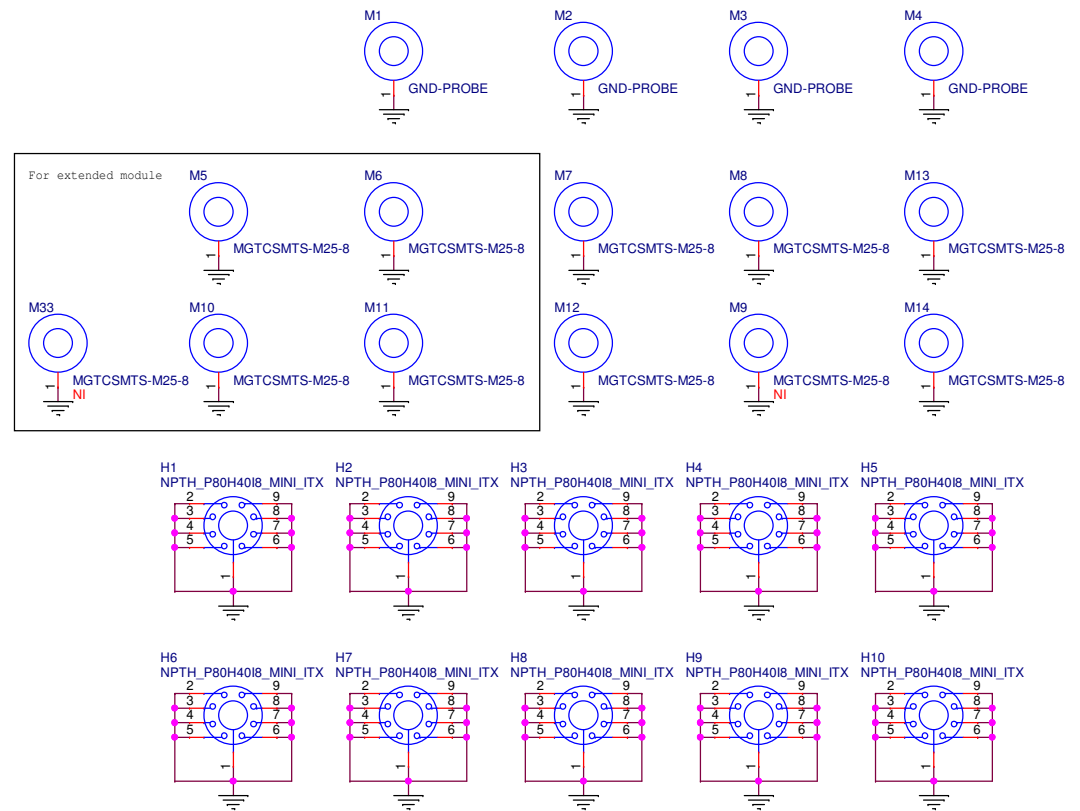

Congatec AG Auwiesenstrasse 5 D-94469 Deggendorf Germany			
<b>Title</b> Main Page			
<b>Size</b> B	<b>Document Number</b> DEVA_A0	<b>Created</b> <OrgAddr4>	<b>Rev</b> A.0
<b>Date:</b>	Thursday, May 18, 2017	<b>Sheet</b>	1 of 30

internal connector  
 external connector  
 chip

# DEVA System Block Diagram

## IT version

### SYSTEM SUPPLY

DC connector (12V)  
 ATX connector (12V/5V/3.3V/5VSB)  
 RTC battery

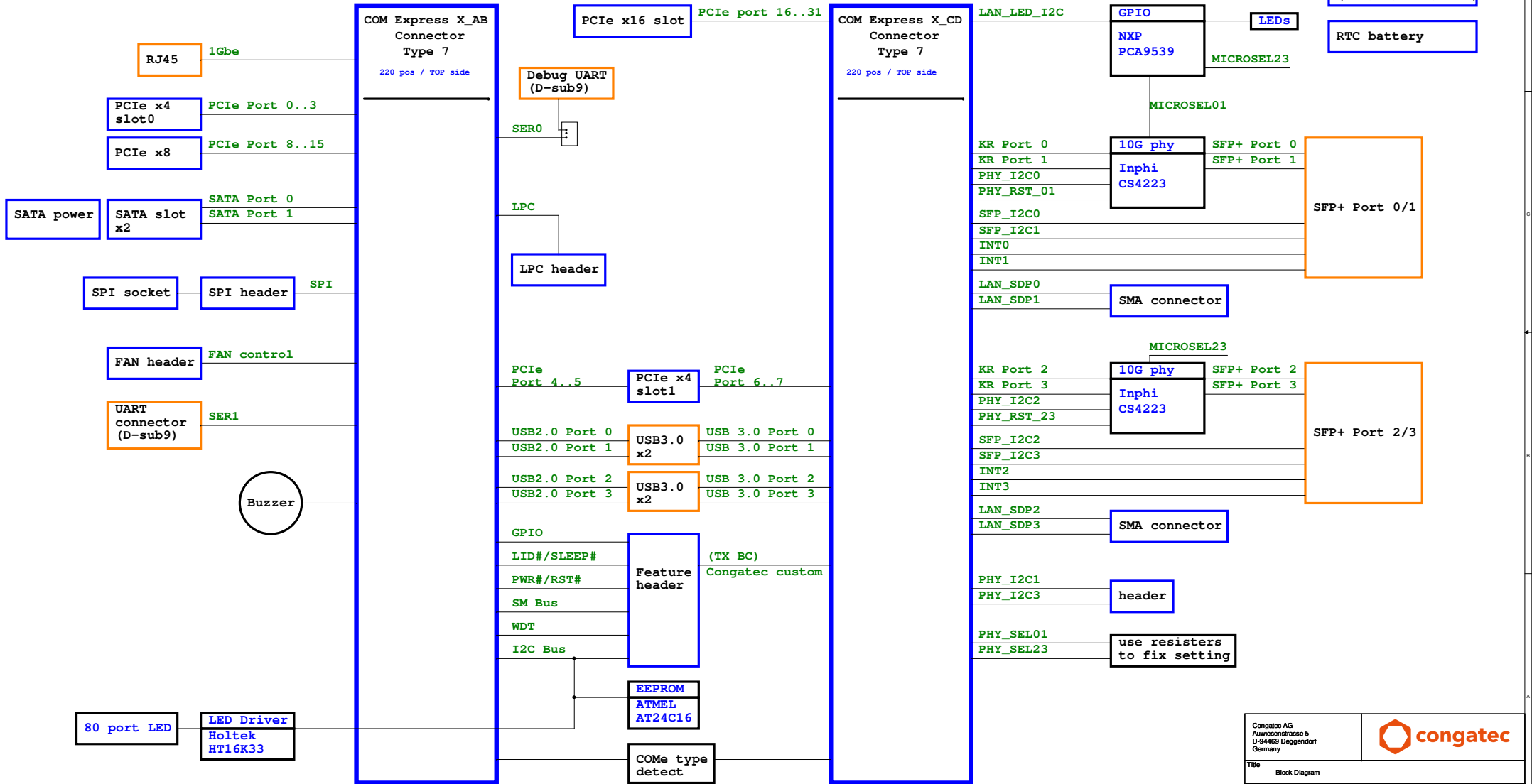

# SH03\_COM\_EXPRESS\_AB

check footprint

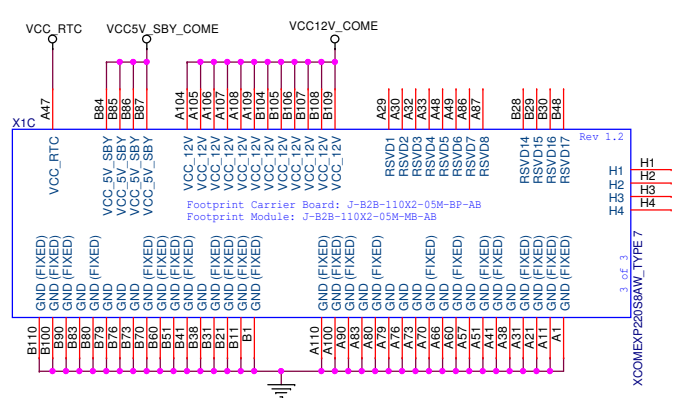
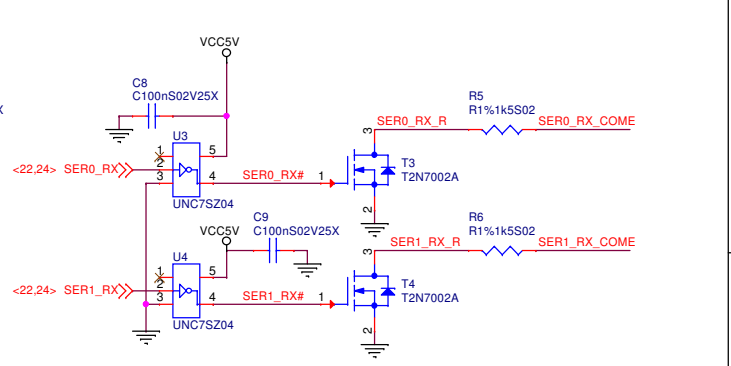
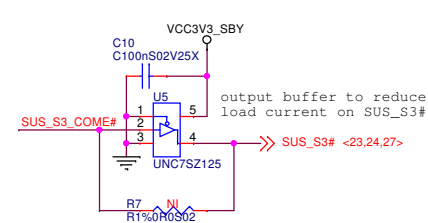
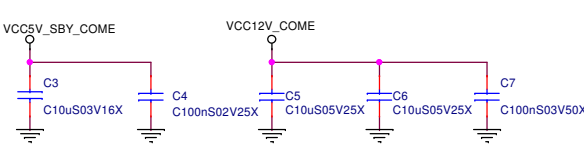
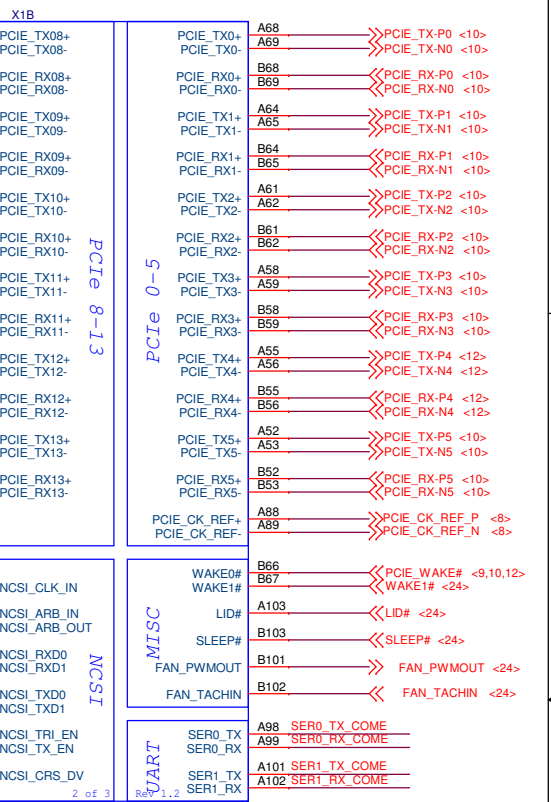
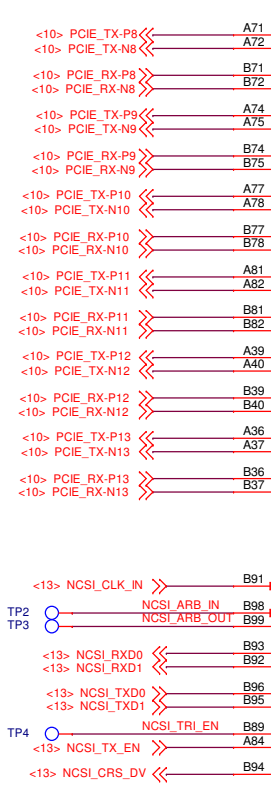
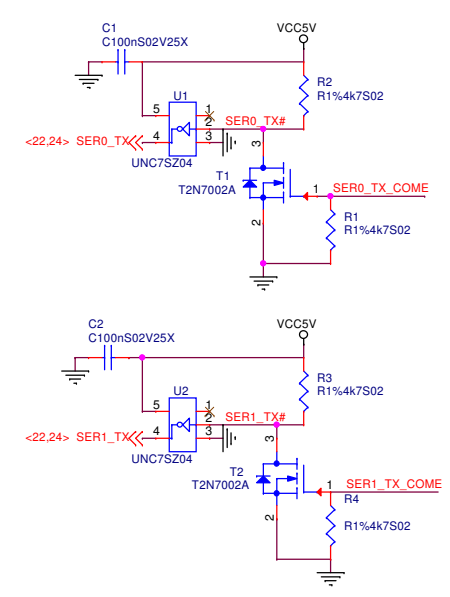
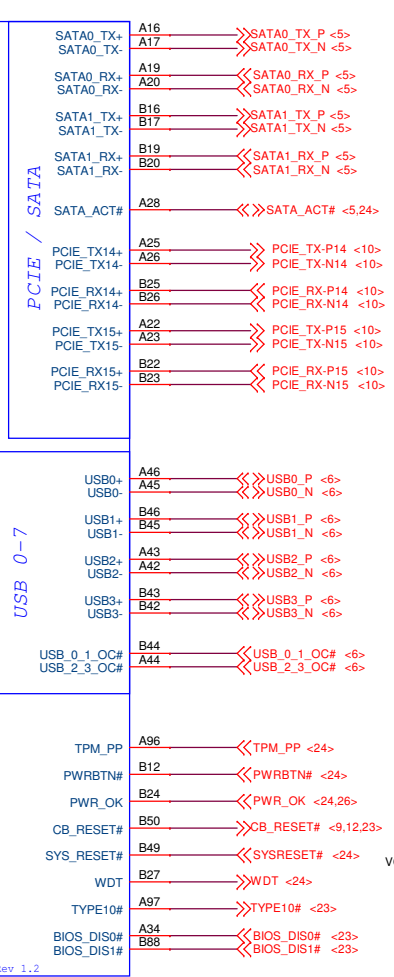
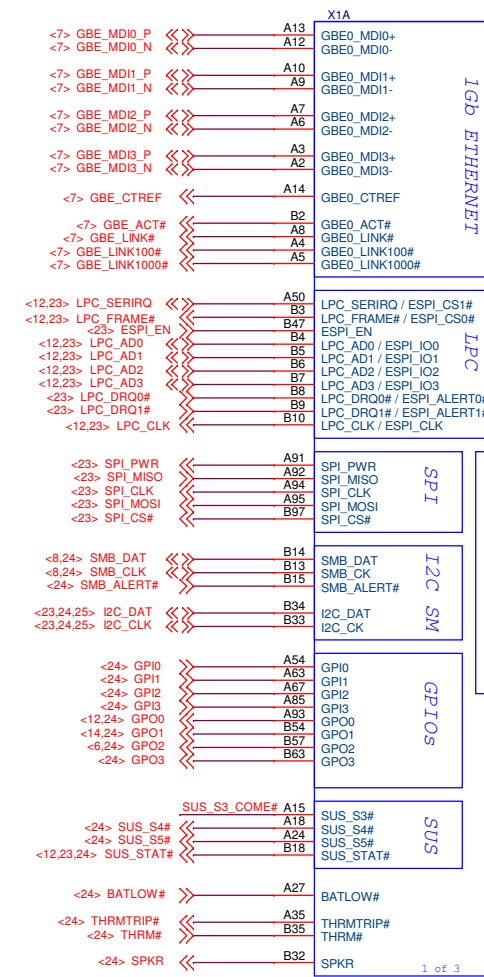

Congatec AG  
 Auwiesenstrasse 5  
 D-94469 Deggendorf  
 Germany

Title: COM Express Type 7 AB connector

Size A3 | Document Number DEVA\_A0 | Created <OrgAddr> | Rev A.0

Date: Sunday, April 23, 2017 | Sheet 3 of 30

# SH04\_COM\_EXPRESS\_CD

GPIO OD?

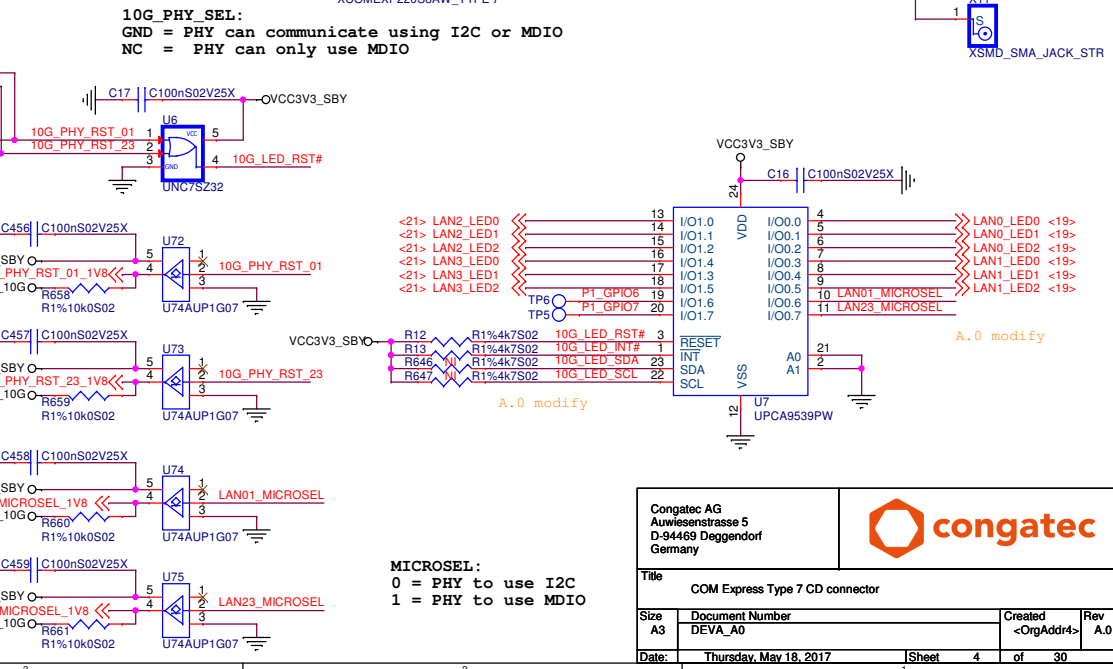
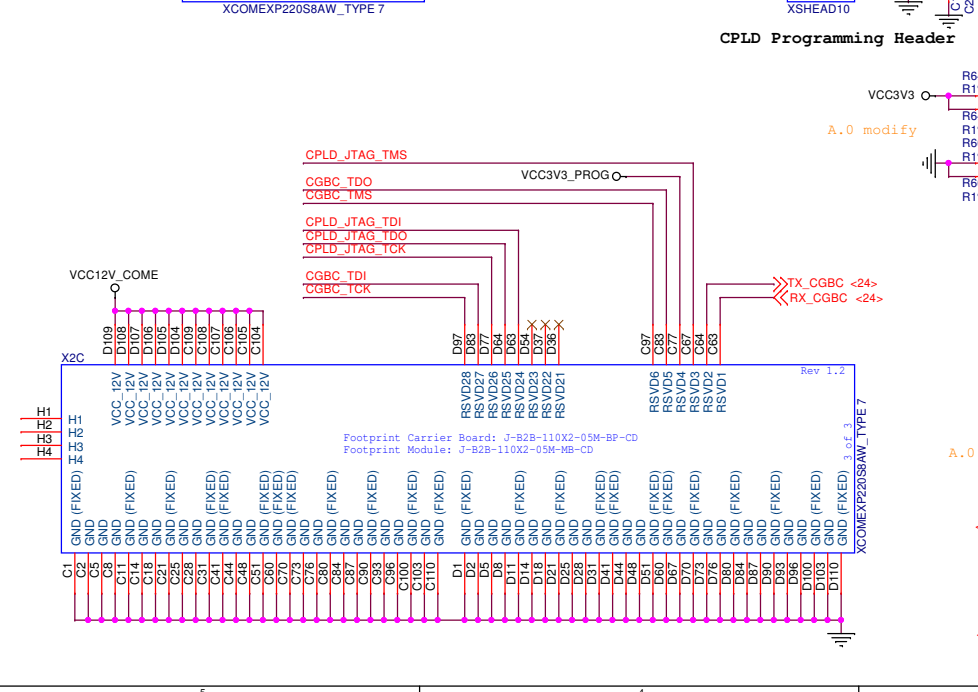
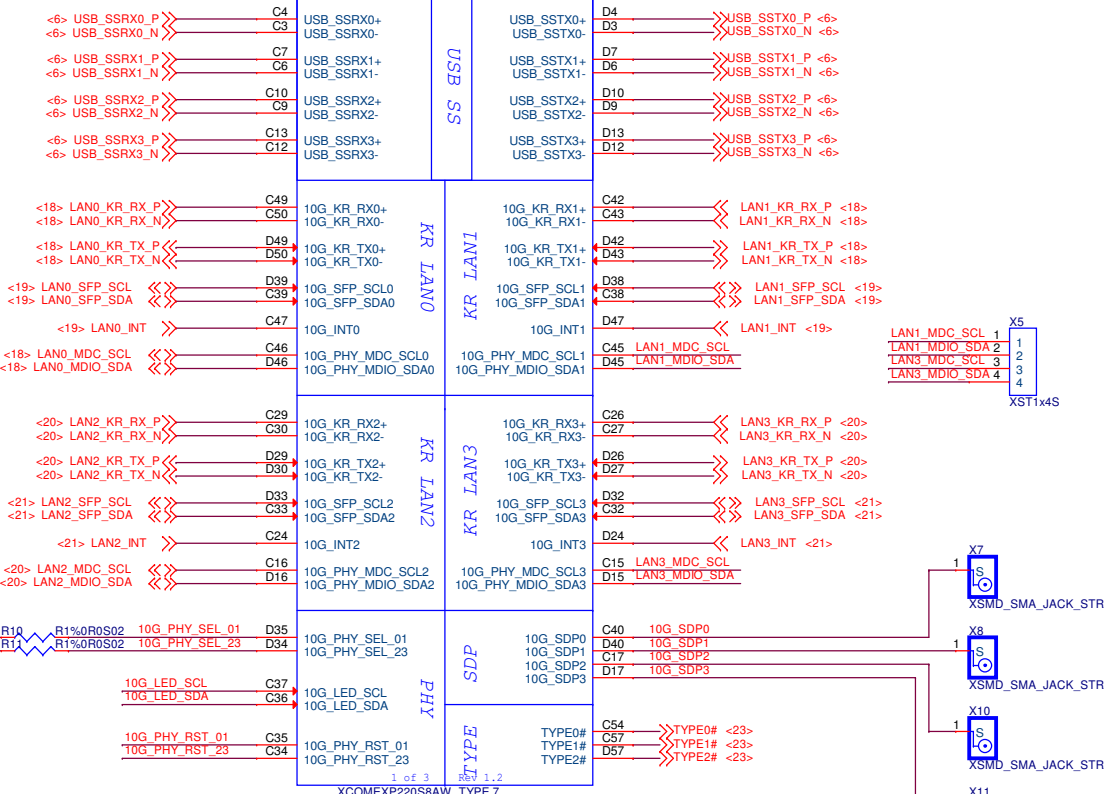
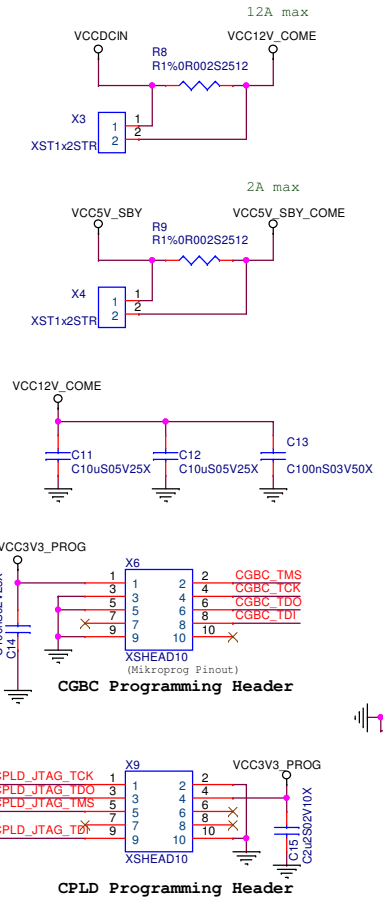
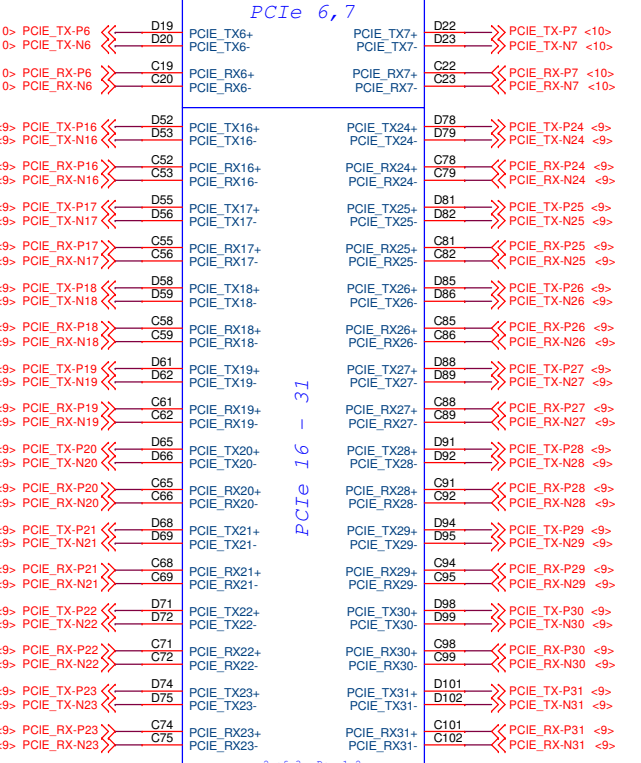

**Congatec AG**  
Auwiesenstrasse 5  
D-94468 Deggendorf  
Germany

**congatec**

Title: COM Express Type 7 CD connector

Size A3	Document Number DEVA_A0	Created -OrgAddr-	Rev A.0
---------	-------------------------	-------------------	---------

Date: Thursday, May 18, 2017 | Sheet 4 of 30

SATA

SATA Power

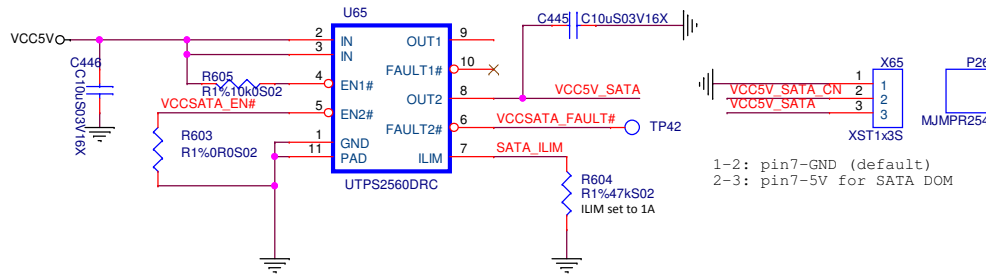
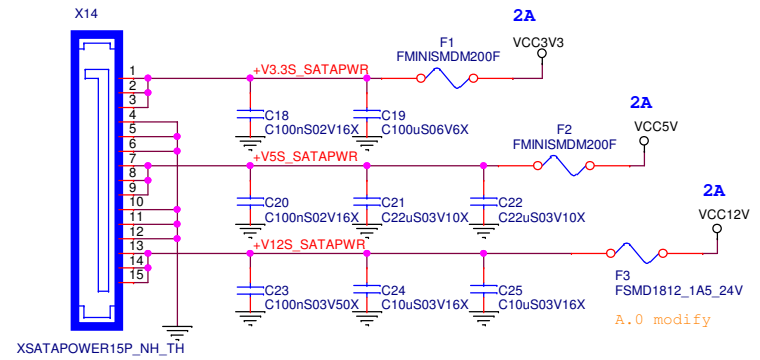
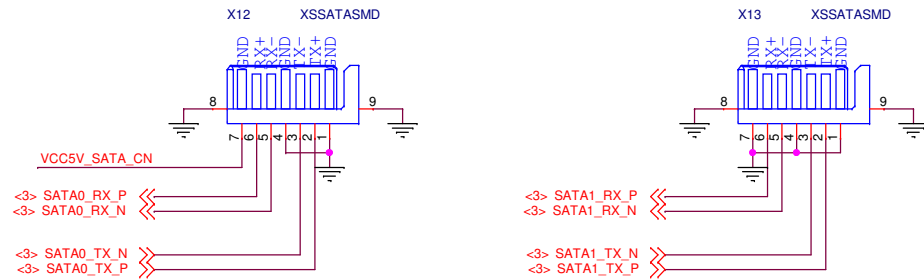

1-2: pin7-GND (default)  
 2-3: pin7-5V for SATA DOM

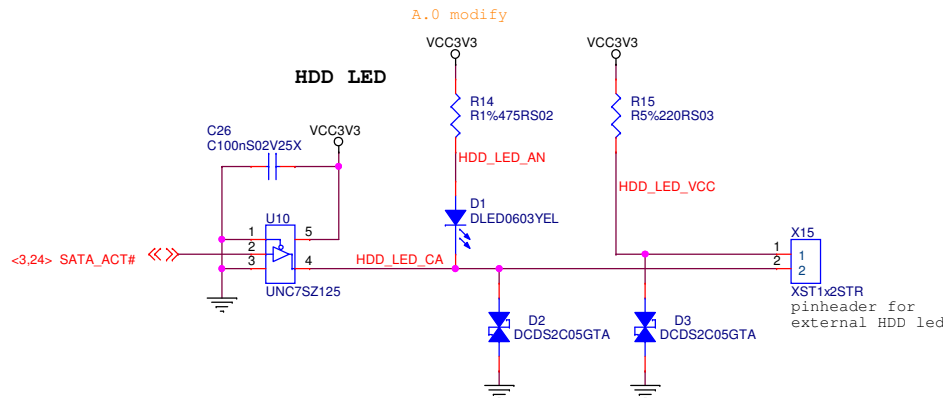

Congatec AG Auwiesenstrasse 5 D-94469 Deggendorf Germany			
Title: SATA			
Size B	Document Number: DEVA_A0	Created <OrgAddr4>	Rev A.0
Date: Sunday, April 23, 2017	Sheet 5	of 30	

use 3-pad layout placement

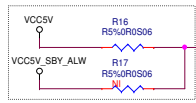

1.8A

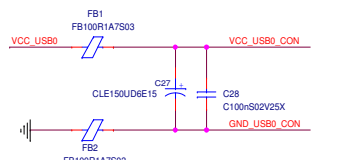
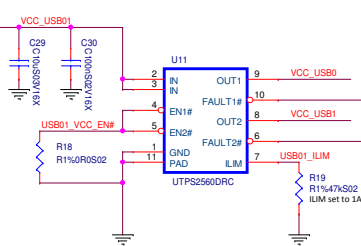

USB 3.0 spec. requires low ESR cap (>= 120 uF) directly connected to I/O connector

USB 3.0 0/1

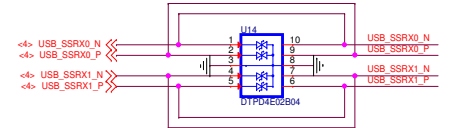
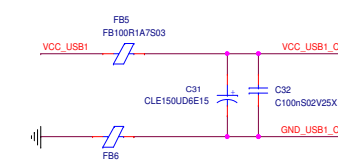
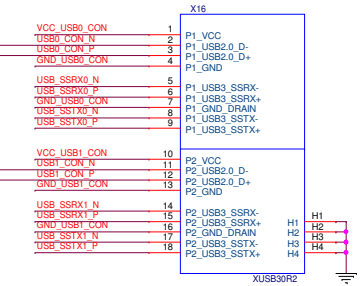

Layout note for ESD parts

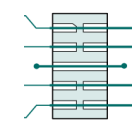

use 3-pad layout placement

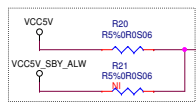

1.8A

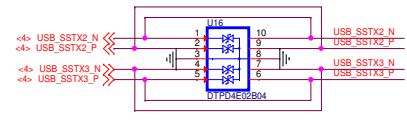
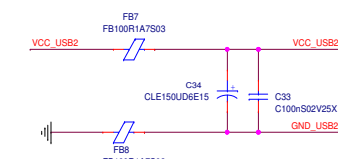
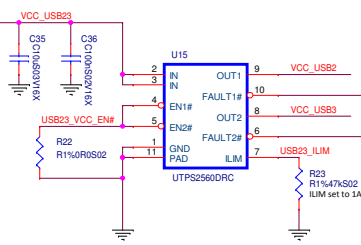

USB 3.0 2/3

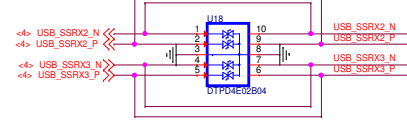
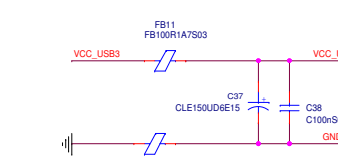
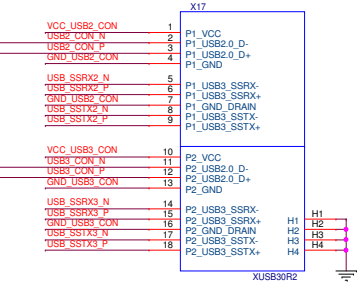

USB2.0 P3 MUX

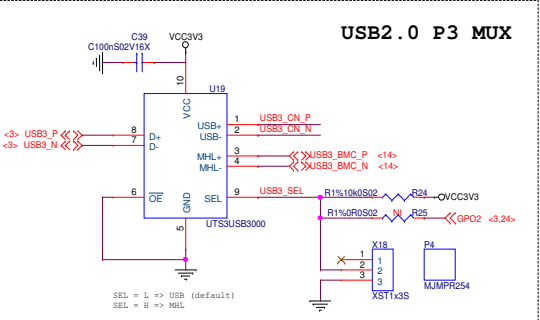

Congatec AG Auenroterstrasse 5 D-94469 Deggendorf Germany			
Title: USB 3.0			
Size C	Document Number	Created	Rev
	DEVA_A0	<OrigAuth>	A.0
Date:	Sunday, April 23, 2017	Sheet	6 of 30

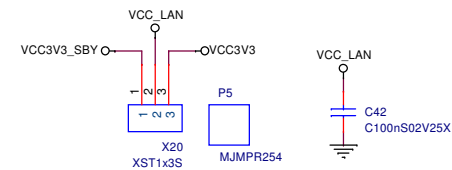
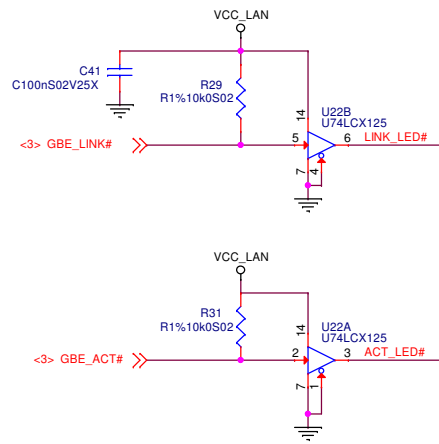
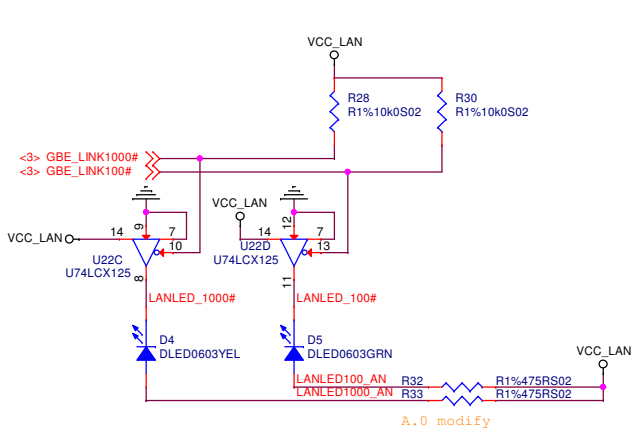
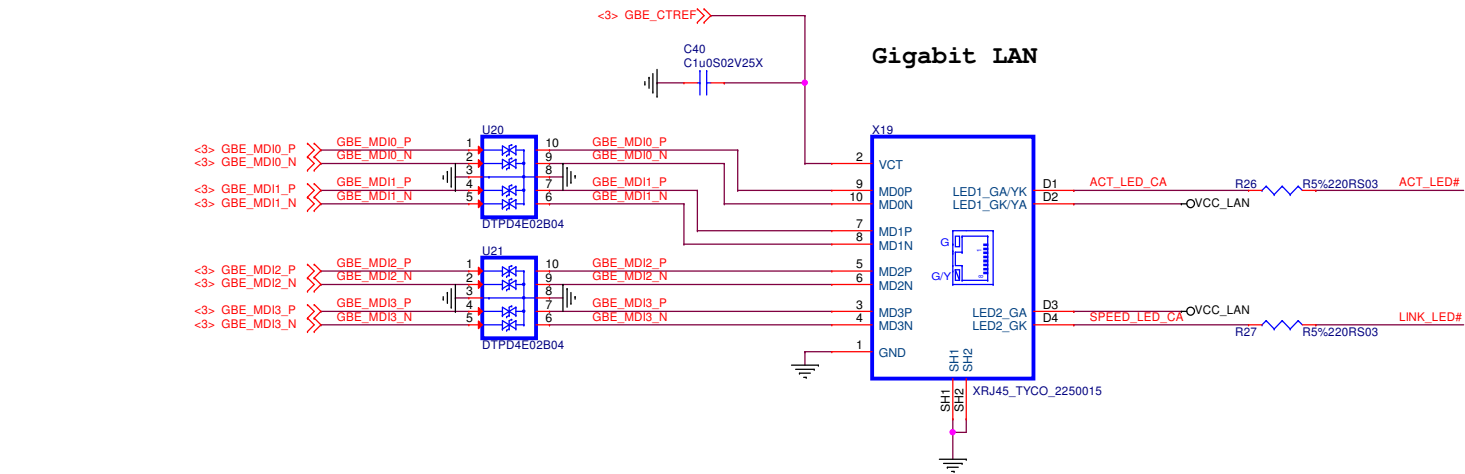

set jumper 1-2 if LAN Controller is powered from standby voltage (default)  
set jumper 2-3 if LAN Controller is powered from S0 voltage

# SH08\_PCIE\_CLK

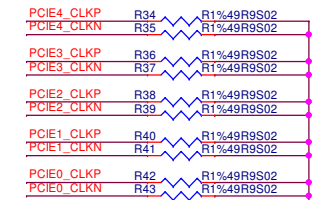
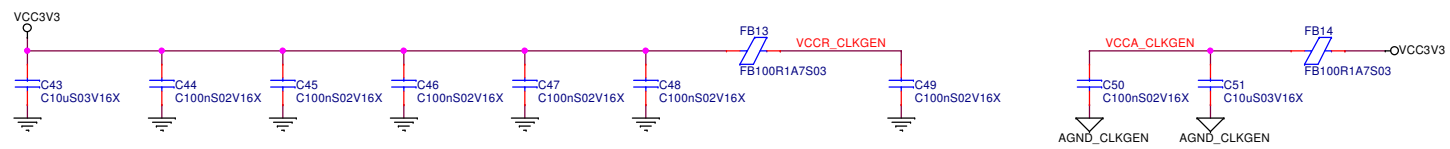

LOW ... DA/DB  
MID ... DC/DD  
HIGH ... D8/D9

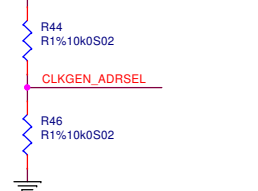

determining SRC  
output freq  
0 = SRC/2  
1 = SRC

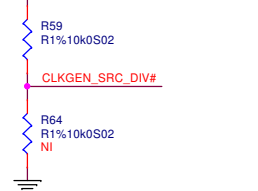

LOW ... Bypass  
MID ... PLL 100M Hi BW  
HIGH ... PLL 100M Low BW

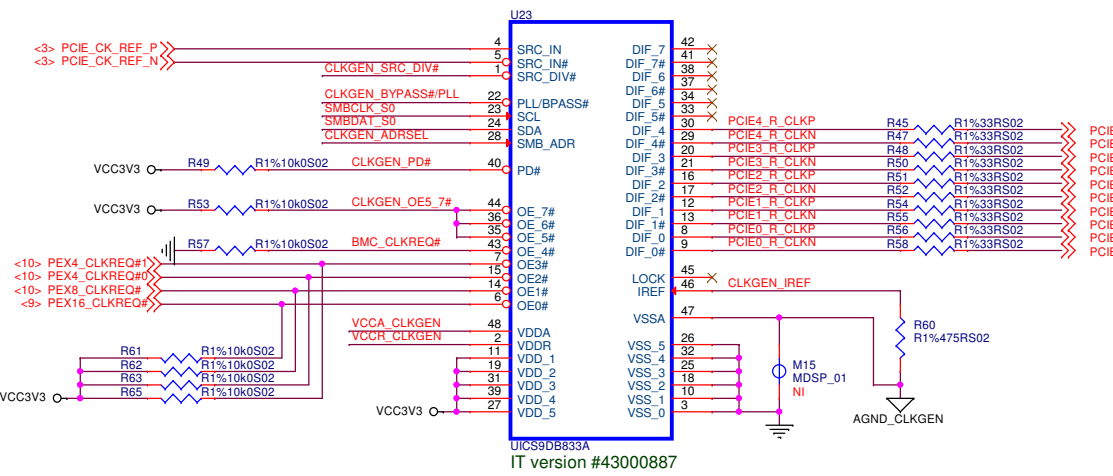
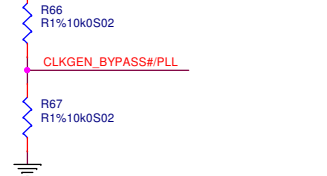

**BMC VGA**  
PCIE x4 P1 (12-15)  
PCIE x4 P0 (8-11)  
PCIE x8 (0-7)  
PCIE x16 (16-31)

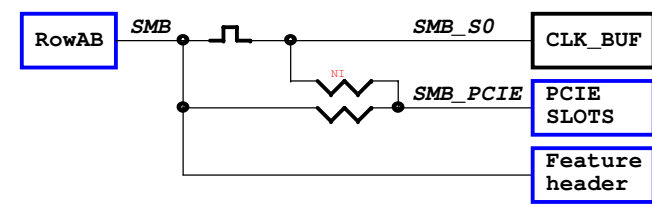
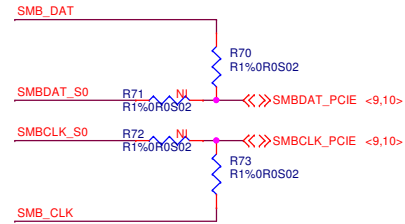
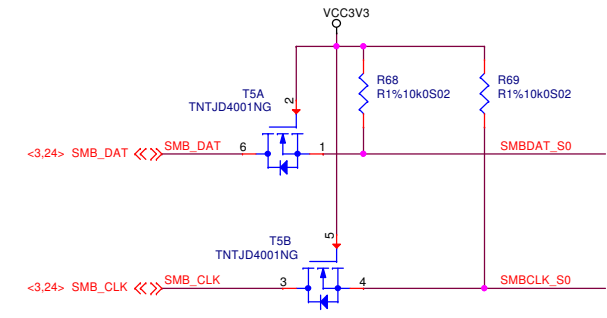

Congatec AG Auwiesenstrasse 5 D-94469 Deggendorf Germany			
Title: PCIE CLK			
Size: A3	Document Number: DEVA_A0	Created: -OrgAddr4-	Rev: A.0
Date: Sunday, April 23, 2017	Sheet: 8	of	30



PCI Express x16

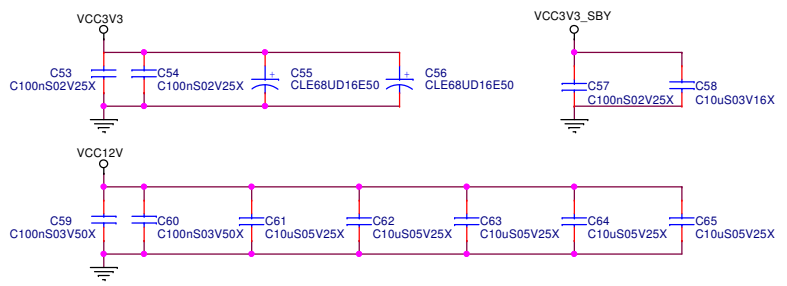
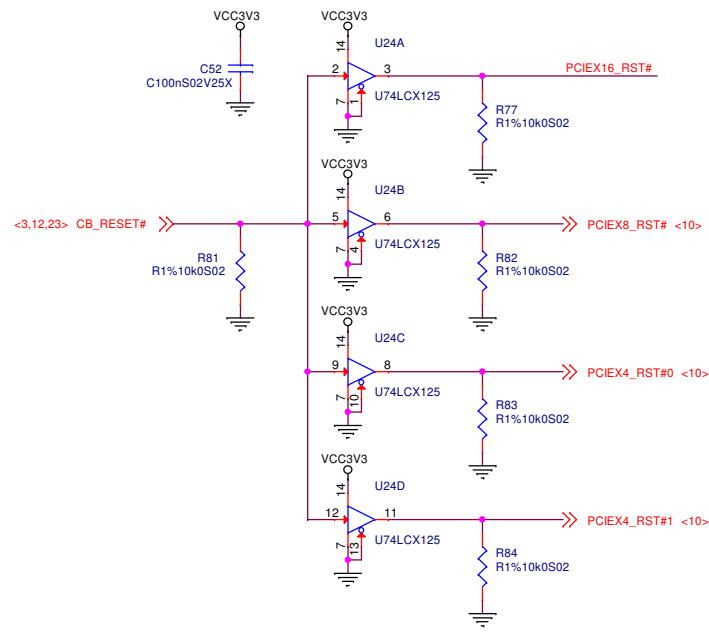
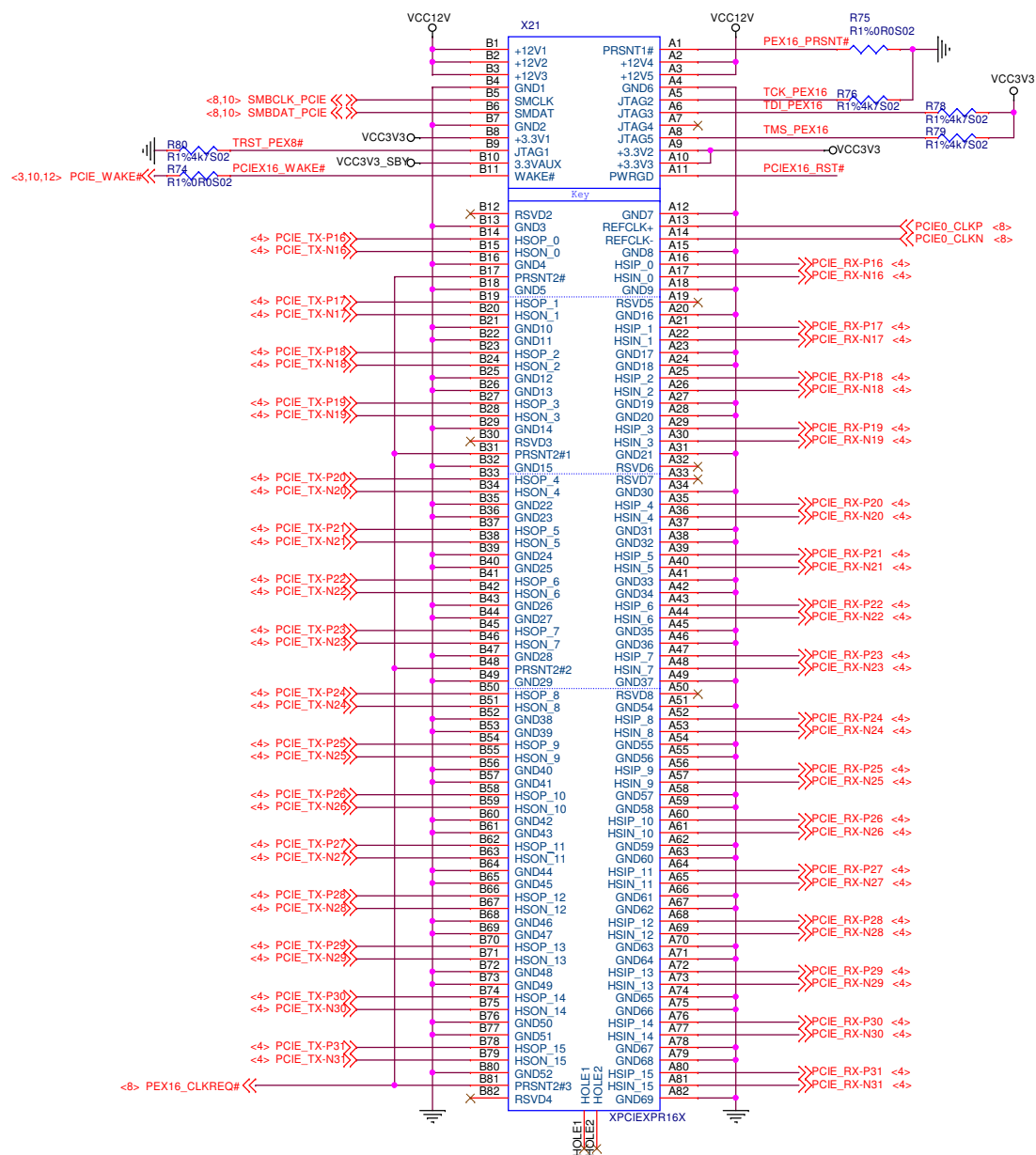

Congatec AG Auwiesenstrasse 5 D-94469 Deggendorf Germany			
Title: PCIEx16			
Size: A3	Document Number: DEVA_A0	Created: <OrgAddr>	Rev: A.0
Date: Sunday, April 23, 2017	Sheet: 9	of	30

**PCI Express x8**

A.0 modify

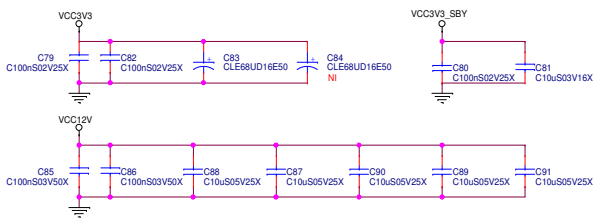
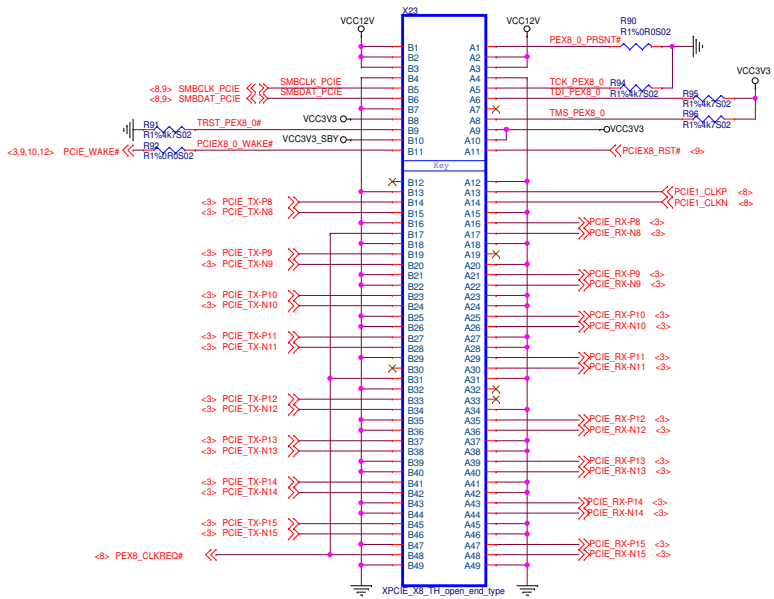

**PCI Express x4 P0**

A.0 modify

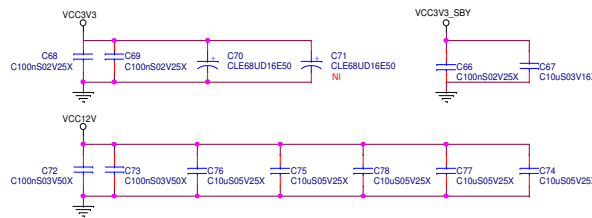
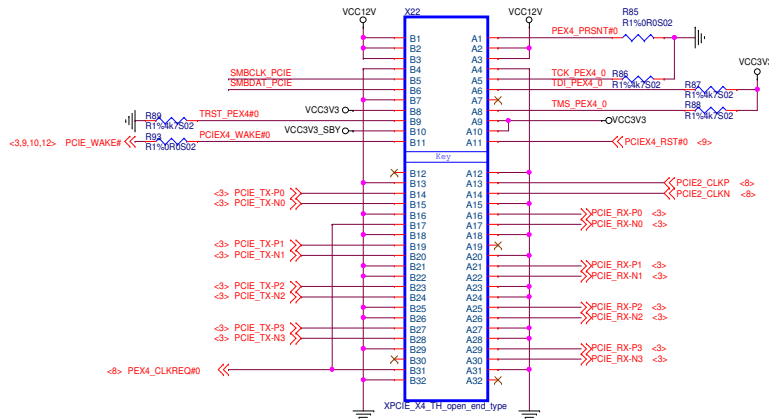

**PCI Express x4 P1**

A.0 modify

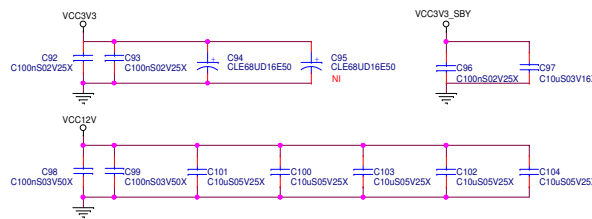
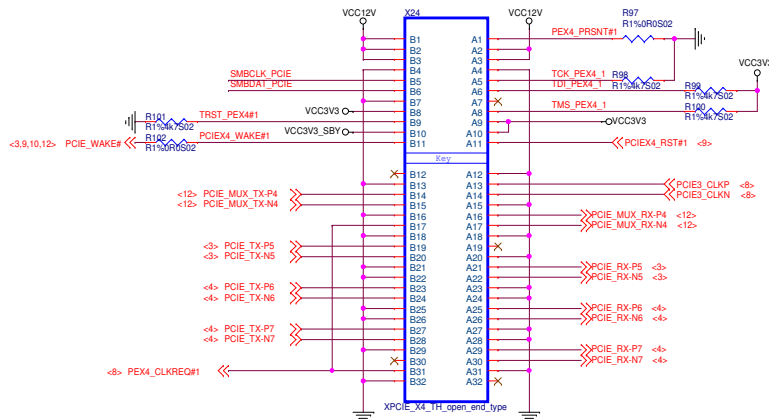

Remove in IT version

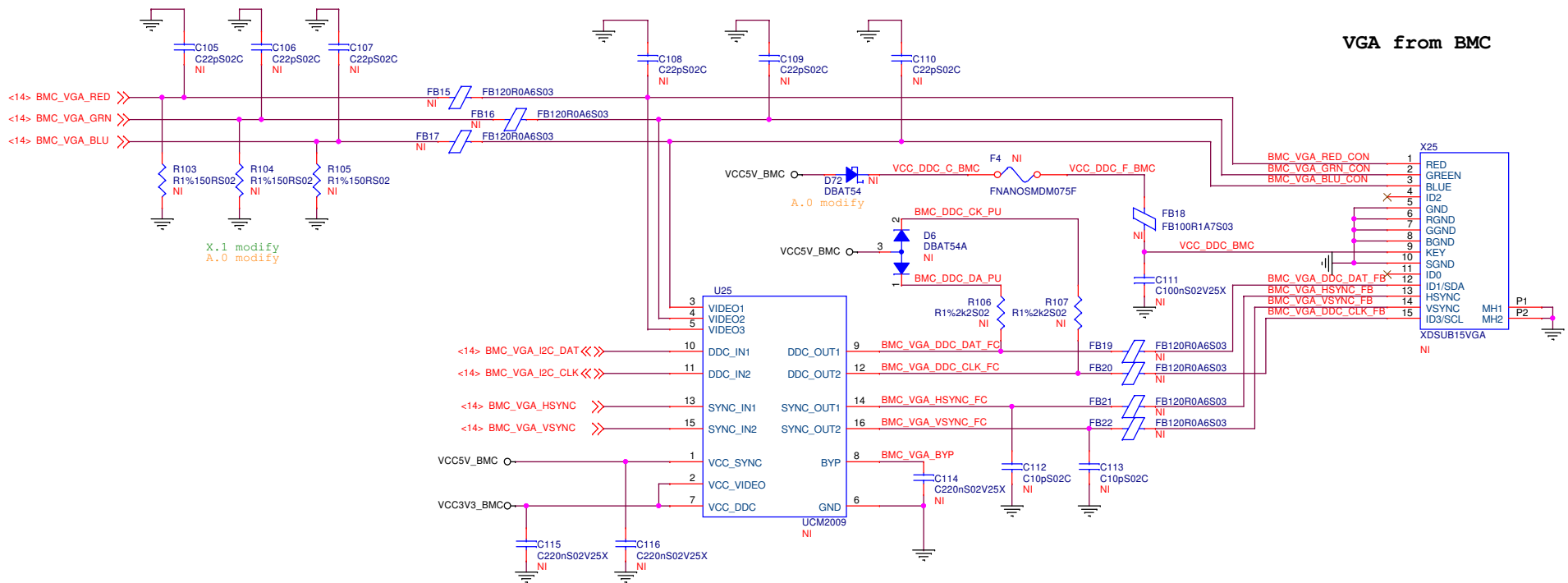

VGA from BMC

# SH12\_BMC (PCIE/DDR/I2C)

Remove in IT version

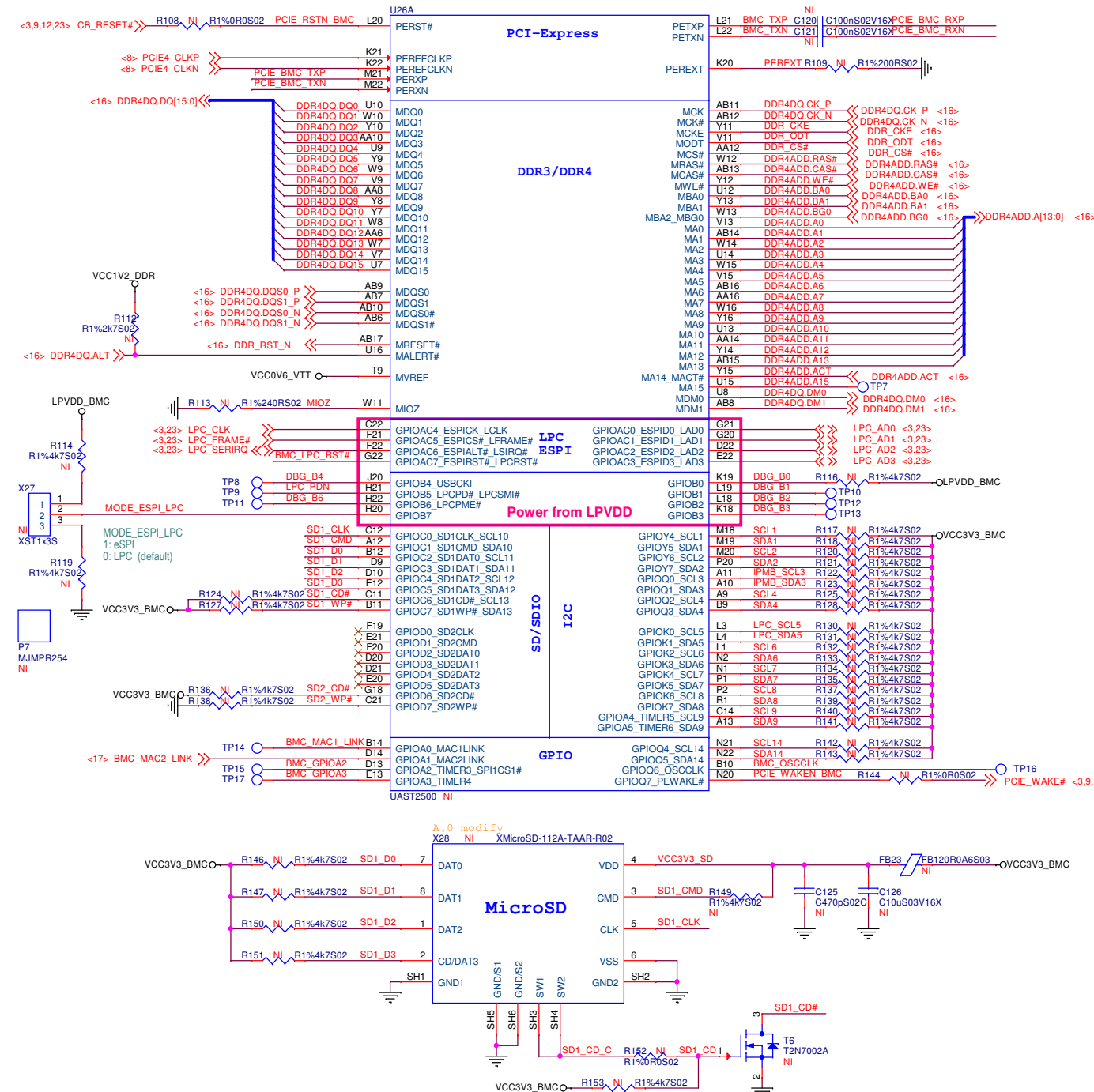

# PCIE P4 MUX

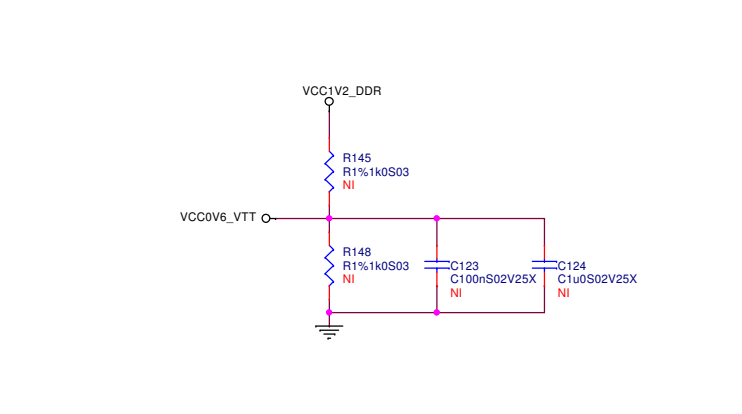
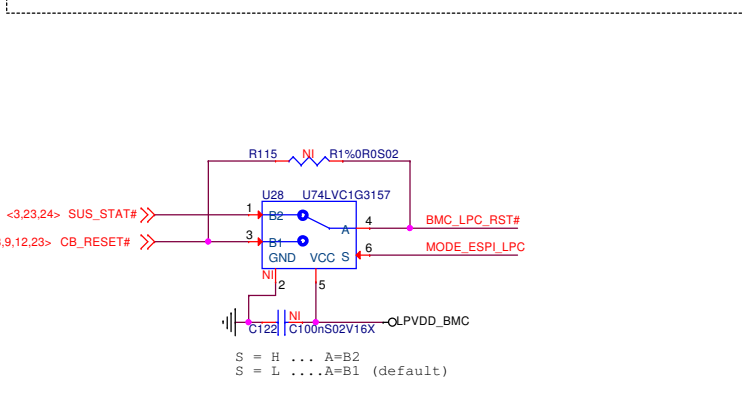
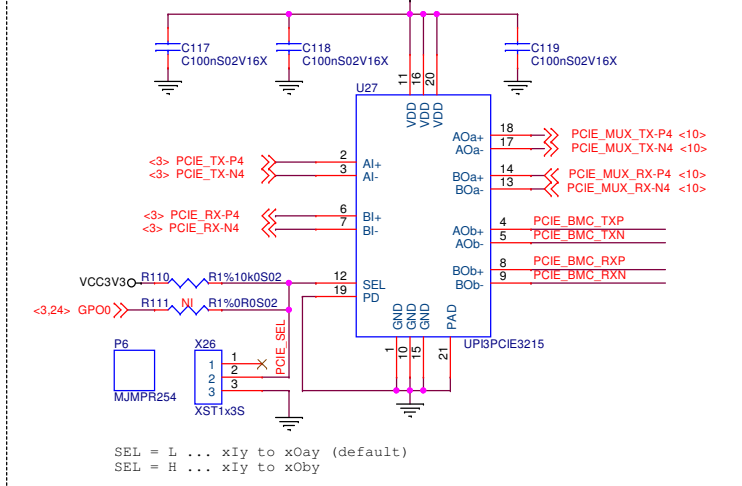

Congatec AG Auwiesenstrasse 5 D-94469 Deggendorf Germany			
Title: BMC(PCIE/DDR/I2C)			
Size A3	Document Number DEVA_A0	Created -OrgAddr4-	Rev A.0
Date: Sunday, April 23, 2017	Sheet 12	of 30	

# SH13\_BMC (UART/SPI/MAC)

Remove in IT version

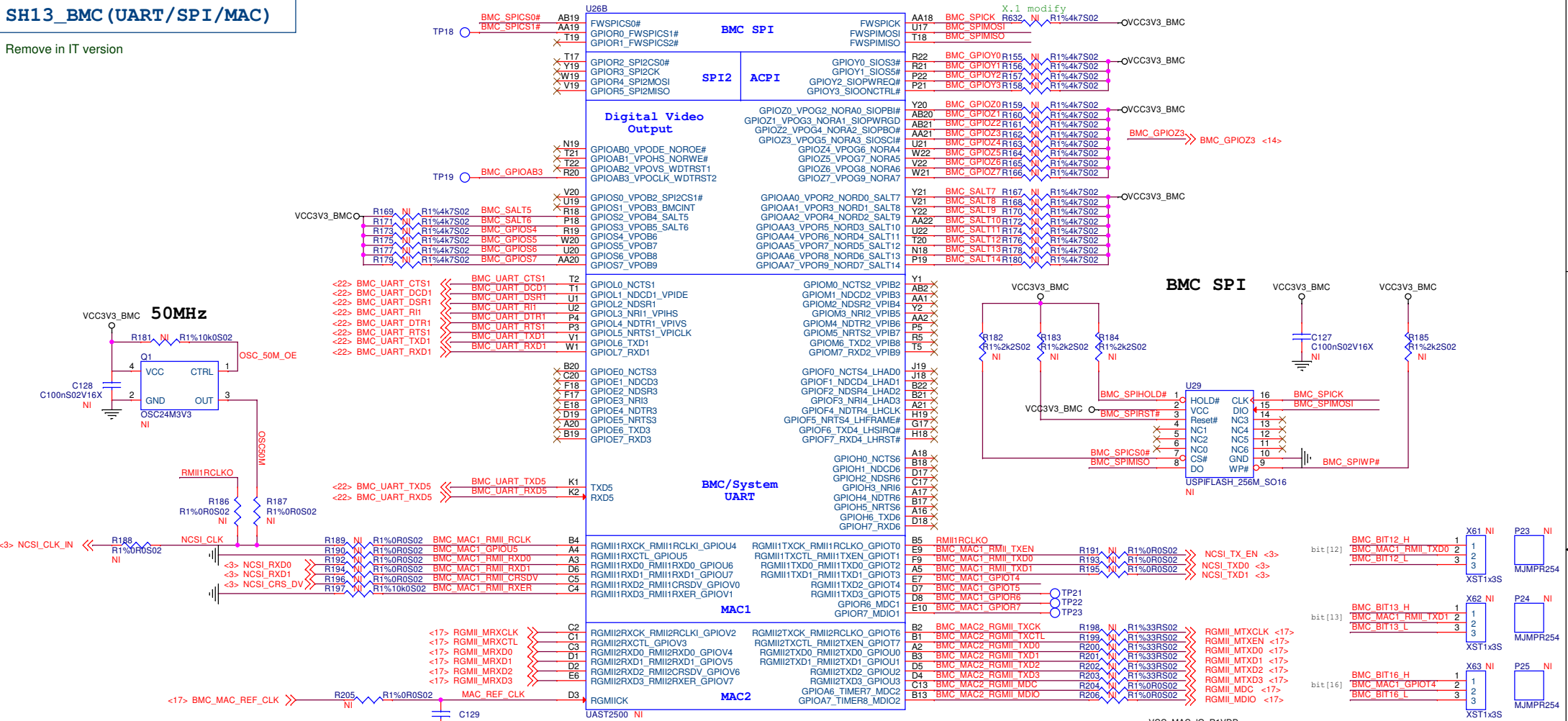

**Layout Notes:**  
 Maximum routing trace length:  
 MAC2: RGMII (1G/100M/10M bps) interface is 4 inches.

Pin	Definition	Value = 0	Value = 1
GPIOA4	VGA memory size selection	16 MB	64 MB
GPIOA5	Reserved	Default	Disallowed
GPIOA6	Enable VGA BIOS ROM	No	Yes
GPIOA7	VGA Class Code selection	Non-VGA	VGA
GPIOZ4	Enable BMC 2nd boot watchdog timer	No	Yes
GPIOZ5	Select USBCKI input frequency	24MHz	48MHz
GPIOZ6	Disable LPC to decode SuperIO address	No	Yes
GPIOZ7	Enable fast reset mode	No	Yes

X.1 modify

```

bit[6] MAC#1 interface type
0: RMII/NCSI 1: RGMII

bit[13]/bit[12]
SPI1 interface mode selection
00: Disable SPI interface [Default]
01: Enable SPI Master
10: Reserved (debug mode)
11: Enable SPI Pass-through

bit[16] SuperIO address selection
0: 0x2E 1: 0x4E [Default]

bit[19] Enable ACPI function
0: Disable 1: Enable

bit[7] MAC#1 interface type
0: RMII/NCSI 1: RGMII

bit[21] Enable GPIOD pass-through mode
0: Disable 1: Enable

bit[22] Enable GPIOE pass-through mode
0: Disable 1: Enable

bit[23] Select reference clock input mode
0: 24 MHz 1: 25 MHz

bit[24] Select DDR SDRAM mode
0: DDR3 1: DDR4
    
```

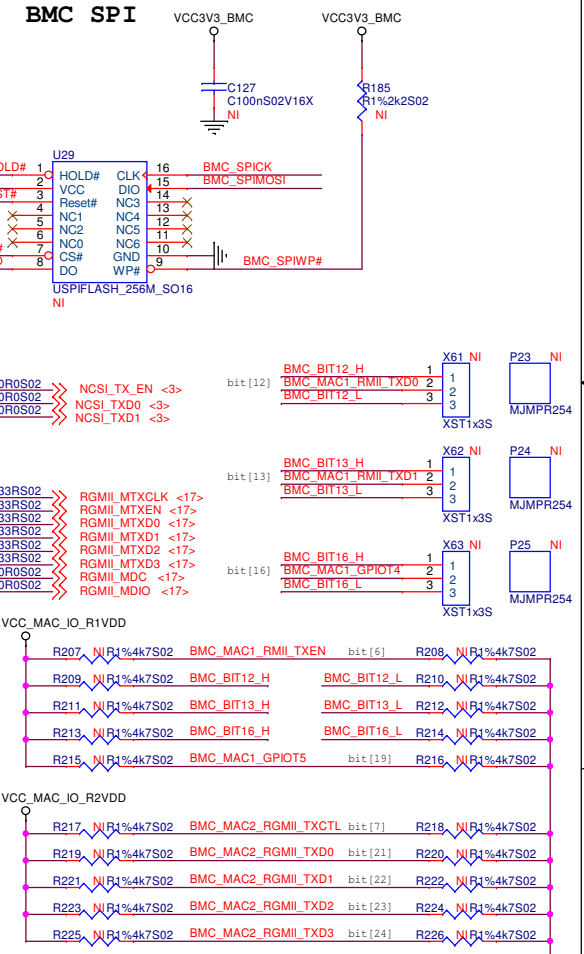

**Congatec AG**  
 Auwiesenstrasse 5  
 D-94469 Deggendorf  
 Germany

Title: BMC(UART/SPI/MAC)			
Size A3	Document Number: DEVA_A0	Created: <OrgAddr>	Rev: A.0
Date: Sunday, April 23, 2017	Sheet 13	of 30	

# SH14\_BMC (USB/ADC/DAC)

Remove in IT version

## BMC Heart Beat led

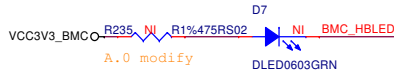

## BMC VBIOS

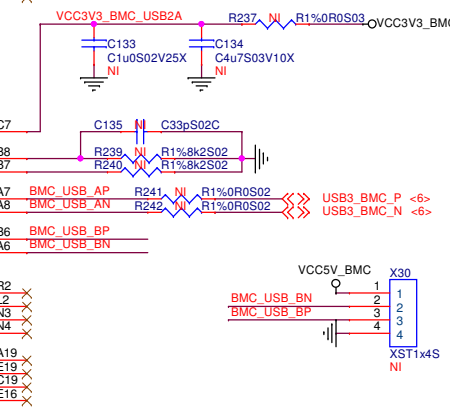
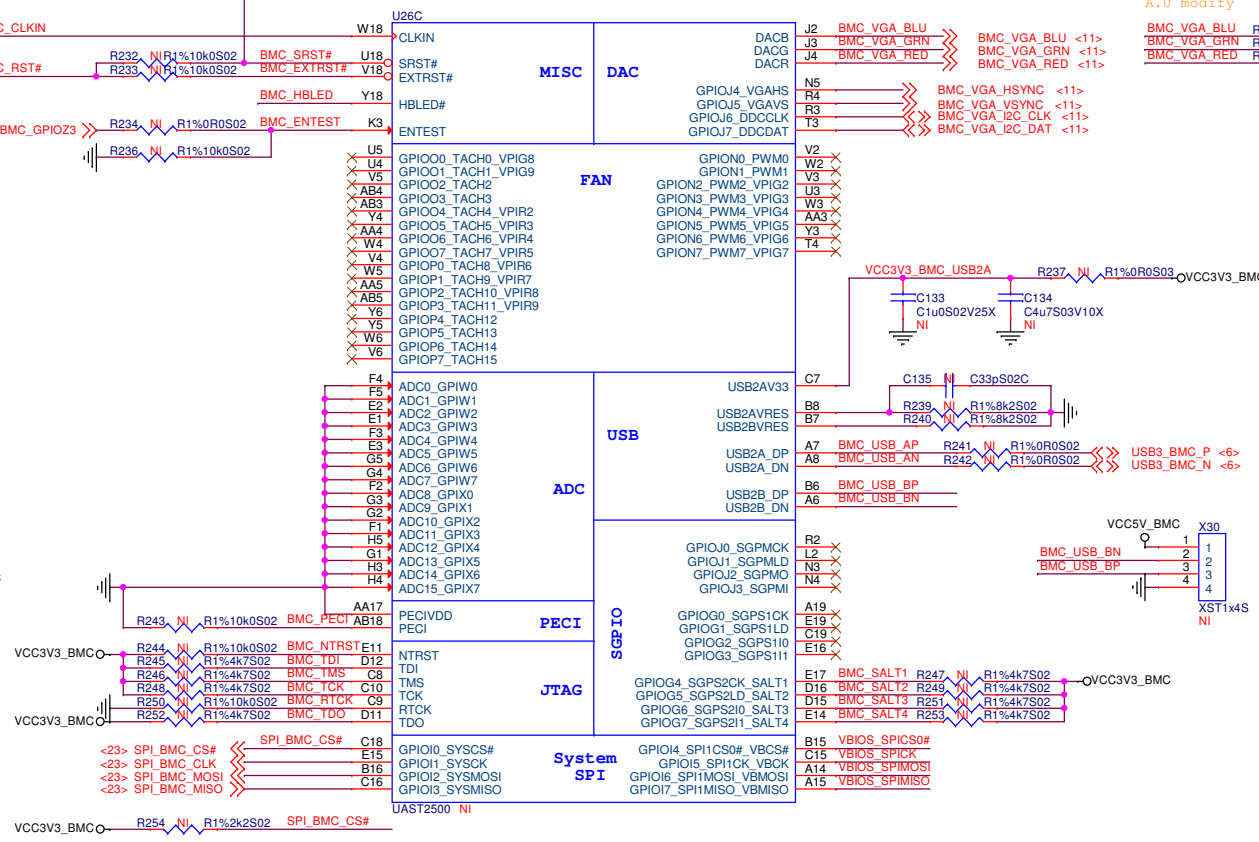
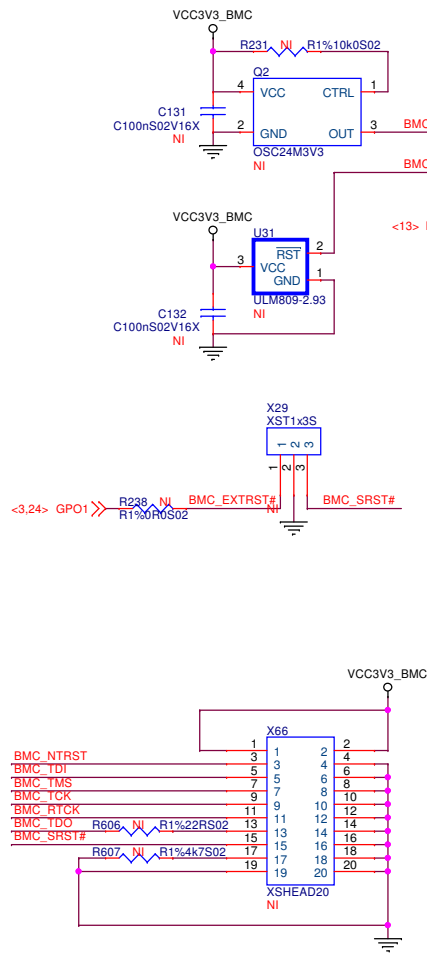
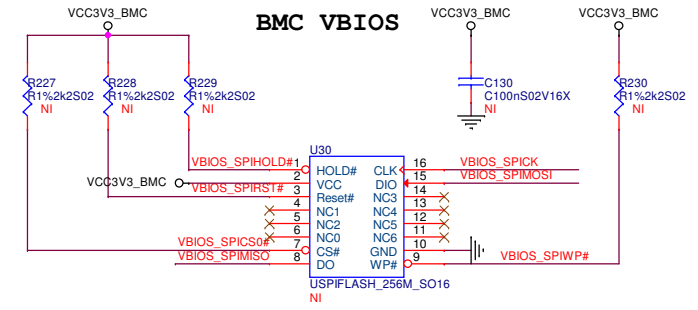

<Core Design>

Congatec AG Auwiesenstrasse 5 D-94469 Deggendorf Germany			
Title: BMC(USB/ADC/DAC)			
Size: A3	Document Number: DEVA_A0	Created: -OrgAddr4-	Rev: A.0
Date: Sunday, April 23, 2017	Sheet: 14	of: 30	

# SH15\_BMC (POWER)

Remove in IT version

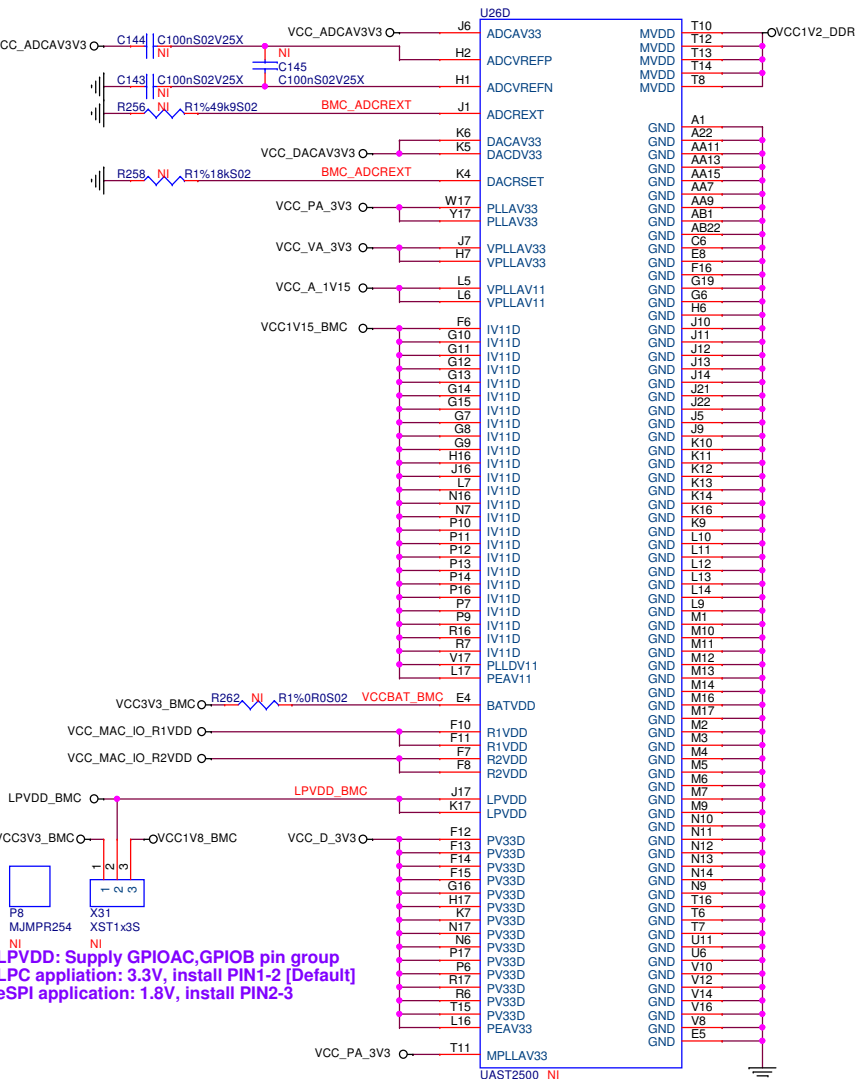

LPVDD: Supply GPIOAC,GPIOB pin group  
LPC application: 3.3V, install PIN1-2 [Default]  
eSPl application: 1.8V, install PIN2-3

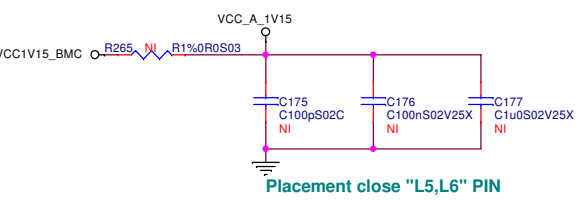
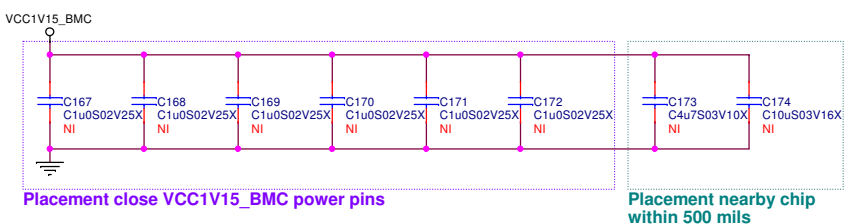
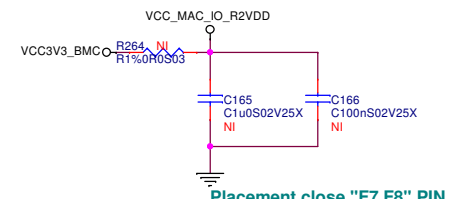
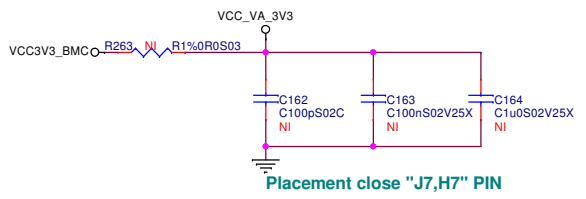
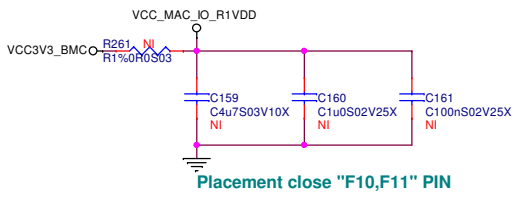
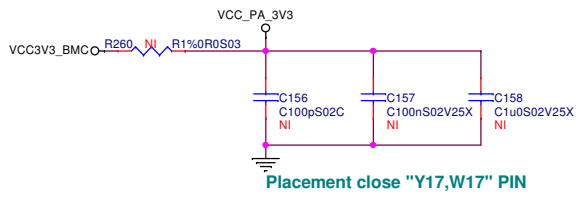
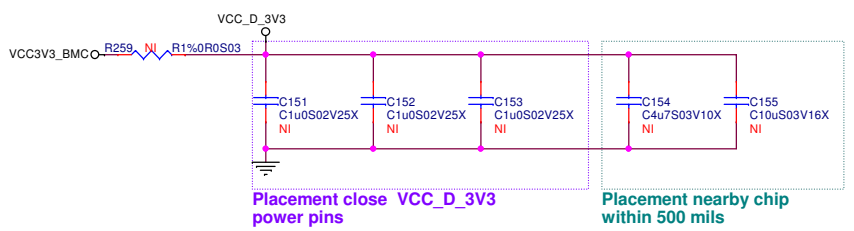
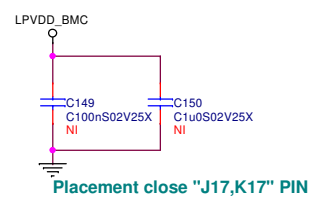
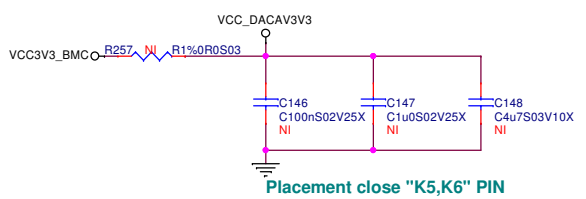
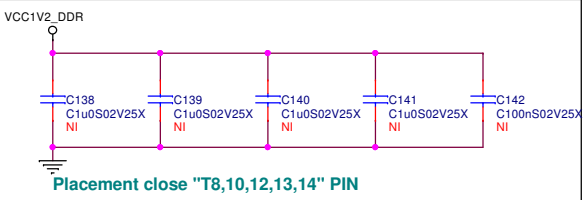
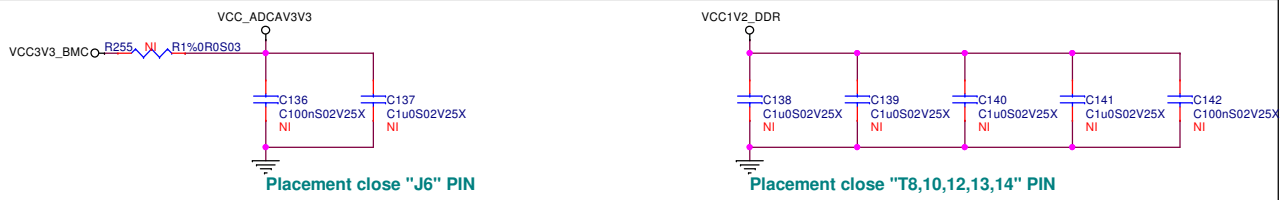

<Core Design>

Congatec AG  
Auwiesenstrasse 5  
D-94469 Deggendorf  
Germany

Title		BMC(POWER)	
Size	Document Number	Created	Rev
A3	DEVA_AD	-OrgAddr>	A.0
Date:	Sunday, April 23, 2017	Sheet	15 of 30

Remove in IT version

DDR4 256Mb X16

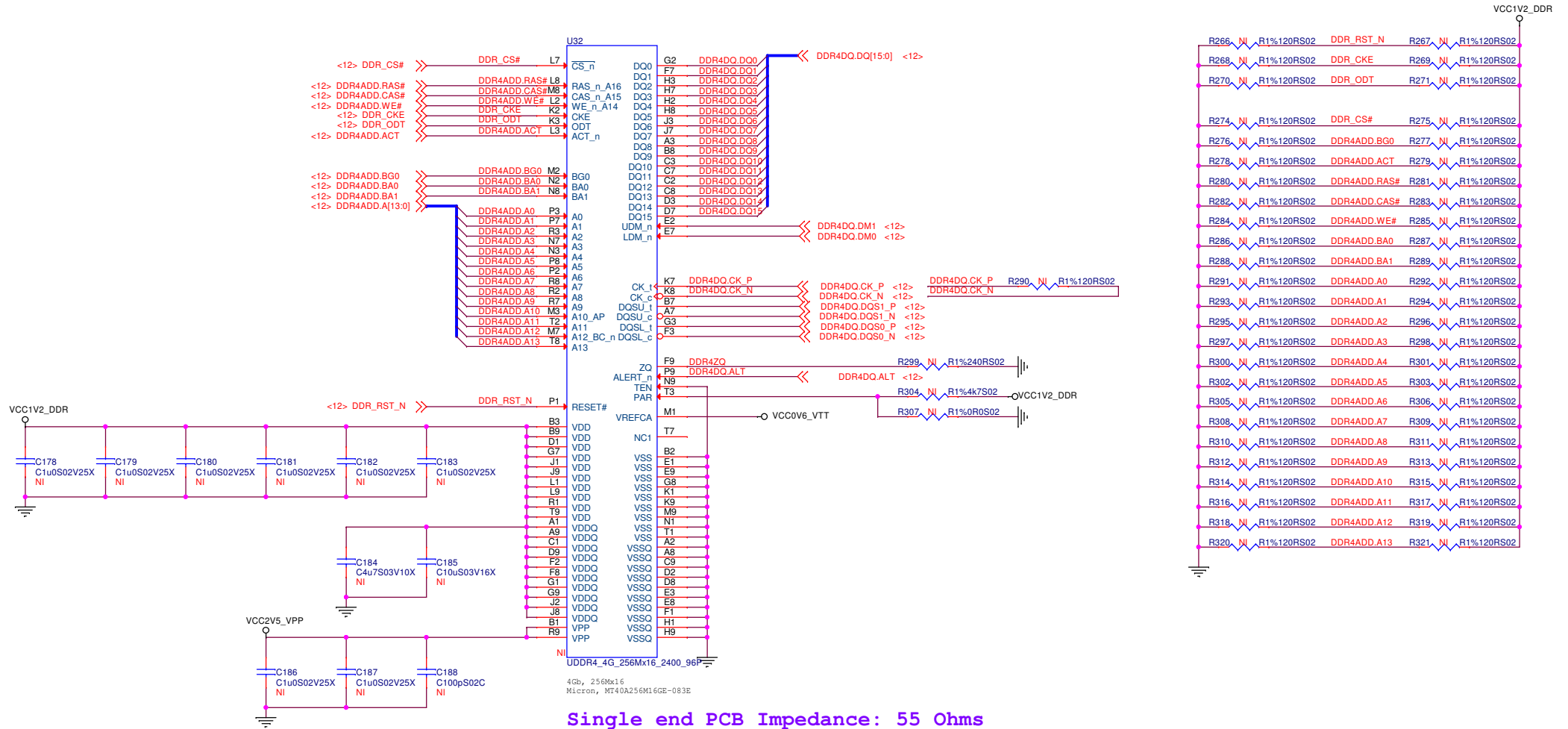

Single end PCB Impedance: 55 Ohms  
 Differential end : 110 Ohms

<Core Design>

Congatec AG Auwiesenstrasse 5 D-94469 Deggendorf Germany			
Title: DDR4 256Mx16			
Size A3	Document Number DEVA_A0	Created -OrgAddr4-	Rev A.0
Date: Sunday, April 23, 2017	Sheet 16	of 30	



# SH17\_RGMII

Remove in IT version

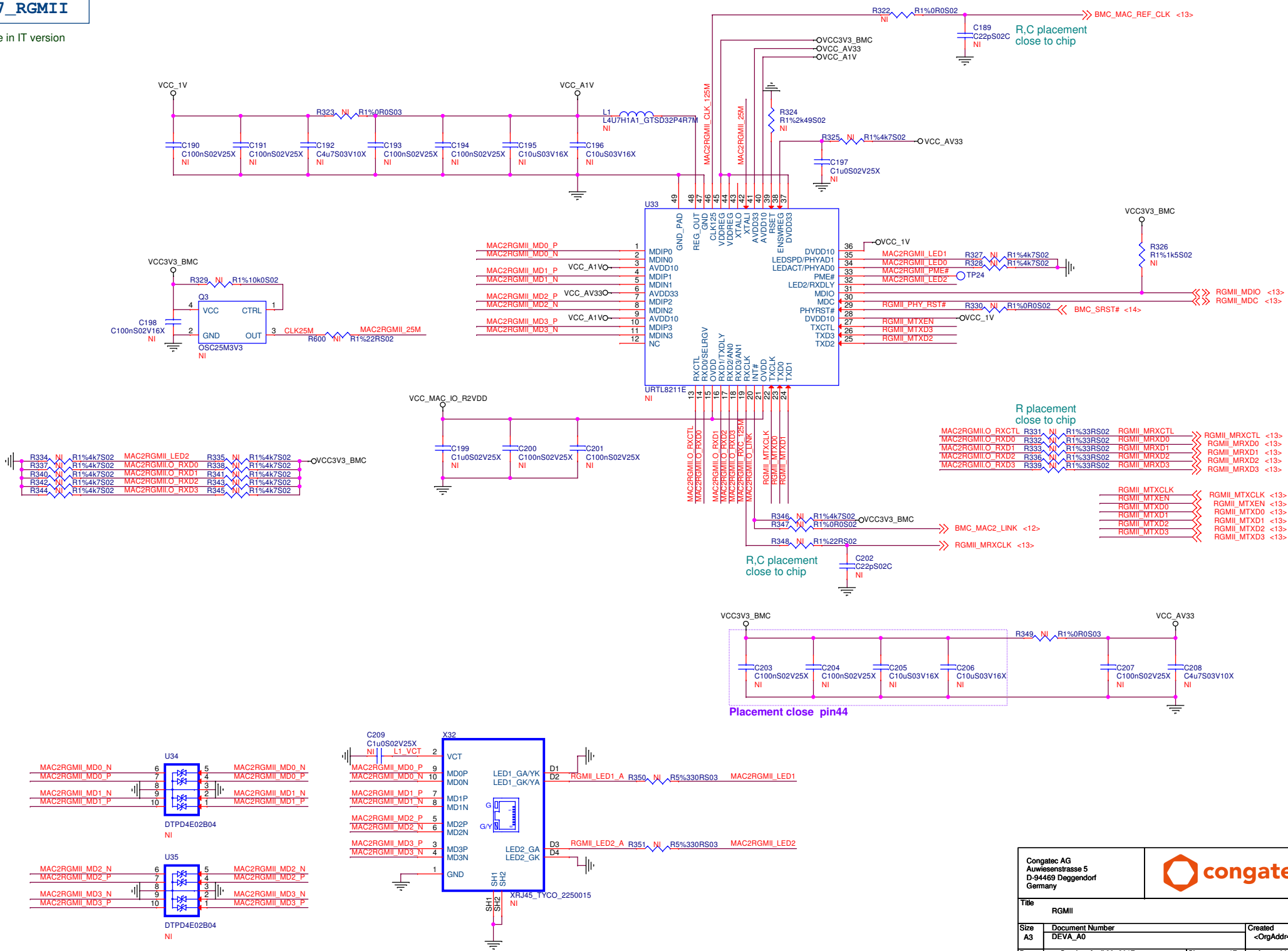

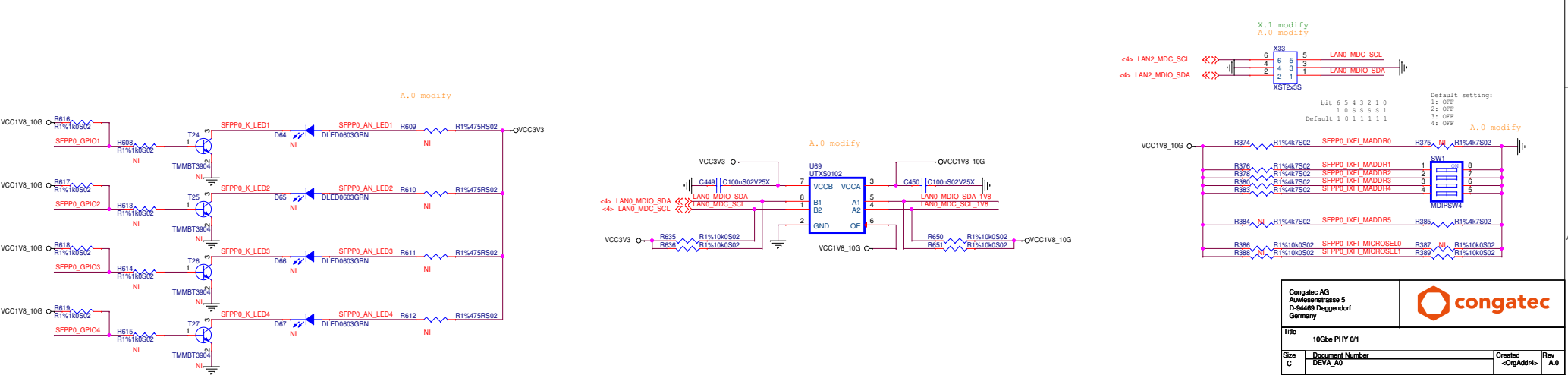
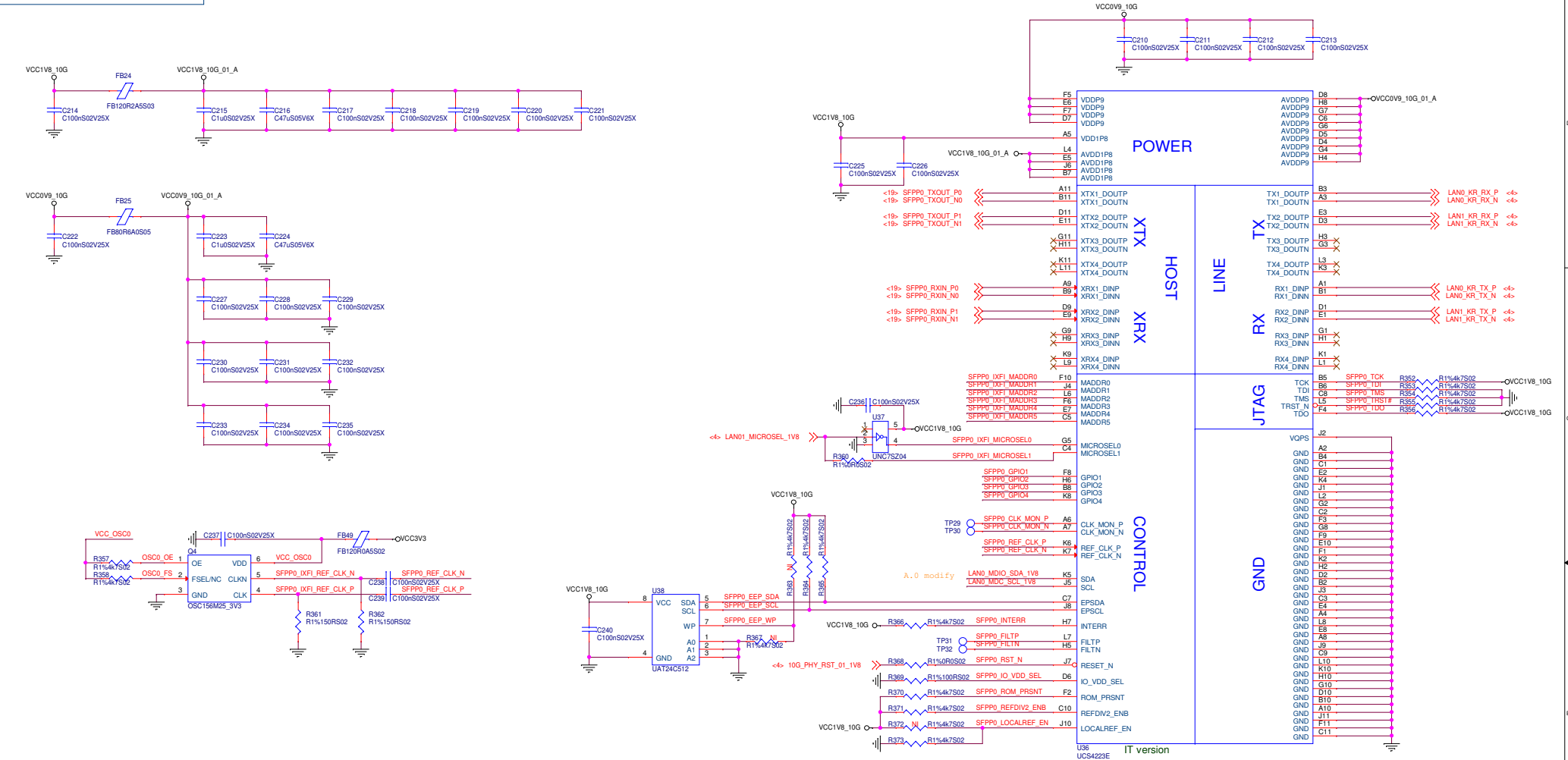

<b>Congatec AG</b> Auwiesenstrasse 5 D-94469 Deggendorf Germany			
Title: RGMII			
Size: A3	Document Number: DEVA_A0	Created: Sunday, April 23, 2017	Rev: A.0
Date: Sunday, April 23, 2017	Sheet: 17	of: 30	

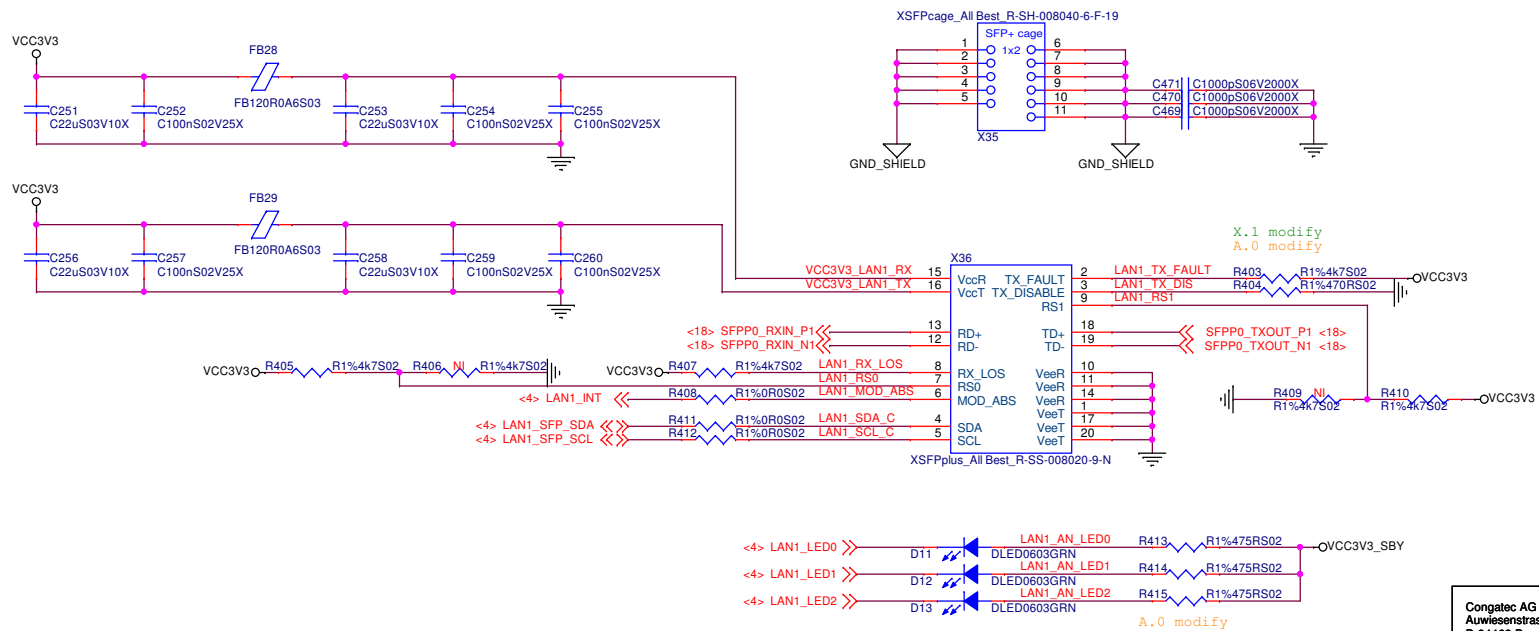
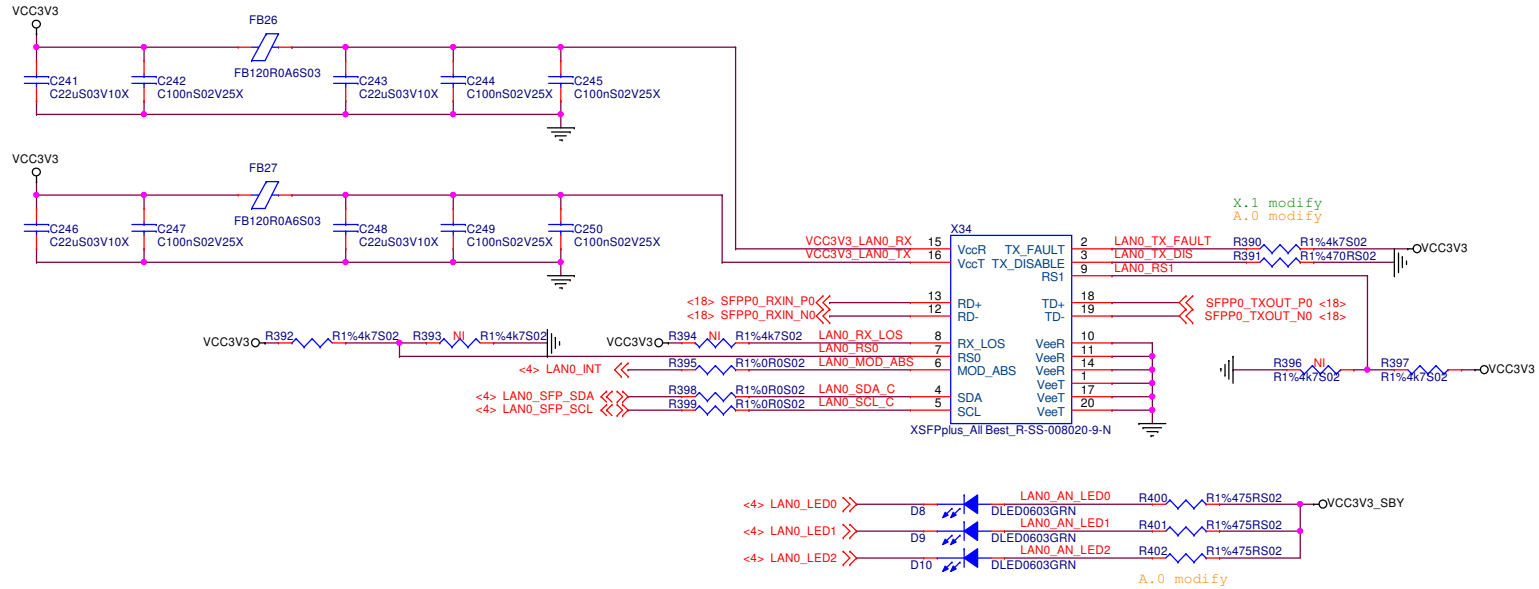

# SH19\_10Gbe SFP+ 0/1

CHECK STRAP



Congatec AG Auwiesenstrasse 5 D-94469 Deggendorf Germany			
Title: 10Gbe SFP+ 0/1			
Size: A3	Document Number: DEVA_A0	Created: <OrgAddr>	Rev: A.0
Date: Thursday, May 11, 2017	Sheet: 19	of: 30	

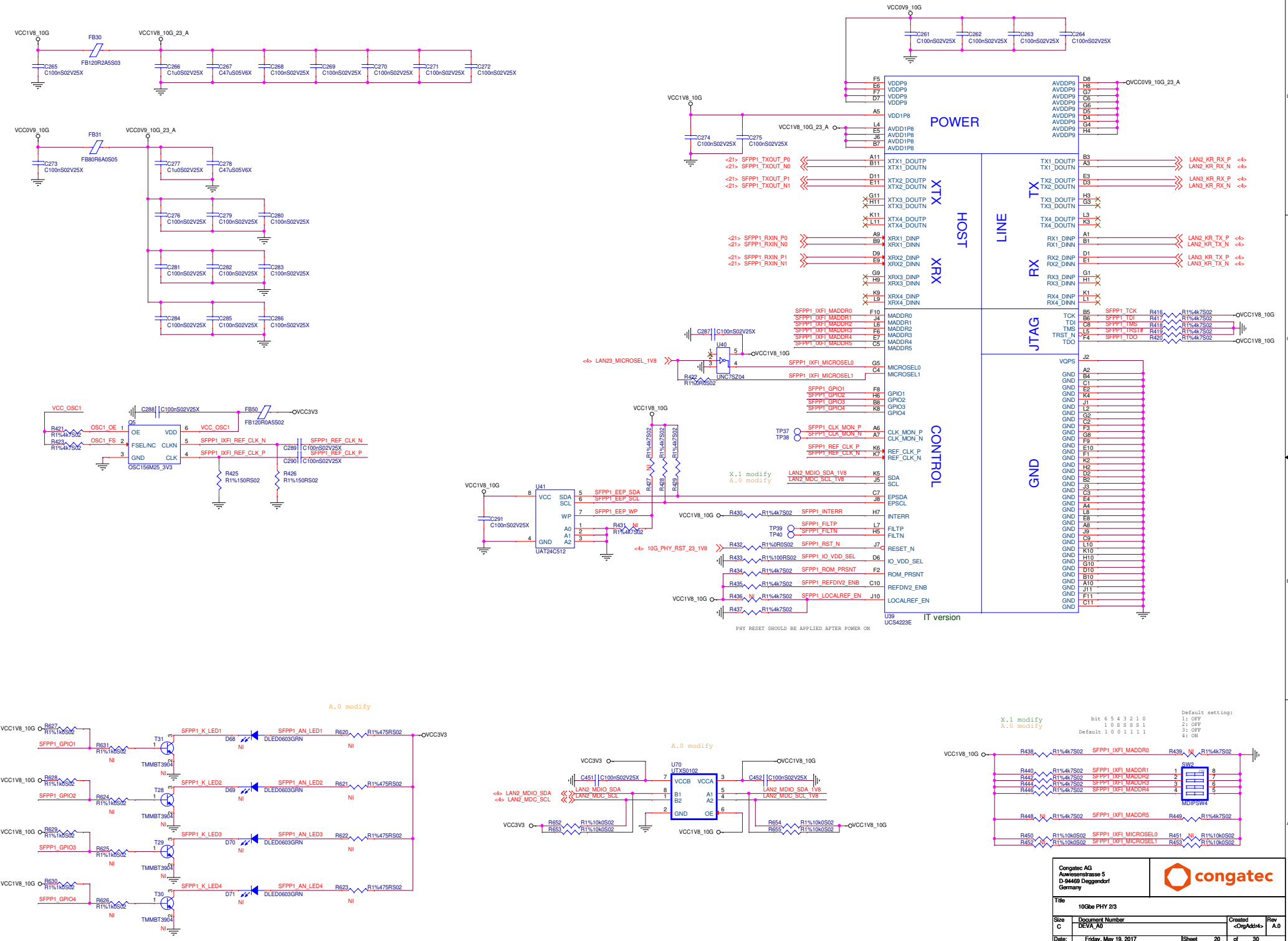

Congatec AG Auenrostrasse 5 D-94469 Deggendorf Germany	
Title: 10GbE PHY 2/3	
Size: C	Document Number: DEVA_A0
Date: Friday, May 18, 2017	Created: <OrgAdmin>
ISheet: 20	of 30

# SH21\_10Gbe SFP+ 2/3

CHECK STRAP

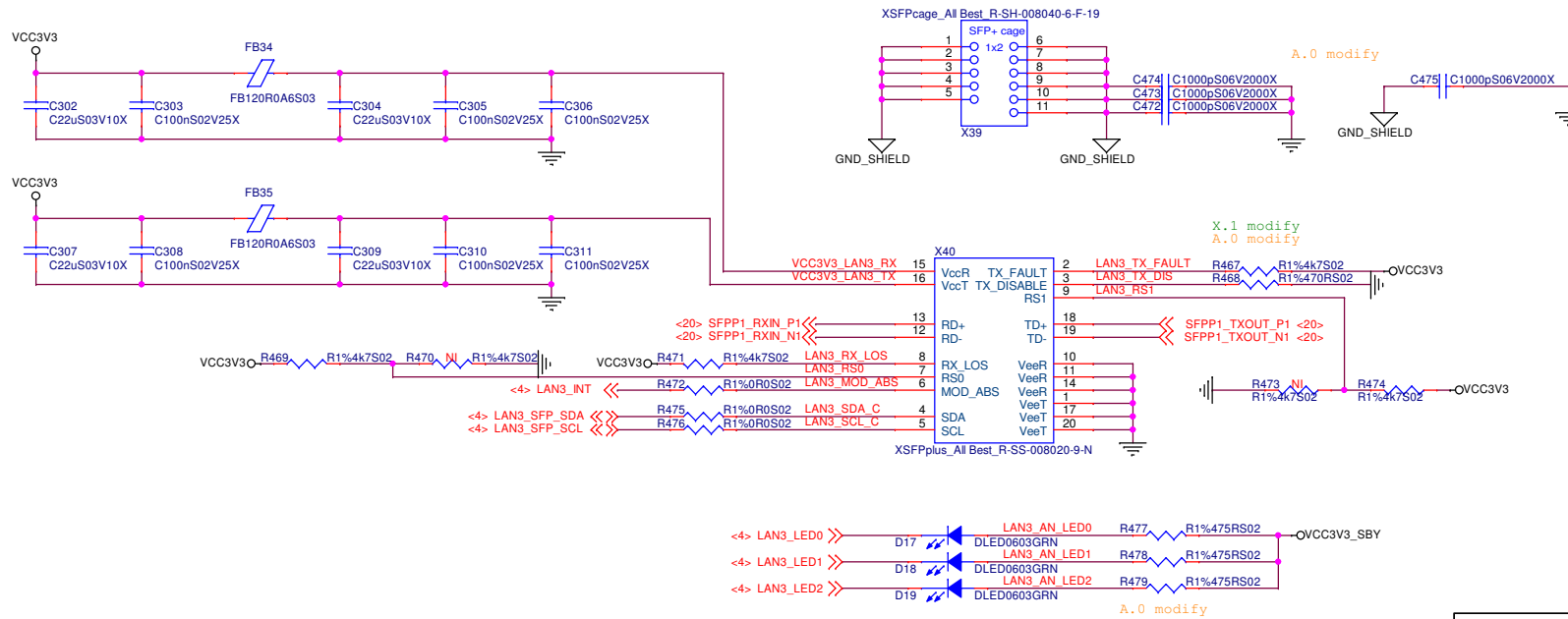
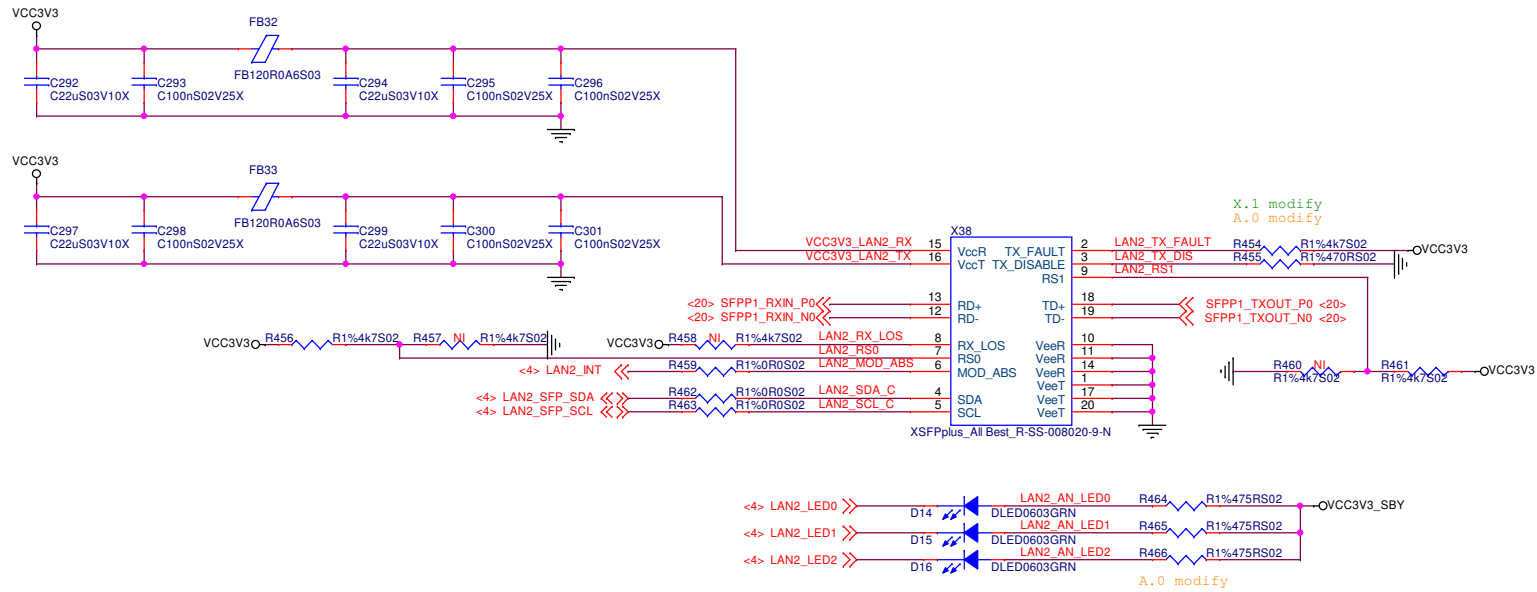

Congatec AG Auwiesenstrasse 5 D-94469 Deggendorf Germany			
Title: 10Gbe SFP+ 2/3			
Size A3	Document Number DEVA_A0	Created -OrgAddr-	Rev A.0
Date: Thursday, May 11, 2017	Sheet 21	of 30	

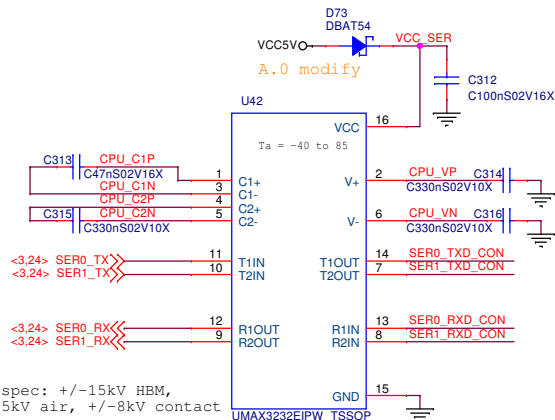

ESD spec: +/-15kV HBM,  
+/-15kV air, +/-8kV contact

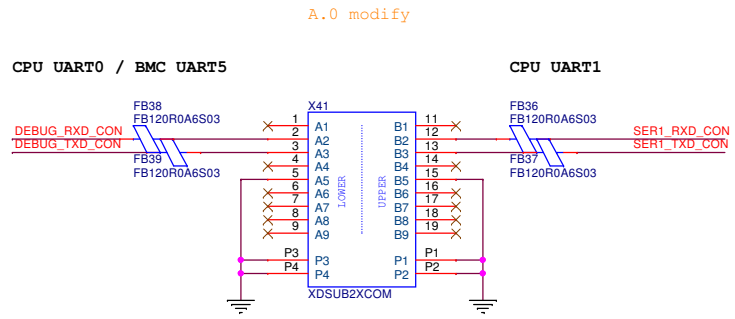

Remove in IT version

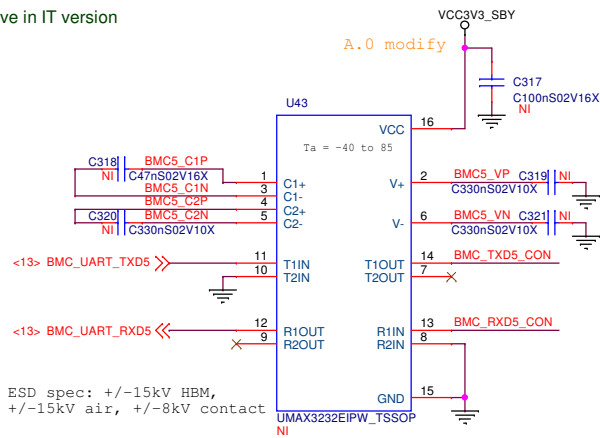

ESD spec: +/-15kV HBM,  
+/-15kV air, +/-8kV contact

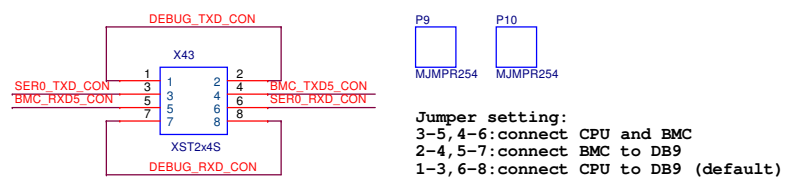

**Jumper setting:**  
 3-5, 4-6: connect CPU and BMC  
 2-4, 5-7: connect BMC to DB9  
 1-3, 6-8: connect CPU to DB9 (default)

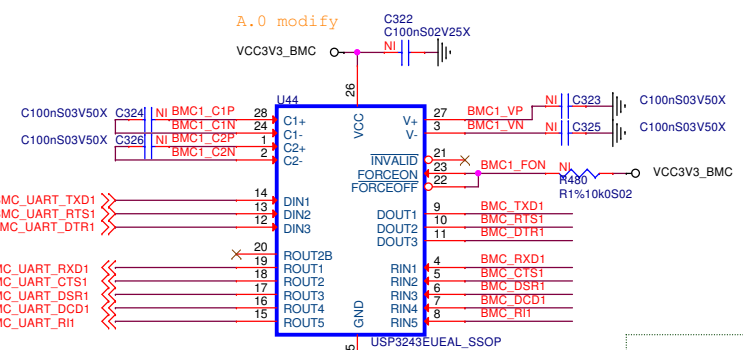

ESD spec: +/-15kV HBM,  
+/-15kV air, +/-8kV contact  
Max. Data Rate: 1Mbps

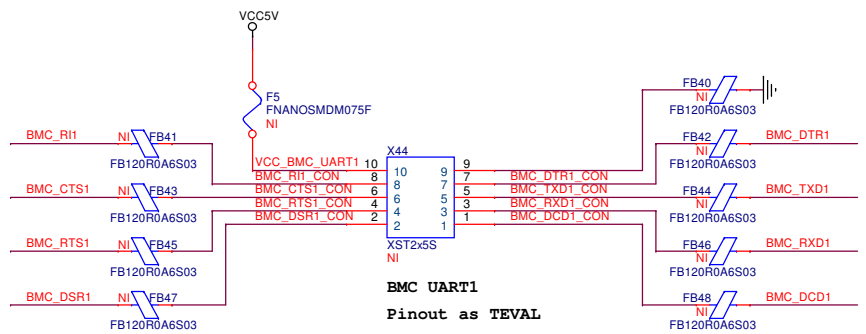

Congatec AG  
 Auwiesenstrasse 5  
 D-94469 Deggendorf  
 Germany



Title UART			
Size A3	Document Number DEVA_A0	Created -OrgAddr-	Rev A.0
Date: Thursday, May 11, 2017	Sheet 22	of	30

### SPI BIOS Flash

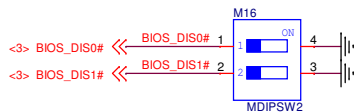
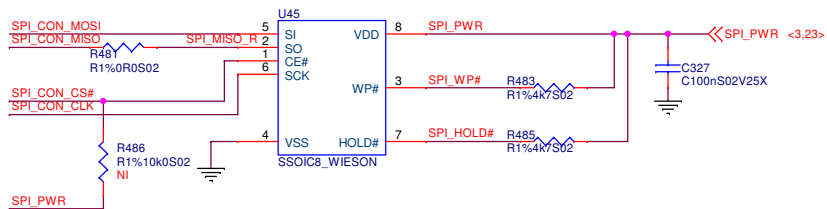

BIOS_DIS1#	BIOS_DIS0#	BIOS ENTRY / SPI_CS#
OFF	OFF	on-module firmware (default)
OFF	ON	carrier FWH (not supported)
ON	OFF	carrier firmware from SPI
ON	ON	on-module firmware, carrier SPI contains management data

### SPI BIOS jumper

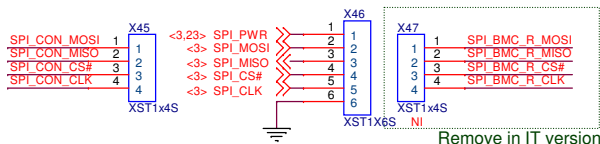

Remove in IT version

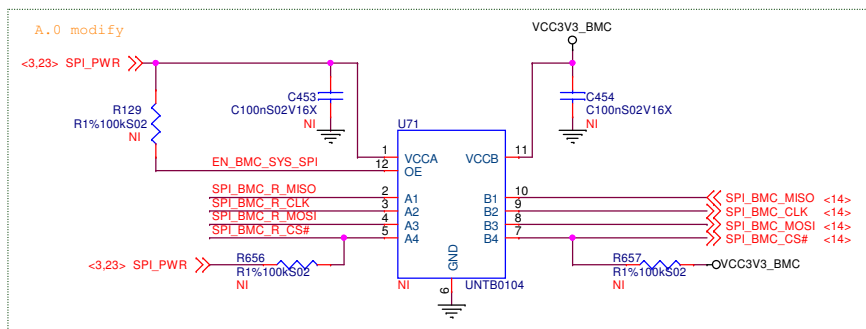

### SPI BIOS jumper placement

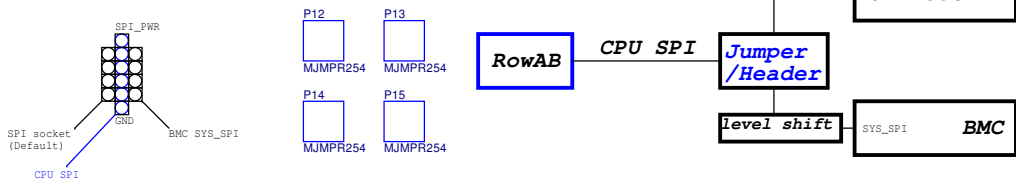

### I2C EEPROM

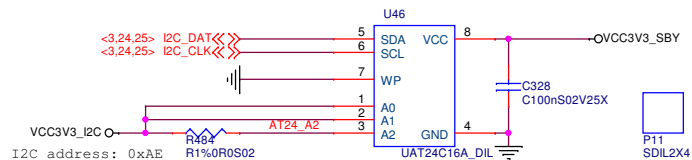

### LPC/TPM header

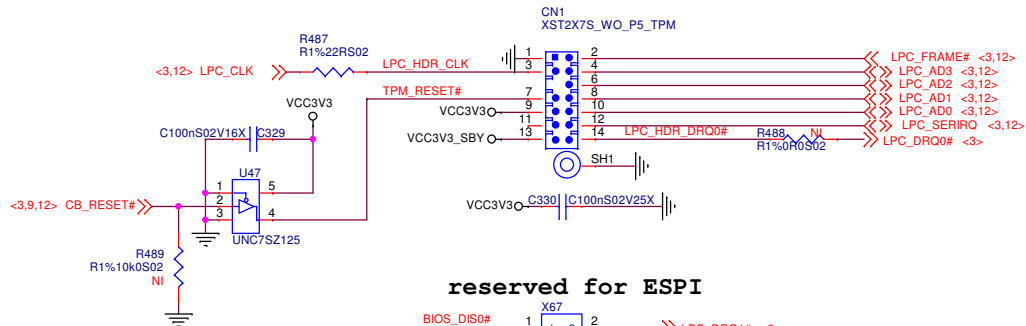

### reserved for ESPI

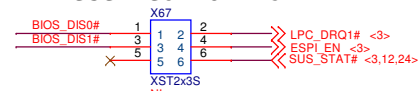

### Type detection

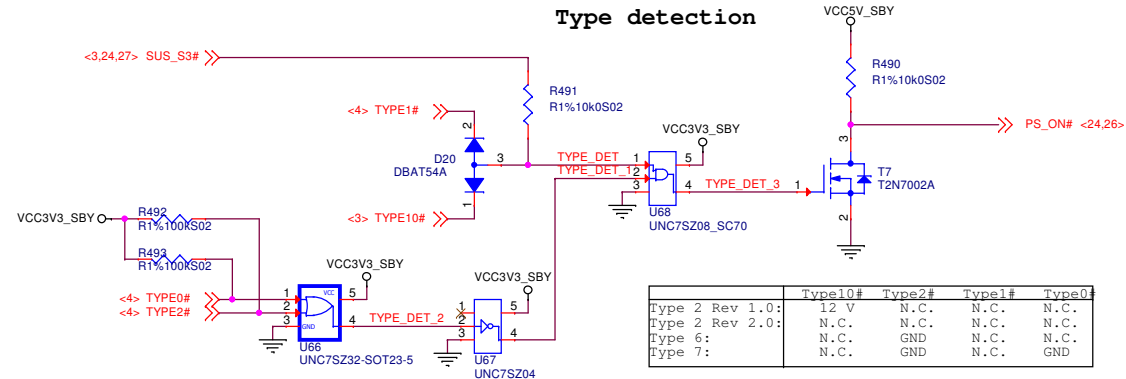

Type	Rev	Type10#	Type2#	Type1#	Type0#
Type 2	Rev 1.0:	12 V	N.C.	N.C.	N.C.
Type 2	Rev 2.0:	N.C.	N.C.	N.C.	N.C.
Type 6:		N.C.	GND	N.C.	N.C.
Type 7:		N.C.	GND	N.C.	GND

Congatec AG  
 Auwiesenstrasse 5  
 D-94469 Deggendorf  
 Germany



Title SPI / I2C / TPM			
Size A3	Document Number DEVA_A0	Created -OrgAddr4-	Rev A.0
Date: Sunday, April 23, 2017	Sheet 23	of 30	

RTC / CMOS Battery

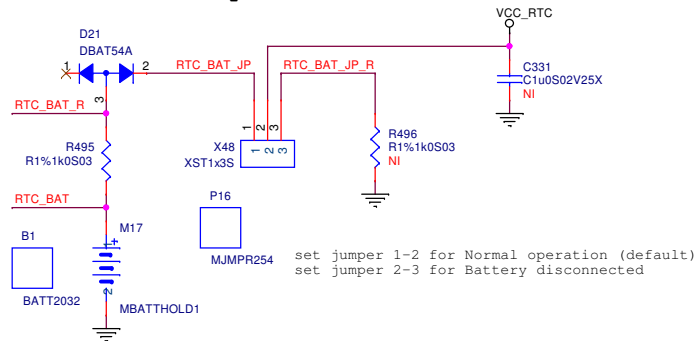

PC beep

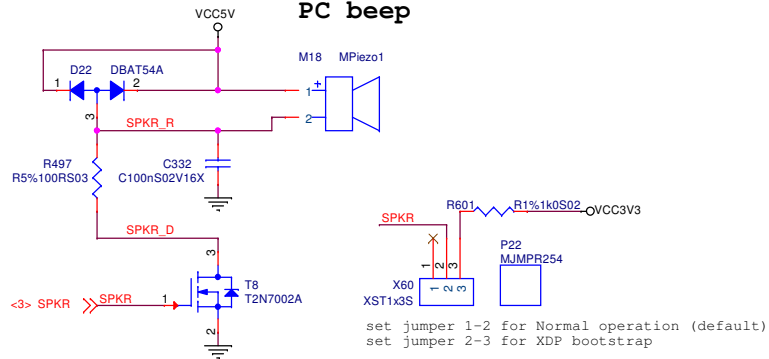

FAN Control

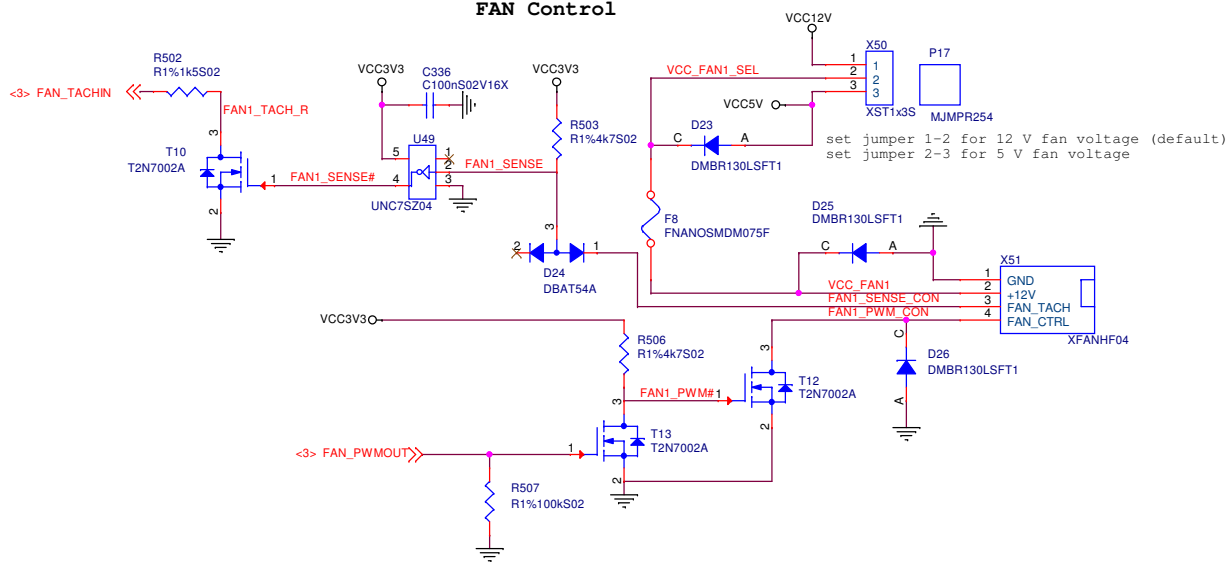

FEATURE

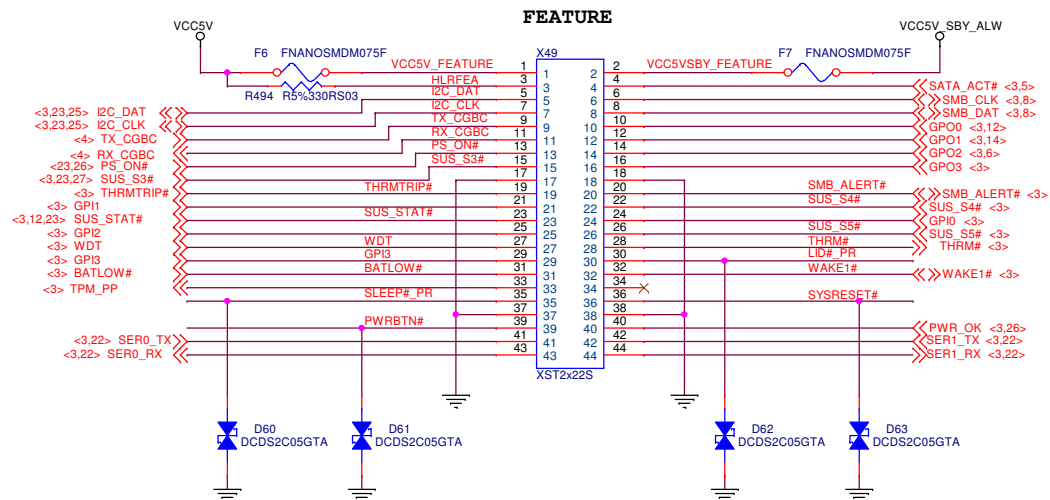

Power Button

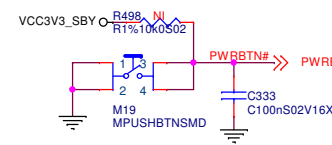

Reset Button

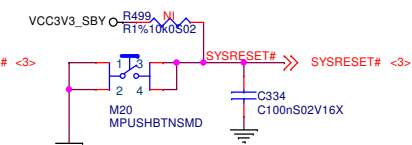

LID Button

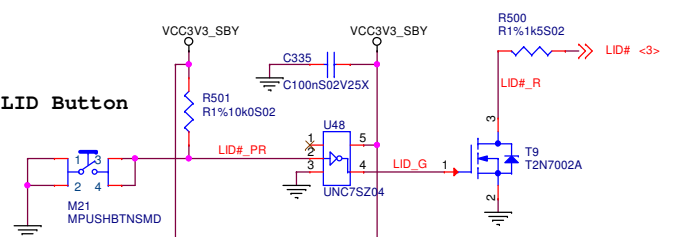

SLEEP Button

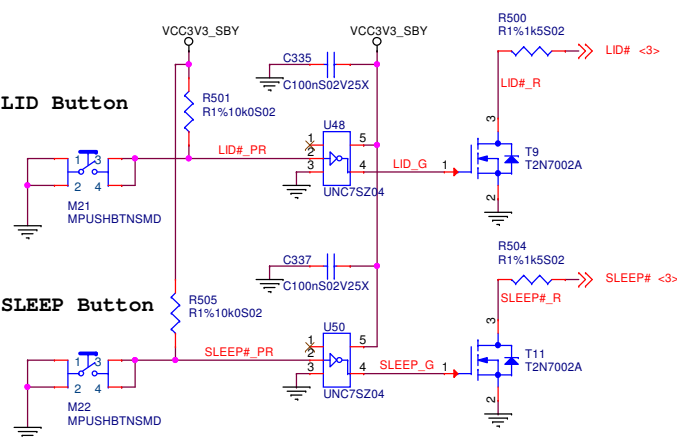

Congatec AG  
 Auwiesenstrasse 5  
 D-94469 Deggendorf  
 Germany





Title			
SPK / Feature / FAN / RTC / BTN			
Size	Document Number	Created	Rev
A3	DEVA_A0	-OrgAddr4-	A.0
Date:	Sunday, April 23, 2017	Sheet	24 of 30

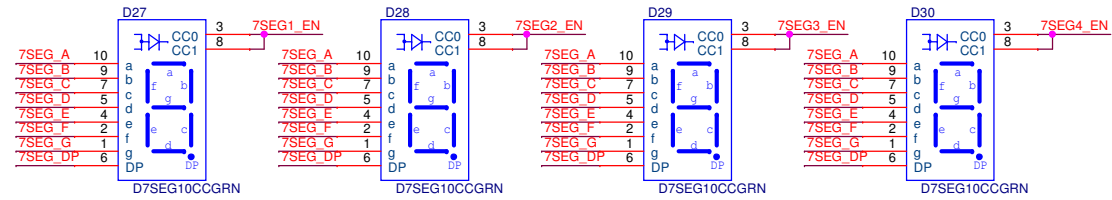
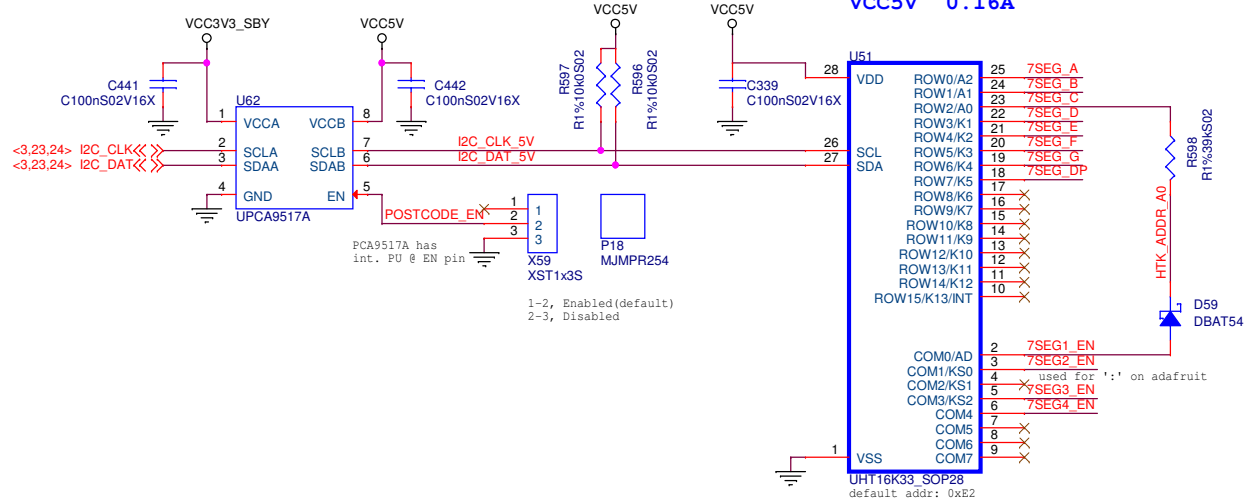

# Postcode Display

VCC5V 0.16A



Congatec AG Auwiesenstrasse 5 D-94469 Deggendorf Germany			
Title Post code			
Size	Document Number	Created	Rev
B	DEVA_A0	<OrgAddr4>	A.0
Date:	Sunday, April 23, 2017	Sheet	25 of 30

**ATX Power**

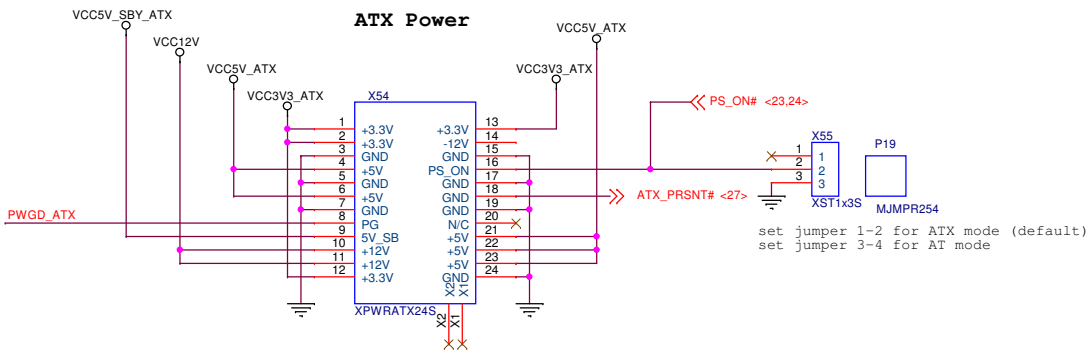

**PWR\_OK to COME**

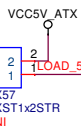
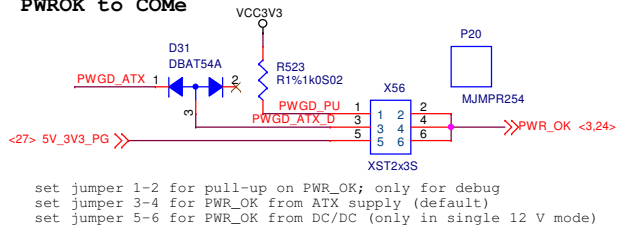

load resistors causing additional 200 mA load current at 5V\_ATX helping ATX PSU to turn on

**Power In connectors - BANANA JACK**

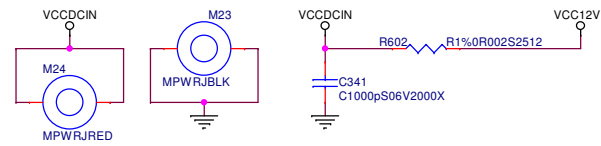

**VCC5V\_SBY\_ALW ORing**

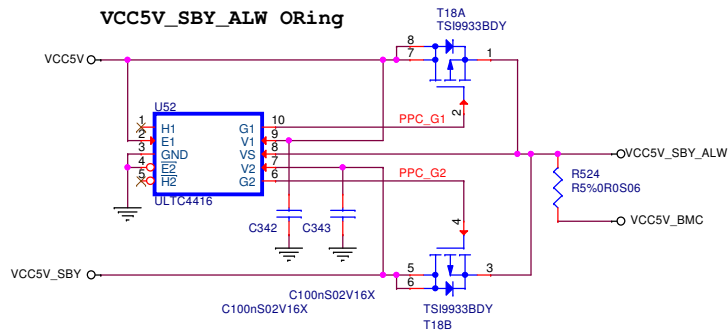

**3.3 V Standby**

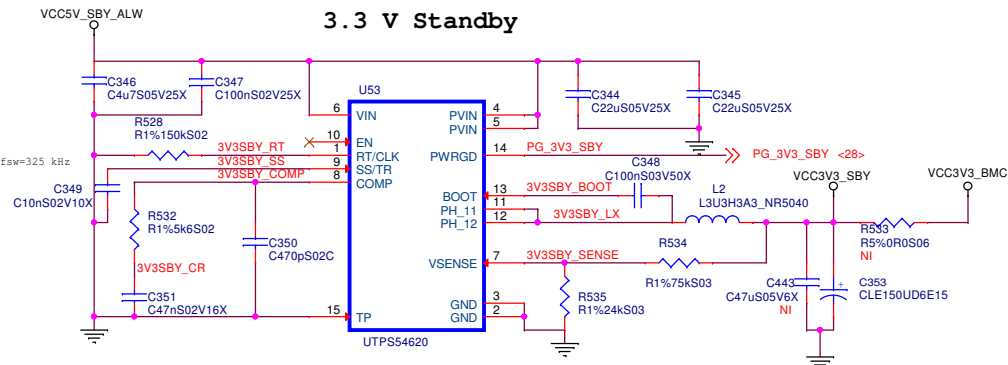

A.0 modify

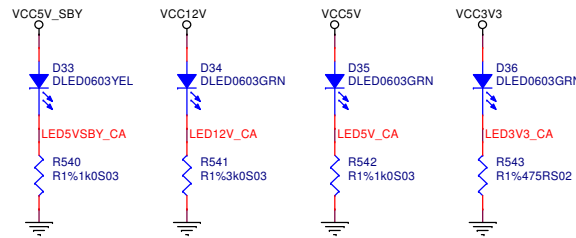
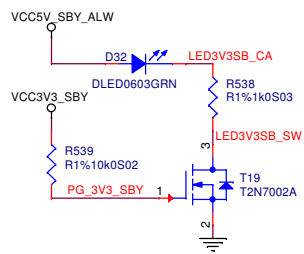
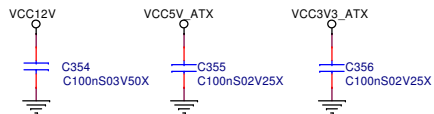

Congatec AG  
Auwiesenstrasse 5  
D-94469 Deggendorf  
Germany



Title		Power / 5VSBY / 3V3SBY	
Size	Document Number	Created	Rev
A3	DEVA_A0	<OrgAddr>	A.0
Date:	Sunday, April 23, 2017	Sheet	26 of 30

SH27\_DCDC\_5V\_3V3

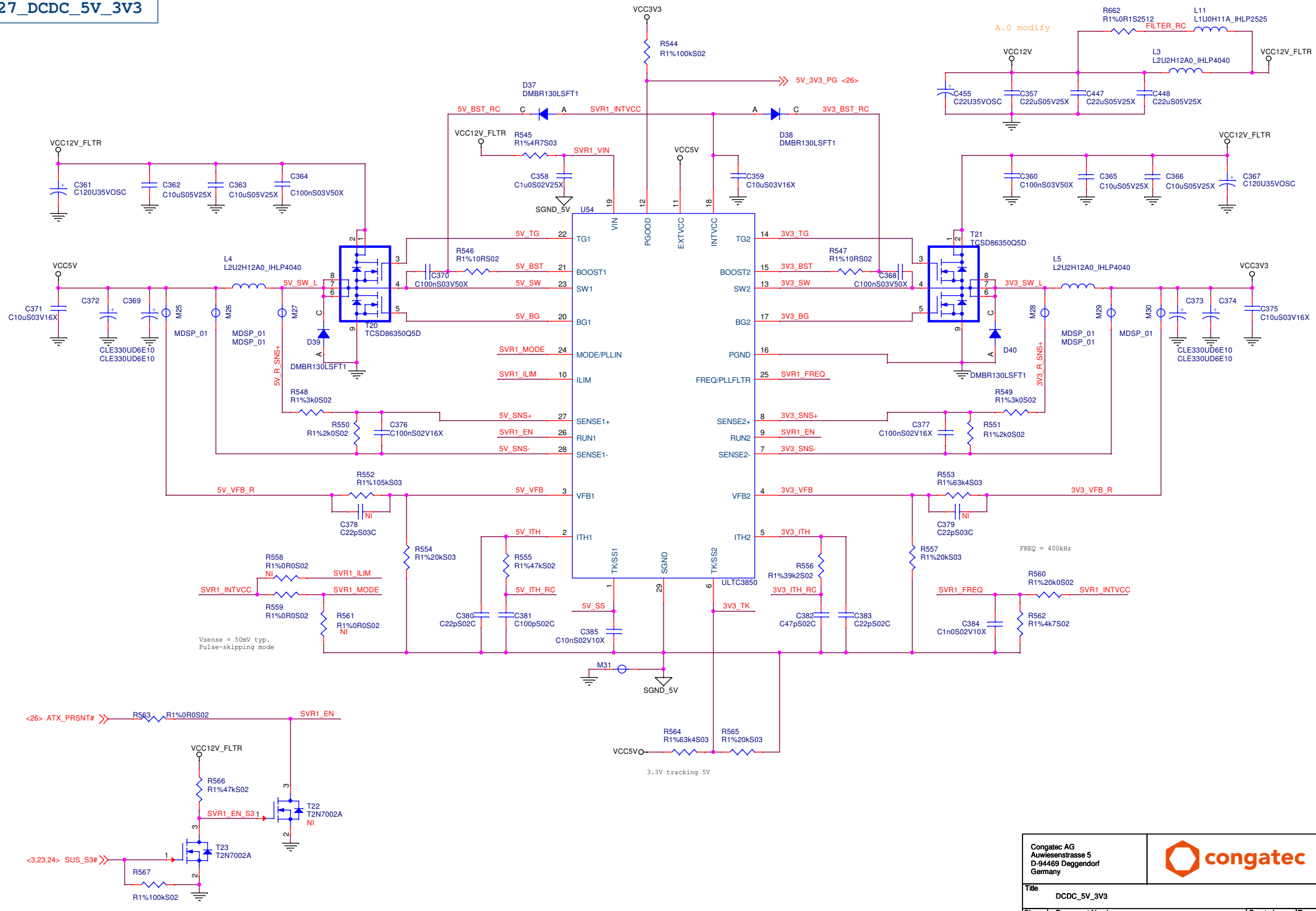

Vsense = 50mV typ.  
Pulse-skipping mode

Congatec AG Aulwiesenstrasse 5 D-94469 Deggendorf Germany			
Title DCDC_5V_3V3			
Size A3	Document Number DEVA_AD	Created -OrgAddrs-	Rev A.0
Date: Tuesday, May 09, 2017	Sheet 27	of 30	

SH28\_DCDC\_1V15\_2V5\_1V2\_1V8

Remove in IT version

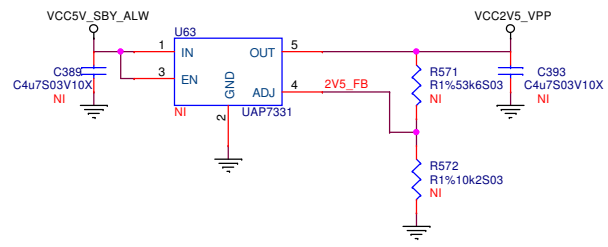

2.5 V / 0.1A

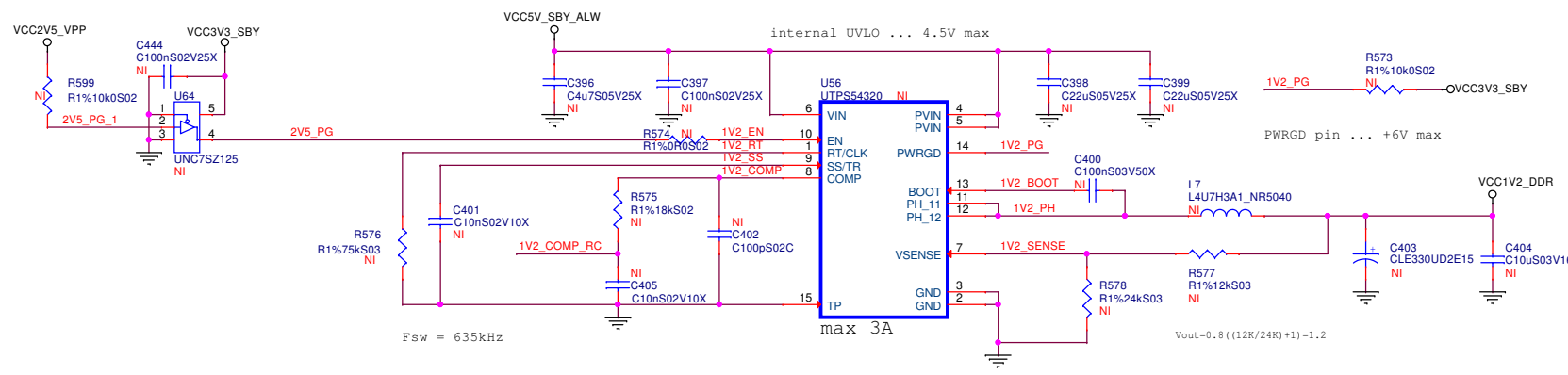

1.2 V / 0.9A

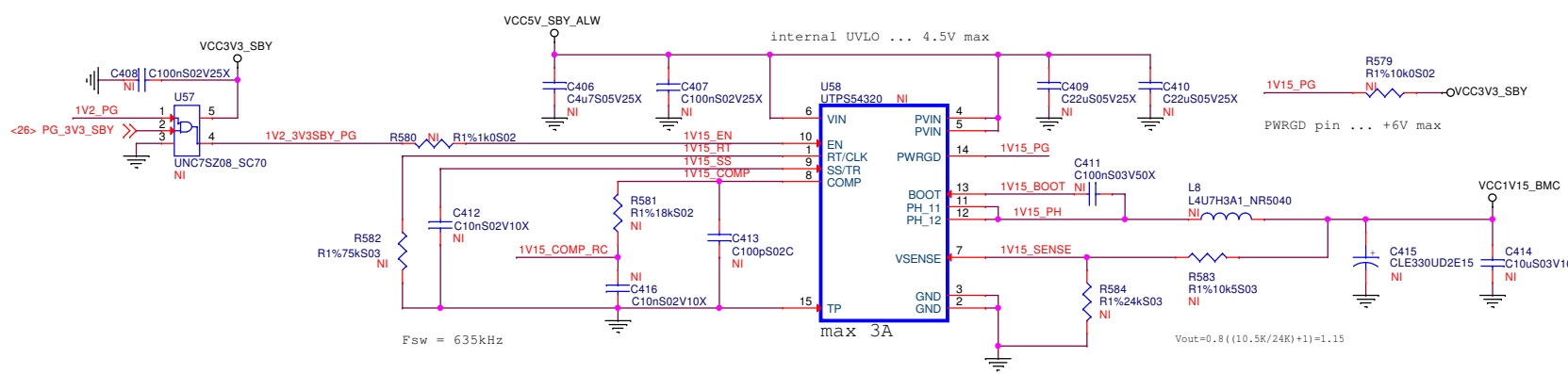

1.15 V / 0.65A

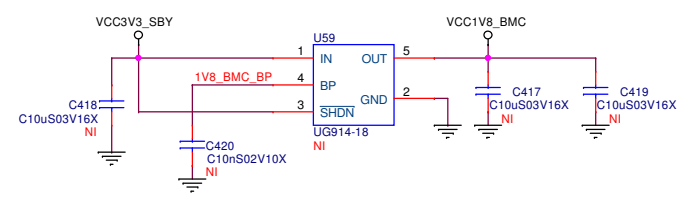

1.8 V / 0.15A

Congatec AG Auwiesenstrasse 5 D-94469 Deggendorf Germany			
Title: DCDC_1V15_2V5_1V2_1V8			
Size A3	Document Number DEVA_A0	Created -OrgAddr-	Rev A.0
Date: Sunday, April 23, 2017	Sheet 28	of 30	

SH29\_DCDC\_0V9\_1V8

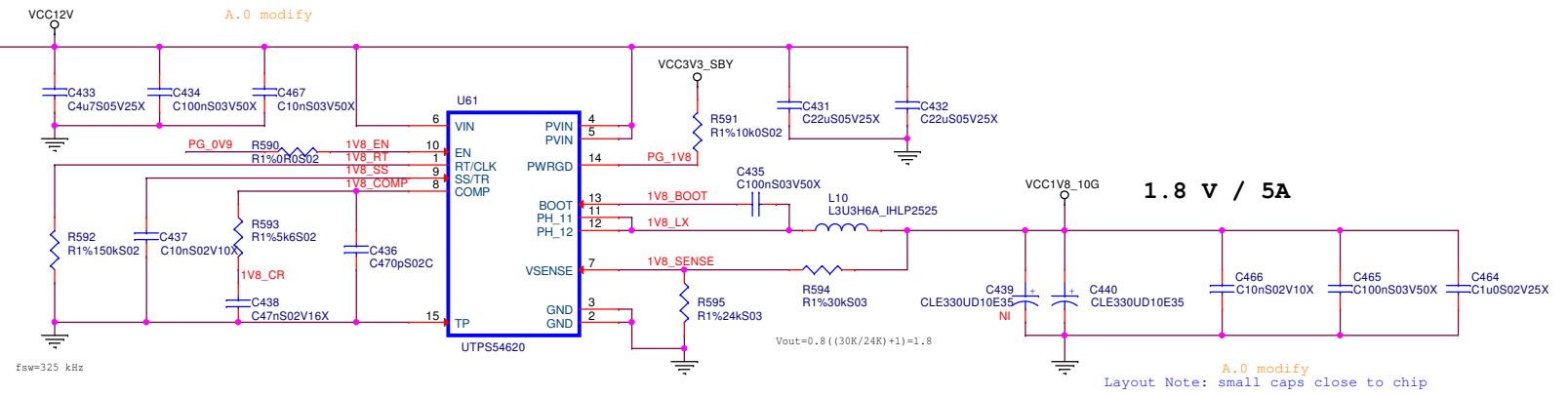
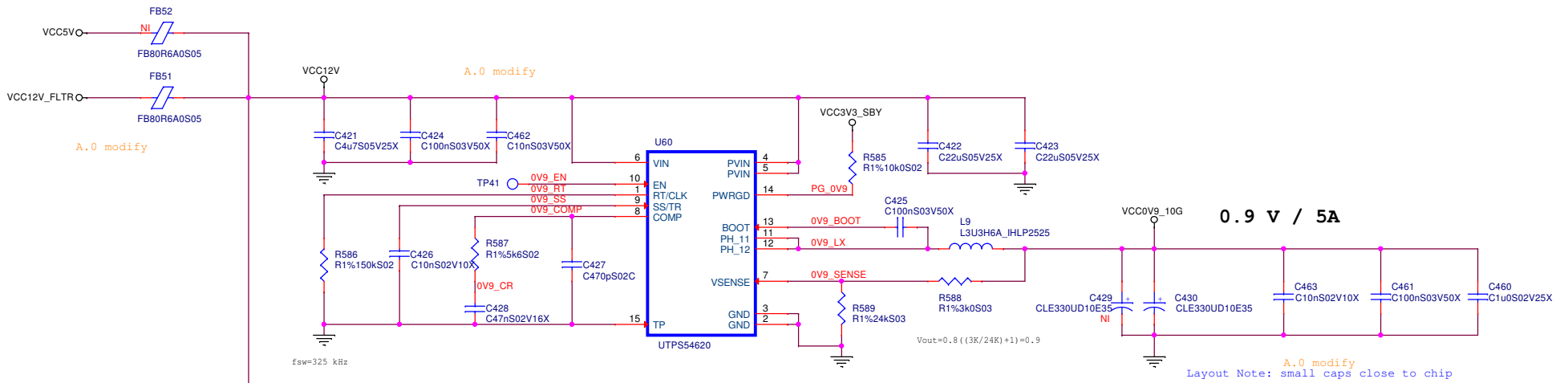

Congatec AG  
 Auwiesenstrasse 5  
 D-94469 Deggendorf  
 Germany



Title DCDC_0V9_1V8			
Size A3	Document Number DEVA_A0	Created -OrgAddr4-	Rev A.0
Date: Tuesday, May 09, 2017	Sheet 29	of 30	

# Power Delivery

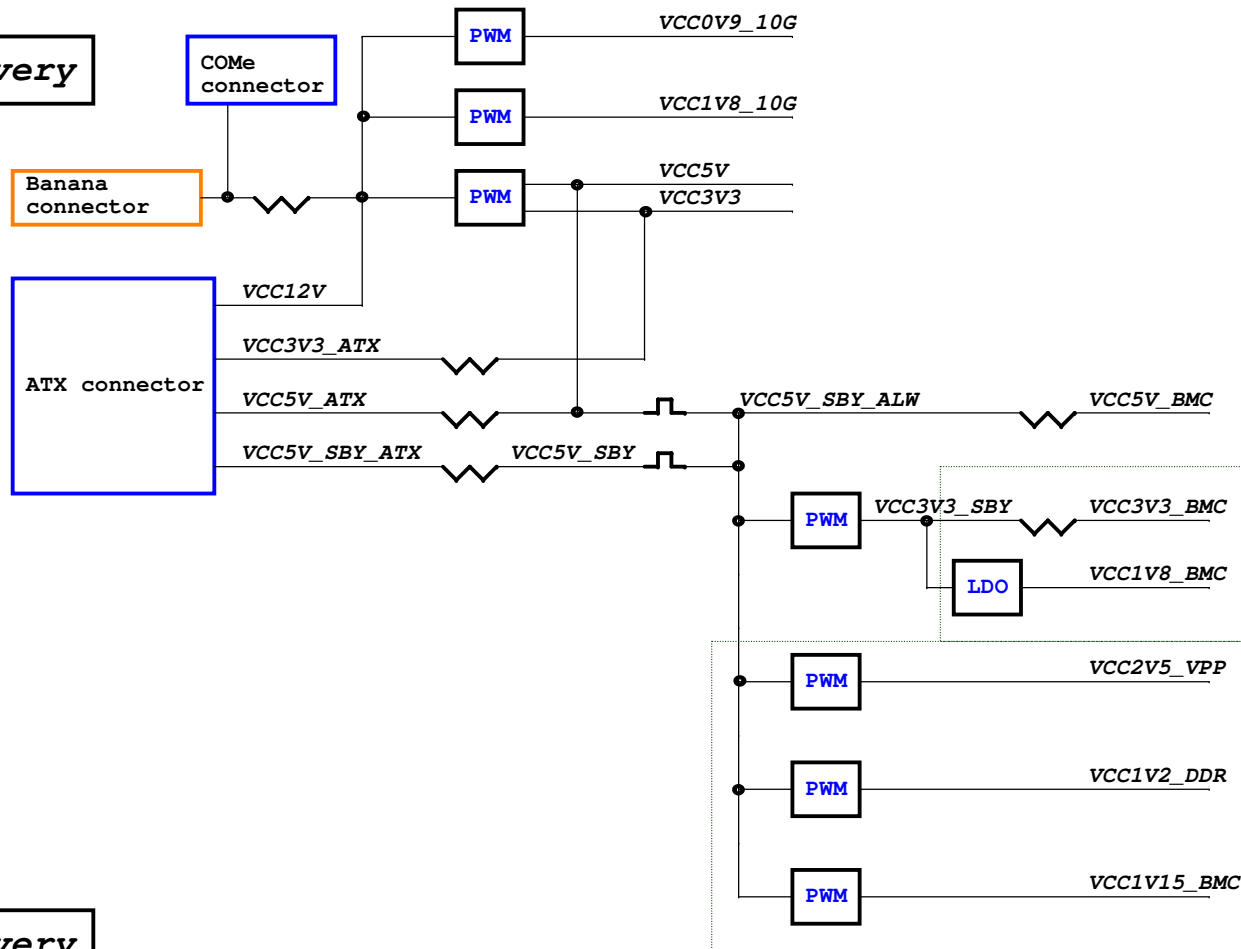

Remove in IT version

# Clock Delivery

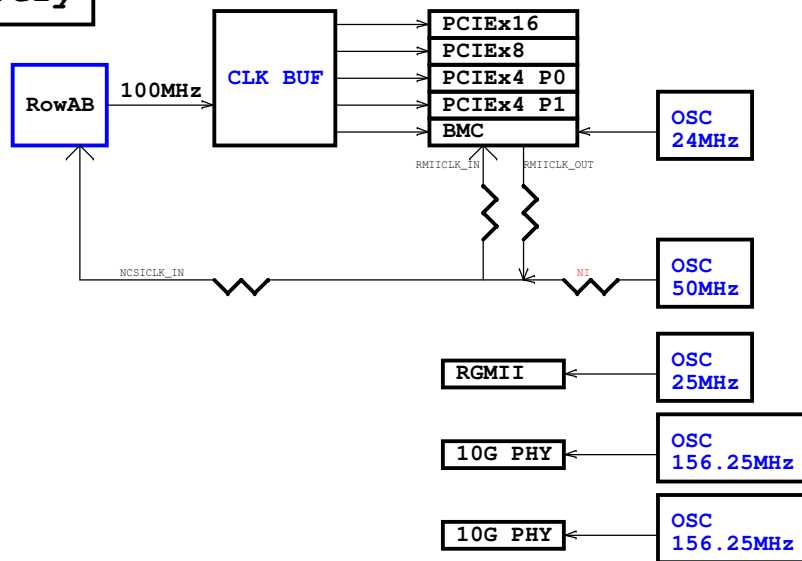

## X.1 change list

SH01 modify revision to X.1  
SH11 modify R103, R104, R105 to 51 ohm  
SH13 add R632/4.7K on "BMC\_SPICK" to "VCC3V3\_BMC"  
modify jumper X61 from 1-2 to 2-3  
SH18 mount X33  
add R635/5.6K on "LAN0\_MDC\_SCL" to GND  
add R636/5.6K on "LAN0\_MDC\_SDA" to GND  
SH19 BOM remove R390, R403  
SH20 swap "LAN2\_MDIO\_SDA" and "LAN2\_MDC\_SCL"  
mount X37  
add R633/5.6K on "LAN2\_MDC\_SCL" to GND  
add R634/5.6K on "LAN2\_MDC\_SDA" to GND  
SH21 BOM remove R454, R467

## A.0 change list

SH01 modify revision to A.0  
SH02 modify PCIE0-15 routing  
SH04 swap 10G\_LED\_SDA and 10G\_LED\_SCL  
and reserve pull-up resistors  
modify LAN23\_MICROSEL to U7.11  
add pull-up/down (default low) on 10G\_PHY\_RST\* and change U6 to OR gate  
change level shift solution for 10G\_PHY\_RST\* and LAN\*\_MICROSEL  
SH05 change D1 HDD LED to yellow  
change F3 to support 12V  
SH10 modify PCIE0-15 routing  
SH11 add D72 to prevent leakage from VGA monitor  
BOM modify R103, R104, R105 to 150 ohm  
SH12 modify test from PCIE P14 MUX to PCIE P4 MUX  
modify VCC of U27 to VCC3V3  
BOM remove X28 SD card  
SH14 add 150 ohm on RGB signal  
SH18 add U69 for level shift  
remove pull-down resistors on X33  
change X33 to 2x3 header  
connect LAN2\_MDC\_SCL/SDA to X33  
add SW1 to set address  
BOM remove D64-D67, T24-T27, R608-R615  
SH19 on X34.3 LAN0\_TX\_FAULT -> LAN0\_TX\_DIS  
on X36.3 LAN1\_TX\_FAULT -> LAN1\_TX\_DIS  
BOM add R390, R403  
BOM remove R394  
add C469-C471 and GND\_SHIELD to improve EMC  
SH20 add U70 for level shift  
remove X37 and pull-down resistors on X37  
add SW2 to set address  
BOM remove D68-D71, T28-T31, R620-R626, R631  
SH21 on X38.3 LAN2\_TX\_FAULT -> LAN2\_TX\_DIS  
on X40.3 LAN3\_TX\_FAULT -> LAN3\_TX\_DIS  
BOM add R454, R467  
BOM remove R458  
change LED power to 3.3VSB  
add C472-C475 and GND\_SHIELD to improve EMC  
SH22 modify VCC of U43 to VCC3V3\_SBY, U44 to VCC3V3\_BMC  
add D73 to prevent leakage  
remove X42 and change X41 to stackup  
SH23 add level shift chip on SPI bus between module and BMC  
SH27 add C455, R662, L11 and change L3 to improve EMC  
SH29 add C460-C467 and FB51, FB52 to improve EMC

Tune all LED's resistors

IT version modify page 6, 11-17, 18, 20, 22, 23, 26, 28

Congatec AG Auwiesenstrasse 5 D-94469 Deggendorf Germany			
Title Power/Clock Delivery			
Size A3	Document Number DEVA_A0	Created <OrgAddr>	Rev A.0
Date: Friday, May 19, 2017	Sheet 30	of 30	