

# CS-119/P2000

19" TFT-LCD Sunlight Readable Touch Panel PC  
with 6th Gen. Intel® Core™ Processor



## Key Features

- 19" TFT-LCD with Ultra High Brightness up to 1,600 nits and 1280 x 1024 (SXGA) Resolution
- Onboard Intel® 6th Generation Core™ Processor U Series (15W)
- Supports 2x DDR4 SO-DIMM Socket, up to 32 GB
- Integrated Intel® HD Graphics 520, Triple Display Support
- 2x 2.5" SATA Drive Bay, 1x mSATA, and 1x CFAST Socket
- Rich I/O (2x GbE LAN, 6x COM, 5x USB, 16x Isolated DIO)
- 2x Full-size Mini-PCIe Socket for Wireless and I/O Expansion
- Wide Range Operating Temperature -20°C to 70°C
- Designed with Aluminum Die-casting Front Frame
- True Flat IP65 Front Panel Protection
- Supports Panel / Wall / VESA Mounting
- Convertible Display System (CDS) Technology Supported
- Supports Optical Bonding



## »» Overview

CS-119/P2000 Series is a 19" TFT-LCD sunlight readable touch panel PC offering 1,600 nits ultra high brightness and 1280 x 1024 (SXGA) resolution. The system is equipped with high-performance Intel® 6th generation Core™ U series processor and provides extensive I/O including 2x GbE, 5x USB, 6x RS232/422/485, 8x DI/8x DO, 1x VGA and 1x DVI-D. It also supports 2x Mini-PCIe slot and 1x SIM socket for a variety of wireless connections, such as BT/WiFi and 3G/LTE. In addition, there are 3 types of storage devices including 2.5" SATA HDD (RAID 0/1), mSATA and CFAST. The accessible design of these storage devices allows quick data access and easy maintenance.

CS-119/P2000 Series supports Convertible Display System (CDS) technology. Comparing to regular stand-alone panel PCs, it can lower maintenance cost and reduce unplanned downtime.

For greater flexibility, CS-119/P2000 Series has PCI/PCIe expandable version and PoE/power ignition functions by additional CFM (Control Function Module). Furthermore, CS-119/P2000 Series is a truly rugged display system supporting wide range operating temperature (-20°C to 70°C), IP65 dust/waterproof front panel, wide range DC power input (9 to 48VDC) and rigorous industrial protections.

## »» Highlights



### Sunlight Readable

Providing ultra high brightness 1,600 nits and resolution up to 1280 x 1024 (SXGA), CS-119/P2000 Series is suitable for all lighting conditions including direct sunlight.



### High Performance

Powered by Intel® 6th Gen. Core™ Processor U Series, CS-119/P2000 Series Panel PC has greatly increased computing performance and power efficiency.



### Wide Temperature

CS-119/P2000 Series supports wide range operating temperature from -20°C to 70°C and is suitable for deploying in extreme and harsh environments.

## » Specifications

### Display

- LCD Size: 19" (5:4)
- Max. Resolution: 1280 x 1024
- Brightness (cd/m<sup>2</sup>): 1600
- Contrast Ratio: 1000 : 1
- LCD Color: 16.7M
- Pixel Pitch (mm): 0.294 (H) x 0.294 (V)
- Viewing Angle (H-V): 170 / 160
- Backlight MTBF: 50,000 hrs (LED Backlight)

### Touch

- Projected Capacitive Touch

### Processor System

- Onboard 6th Intel® Core™ U processors (Skylake)
  - Intel® Core™ i5-6300U processor (3M Cache, up to 3.00 GHz)
  - Intel® Core™ i3-6100U processor (3M Cache, 2.30 GHz)
  - TDP: 15 W
  - BIOS: AMI 64Mbit SPI BIOS

### Memory

- 2x DDR4 260-pin SO-DIMM socket, support up to 32 GB (2133MHz, un-buffered and non-ECC type)

### Graphics

- Intel® HD Graphics 520
- Triple display with 1x VGA, 1x DVI-D and 1x CDS interface

### Audio

- Realtek® ALC888-GR
- High Definition Audio

### I/O Interface

- 1x VGA (Up to 1920 x 1080 @ 60Hz), DB-15
- 1x DVI-D (Up to 1920 x 1080 @ 60Hz)
- 1x CDS Interface, Compact PCI Connector
- 2x GbE LAN (Support WoL, Teaming, Jumbo Frame and PXE), RJ45
  - GbE1: Intel I219LM
  - GbE2: Intel I210AT
- 2x PoE+ (with Optional CFM PoE Module)
  - Comply with IEEE 802.3at, Offers Up to 25.5W Per Port
- 6x RS-232/422/485 with Auto Flow Control (Supports 5V/12V), DB9
- 4x USB 3.0, Type-A
- 1x USB 2.0, Type-A
- 16x Isolated DIO (8x DI/8x DO), 20-Pin Terminal Block
- 1x Line-out & 1x Mic-in, Phone Jack 3.5mm
- 1x Power On/Off Switch
- 1x Reset Button
- 1x AT/ATX Switch
- 1x Remote Power On/Off Connector, 2-Pin Terminal Block
- 1x External FAN Connector, 4-Pin Terminal Block

### Expansion

- 1x CFM PoE interface
- 1x CFM IGN interface
- 1x PCI or 1x PCIe4 Expansion slot [CS-119C/P2002E]
  - Optional Riser Card: 1x PCI, 1x PCIe4
  - Support maximum dimension of add-on card (H x L): 100mm x 200mm
- 2x Full-size Mini-PCIe Socket
- 1x Universal I/O Bracket
- 1x SIM Socket
- 4x Antenna Hole

### Storage

- 2x 2.5" SATA Drive Bay, Supports RAID 0/1 (Gen3)
- 2x mSATA (One Shared by Mini-PCIe Socket) (Gen2)
- 1x CFast Socket

### Other Function

- Supports CDS Technology
- Supports CFM Technology
- Supports Instant Reboot Technology (0.2 sec)
- Supports Power Ignition Sensing (IGN)
- Support OSD Function
  - (LCD On/Off, Brightness Up, Brightness Down for CDS Display Module)
- Internal Speaker AMP 2W + 2W
- SuperCap Integrated
- Watchdog Timer:
  - Software Programmable Supports 1~255 sec. System Reset

### Power Requirement

- Supports AT/ATX Power Mode
- Power Input Voltage 9~48VDC
- One 3-pin Terminal Block Connector
- Optional Power Adapter AC/DC 24V/5A 120W

### Physical

- Dimensions (WxHxD): CS-119C/P2002: 510 x 389.3 x 88.5 mm  
CS-119C/P2002E: 510 x 389.3 x 106.5 mm
- Weight: CS-119C/P2002: 9.88 kg  
CS-119C/P2002E: 10.14 kg
- Front Panel Construction: Flat Rugged Aluminum Die-casting Bezel
- Supports Panel / Wall / Arm / VESA Mounting
- Fanless Design
- Jumper-less Design

### Environment

- Operating Temperature: -20°C to 70°C
  - (With extended temperature peripherals; Ambient with air flow According to IEC60068-2-1, IEC60068-2-2, IEC60068-2-14)
- Storage Temperature: -20°C to 70°C
- Relative Humidity: 90% RH @ 40°C (Non-condensing)
- Shock: Operating, 15 Grms, Half-sine 11 ms Duration (w/ SSD, according to IEC60068-2-27)
- Vibration: Operating, 1.5 Grms, 5-500 Hz, 3 Axes (w/ SSD, according to IEC60068-2-64)
- IP Level: IP65 Compliant Front Panel
- EMC: CE, FCC Class A

### Protection

- Reverse Power Input Protection
- Over Voltage Protection: 58V
- Over Current Protection: 15A
- ESD Protection: +/-15kV (air), +/-8kV (contact)
- Surge Protection: 3kW

### Operating System

- Windows® 10
- Windows® 8.1
- Windows® 7

### Certification

- CE
- FCC Class A

External Layout

CS-119/P2002

Front

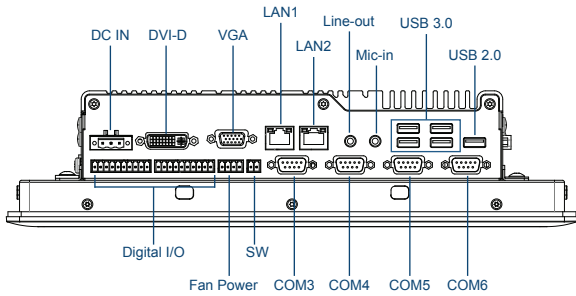

Rear

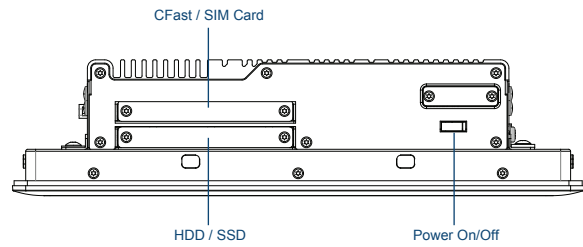

Left

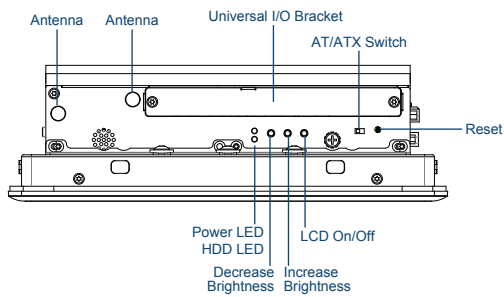

Right

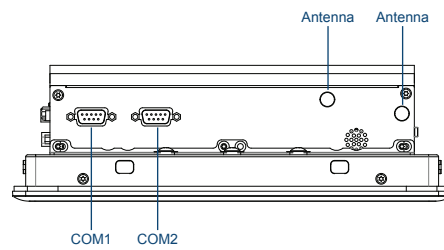

CS-119/P2002E

Front

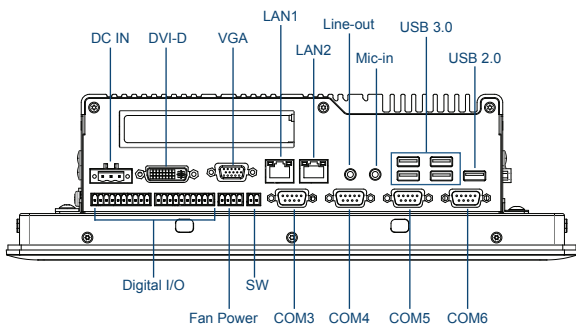

Rear

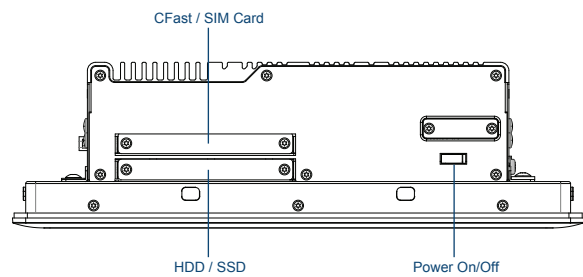

Left

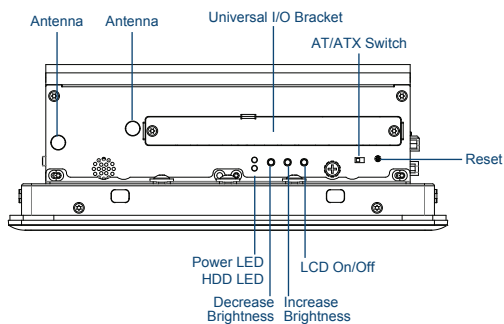

Right

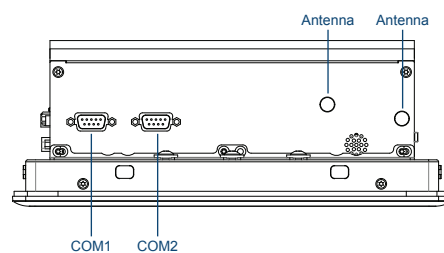

»» Dimensions

CS-119/P2002

Unit: mm

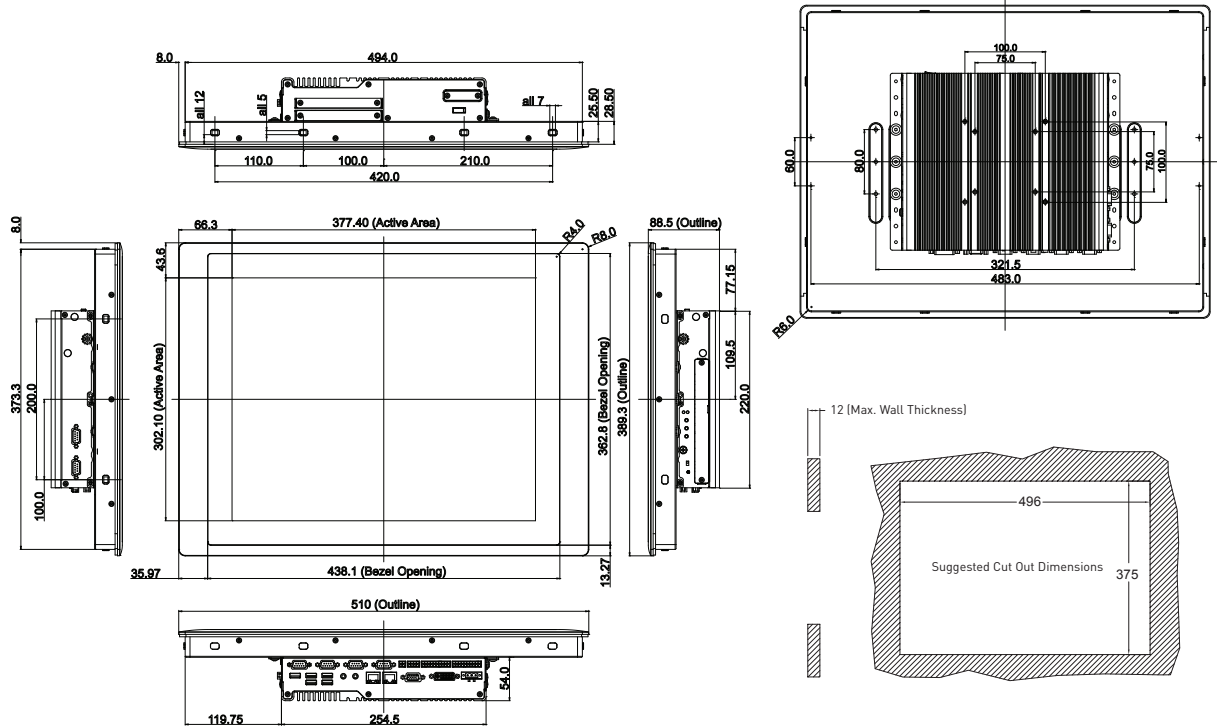

CS-119/P2002E

Unit: mm

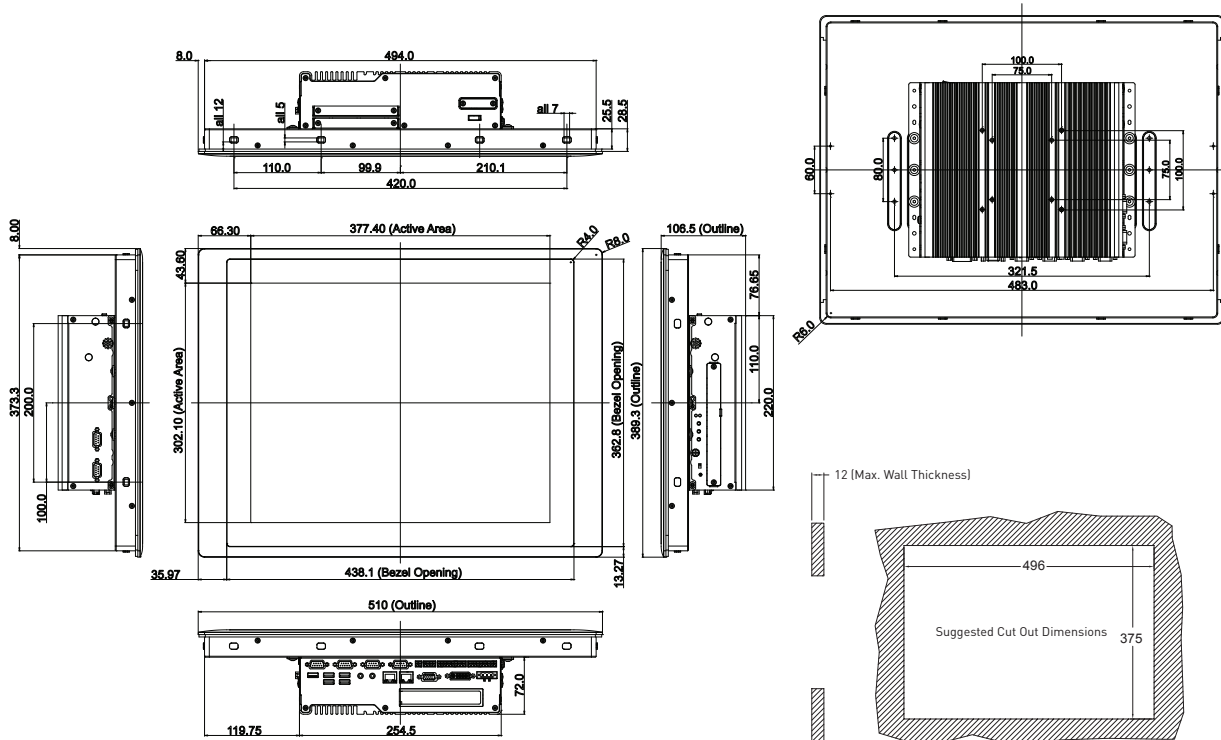

## »»» Ordering Information

### Available Models

| Model No.                       | Product Description   |
|---------------------------------|---|
| CS-119C-R10/P2002-i5-R10        | 19" TFT-LCD 1600 nits Sunlight Readable Touch Panel PC with Intel® Core™ i5-6300U Processor and P-Cap. Touch  |
| CS-119C-OB-R10/P2002-i5-R10     | 19" TFT-LCD 1600 nits Sunlight Readable Touch Panel PC with Intel® Core™ i5-6300U Processor, P-Cap. Touch and Optical Bonding                             |
| CS-119C-R10/P2002E-i5-R10       | 19" TFT-LCD 1600 nits Sunlight Readable Touch Panel PC with Intel® Core™ i5-6300U Processor, P-Cap. Touch and 1x Reserved Expansion Slot                  |
| CS-119C-OB-R10/P2002E-i5-R10    | 19" TFT-LCD 1600 nits Sunlight Readable Touch Panel PC with Intel® Core™ i5-6300U Processor, P-Cap. Touch, 1x Reserved Expansion Slot and Optical Bonding |
| CS-119C-R10/P2002E-i5-E4-R10    | 19" TFT-LCD 1600 nits Sunlight Readable Touch Panel PC with Intel® Core™ i5-6300U Processor, P-Cap. Touch and 1x PCIe x4 Expansion Slot                   |
| CS-119C-OB-R10/P2002E-i5-E4-R10 | 19" TFT-LCD 1600 nits Sunlight Readable Touch Panel PC with Intel® Core™ i5-6300U Processor, P-Cap. Touch, 1x PCIe x4 Expansion Slot and Optical Bonding  |
| CS-119C-R10/P2002E-i5-PI-R10    | 19" TFT-LCD 1600 nits Sunlight Readable Touch Panel PC with Intel® Core™ i5-6300U Processor, P-Cap. Touch and 1x PCI Expansion Slot                       |
| CS-119C-OB-R10/P2002E-i5-PI-R10 | 19" TFT-LCD 1600 nits Sunlight Readable Touch Panel PC with Intel® Core™ i5-6300U Processor, P-Cap. Touch, 1x PCI Expansion Slot and Optical Bonding      |
| CS-119C-R10/P2002-i3-R10        | 19" TFT-LCD 1600 nits Sunlight Readable Touch Panel PC with Intel® Core™ i3-6100U Processor and P-Cap. Touch  |
| CS-119C-OB-R10/P2002-i3-R10     | 19" TFT-LCD 1600 nits Sunlight Readable Touch Panel PC with Intel® Core™ i3-6100U Processor, P-Cap. Touch and Optical Bonding                             |
| CS-119C-R10/P2002E-i3-R10       | 19" TFT-LCD 1600 nits Sunlight Readable Touch Panel PC with Intel® Core™ i3-6100U Processor, P-Cap. Touch and 1x Reserved Expansion Slot                  |
| CS-119C-OB-R10/P2002E-i3-R10    | 19" TFT-LCD 1600 nits Sunlight Readable Touch Panel PC with Intel® Core™ i3-6100U Processor, P-Cap. Touch, 1x Reserved Expansion Slot and Optical Bonding |
| CS-119C-R10/P2002E-i3-E4-R10    | 19" TFT-LCD 1600 nits Sunlight Readable Touch Panel PC with Intel® Core™ i3-6100U Processor, P-Cap. Touch and 1x PCIe x4 Expansion Slot                   |
| CS-119C-OB-R10/P2002E-i3-E4-R10 | 19" TFT-LCD 1600 nits Sunlight Readable Touch Panel PC with Intel® Core™ i3-6100U Processor, P-Cap. Touch, 1x PCIe x4 Expansion Slot and Optical Bonding  |
| CS-119C-R10/P2002E-i3-PI-R10    | 19" TFT-LCD 1600 nits Sunlight Readable Touch Panel PC with Intel® Core™ i3-6100U Processor, P-Cap. Touch and 1x PCI Expansion Slot                       |
| CS-119C-OB-R10/P2002E-i3-PI-R10 | 19" TFT-LCD 1600 nits Sunlight Readable Touch Panel PC with Intel® Core™ i3-6100U Processor, P-Cap. Touch, 1x PCI Expansion Slot and Optical Bonding      |

## »»» Ordering Information

### Package Checklist

- Panel PC x 1
- Utility DVD Driver x 1
- Power Terminal Block Connector x 1
- Fan Terminal Block Connector x 1
- DIO Terminal Block Connector x 2
- Power On/Off Terminal Block Connector x 1
- Screw Pack x 1
- Panel Mounting Kit x 1

### Optional Accessories

| Model No.     | Description   |
|---------------|---|
| GST120A24-CIN | Adapter AC/DC 24V 5A 120W, GST120A24-CIN, wide temp (-30°C ~ +70°C), level VI |
| SL2-SL3       | US 2 heads power cord, US B type to IEC C13,SVT 18AWG/3C Black 1.8M           |
| SL6-SL3       | EU 2 heads power cord, EU G type to IEC C13,H05VV-F 0.75mm2/3G Black 1.8M     |
| QP026-SL3     | UK 2 heads power cord, UK I type to IEC C13,H05VV-F 0.75mm2/3G Black 1.8M     |

### Optional Modules

| Model No.              | Description  |
|------------------------|--|
| CFM-IGN100             | CFM Module with Power Ignition Sensing Control Function, 12V/24V Selectable (41 x 35 mm)             |
| CFM-PoE100             | PoE Control Function Module, Individual Port 25.5W (50 x 44 x 15 mm) <i>(For CS-100/P2002 only)</i>  |
| CFM-PoE101             | PoE Control Function Module, Individual Port 25.5W (50 x 44 x 33 mm) <i>(For CS-100/P2002E only)</i> |
| MEC-COM-M212/UB0503    | Mini-PCle Module with 2x COM Ports, 2x Universal Brackets (154 x 17 mm)                              |
| MEC-COM-M334/UB0504    | Mini-PCle Module with 4x RS-232/422/485 Serial Ports,1x Universal Bracket (154 x 17 mm)              |
| MEC-LAN-M002-R1/UB0511 | Mini-PCle Module with 2x LAN Ports, 1x Universal Bracket (154 x 17 mm)                               |
| MEC-USB-M002/UB0514    | Mini-PCle Module with 2x USB 3.0 Ports, 1x Universal Bracket (154 x 17 mm)                           |
| RC-E4-01               | Riser Card with 1x PCIe4 Slot <i>(For CS-100/P2002E only)</i>  |
| RC-PI-01               | Riser Card with 1x PCI Slot <i>(For CS-100/P2002E only)</i>  |