

## **VDX-6315RD / VDX-6315RD-512**

**DM&P Vortex86DX 800MHz**

**Tiny CPU Module**

**with 4S/2USB/LAN/2GPIO/PWMx24**

**256MB DDR2 Onboard**

**User's Manual**

(Revision 1.1 A)

## ● Copyright

The information in this manual is subject to change without notice for continuous improvement in the product. All rights are reserved. The manufacturer assumes no responsibility for any inaccuracies that may be contained in this document and makes no commitment to update or to keep current information contained in this manual.

No part of this manual may be reproduced, copied, translated or transmitted, in whole or in part, in any form or by any means without the prior written permission of the ICOP Technology Inc.

©Copyright 2008 ICOP Technology Inc.

Manual No. IUM6315D000-01 Ver.1.0A ● March, 2011

Manual No. IUM6315RD000-01 Ver.1.1A ● October, 2014

## ● Trademarks Acknowledgment

Vortex86DX™ is the registered trademark of ICOP Technology Inc.

Other brand names or product names appearing in this document are the properties and registered trademarks of their respective owners. All names mentioned herewith are served for identification purpose only.

# Table of Contents

Table of Contents .....	iii
Chapter 1 Introduction.....	1
1.1 Packing List.....	1
1.2 Product Description .....	1
1.3 Specifications .....	3
1.4 Board Dimension.....	4
Chapter 2 Installation.....	5
2.1 Board Outline .....	5
2.2 Connectors & Jumpers Location .....	6
2.3 Connectors & Jumpers Summary.....	8
2.4 Pin Assignments & Jumper Settings.....	9
2.5 System Mapping.....	16
2.6 Watchdog Timer .....	19
2.7 GPIO .....	20
2.8 SPI flash.....	21
2.9 PWM .....	22
3.0 IDE to SD .....	23
Chapter 3 Driver Installation.....	24
Appendix .....	25
A. TCP/IP library for DOS real mode .....	25
B. BIOS Default Setting .....	26
Warranty.....	27

**This page is blank**

# Chapter 1

## Introduction

### 1.1 Packing List

Product Name	Package
VDX-6315RD & VDX-6315RD-512	<ul style="list-style-type: none"><li>● Embedded Vortex86DX CPU All-in-One Board</li><li>● Manual &amp; Drivers CD x 1</li><li>● RS232 cable x 4</li><li>● PRINT cable x1</li><li>● IDE cable x 1</li><li>● USB cable x 1 (USB port x 2)</li><li>● GPIO cable x 2</li><li>● PS/2 Keyboard cable x 1</li></ul>

## 1.2 Product Description

The VDX-6315RD family of low-power x86 embedded controller is designed to meet Tiny specification, and integrated with the following features.

- 800MHz Vortex86DX System-On-Chip
- 256/ 512MB DDR2 system memory
- Enhanced IDE (UltraDMA-100/66/33)
- 10/100Mbps Ethernet
- 2 USB 2.0 (host)
- Up to 4 serial ports
- Parallel port
- 16-bit GPIO x2
- x-ISA bus
- RS-485 with Auto Direction
- 2 watchdog timer
- PWM 24~32 channels
- AMI BIOS
- 4MB SPI flash
- Single voltage +5V DC
- Support extended operating temperature range of -20°C to +70°C

The VDX-6315RD Tiny family of embedded controller is designed with backward compatibility in mind, to provide migration path for projects facing end-of-life challenges with their existing x86 based Tiny controller. The VDX-6315RD family of controller is designed as a plug in replacement, with backward compatibility to support legacy software to help extend existing product life cycle without heavy re-engineering.

VDX-6315RD is suitable for broad range of data-acquisition, Industrial automation, Process control, Automotive controller, AVL, Intelligent Vehicle management device, Medical device, Human machine interface, Robotics, machinery control And more...application that required small footprint, low-power and low-cost hardware with open industry standard such as Tiny.

## 1.3 Specifications

Features	VDX-6315RD
CPU	DM&P SoC CPU Vortex86DX- 800MHz Real Time Clock with Lithium Battery Backup
Cache	L1:16K I-Cache, 16K D-Cache, L2 Cache 128KB
BIOS	AMI BIOS
Bus Interface	16-bit x-ISA interface
System Memory	256/ 512MB DDR2 Onboard
Watchdog Timer	Software programmable from 30.5 us to 512 seconds x2 sets(Watchdog 1 fully compatible with M6117D)
LAN	Integrated 10/100M Ethernet
I/O Interface	<ul style="list-style-type: none"> <li>● Enhanced IDE port (UltraDMA-100/66/33) x1</li> <li>● RS-232 port x3</li> <li>● RS-232/422/485 port x1 (RS485 with Auto Direction)</li> <li>● Parallel port x1</li> <li>● USB port x2 (USB 2.0 version)</li> <li>● 16-bit GPIO port x2</li> <li>● 10/100Mbps Ethernet port x1</li> </ul>
Connectors	<ul style="list-style-type: none"> <li>● 2.00 mm Ø 44-pin box header for IDE x1</li> <li>● 2.00 mm Ø 26-pin box header for Print x1</li> <li>● 2.00 mm Ø 20-pin box header for 16-bit GPIO x2</li> <li>● 2.00 mm Ø 10-pin box header for RS-232 x4</li> <li>● 2.00 mm Ø 10-pin box header for USB x1</li> <li>● 2.00 mm Ø 2-pin header for Reset x1</li> <li>● 2.00 mm Ø 2-pin header for Console Redirection x1</li> <li>● 2.54 mm Ø 3-pin header for RS-485 x1</li> <li>● 2.54 mm Ø 5-pin box header for keyboard x1</li> <li>● 2.54 mm Ø 2-pin header for LINK LED x1</li> <li>● 2.54 mm Ø 2-pin header for TX/RX LED x1</li> <li>● 1.25mm Ø 6-pin Wafer for JTAG x1</li> <li>● External RJ-45 connector for Ethernet x1</li> </ul>
Flash Disk Support	<ul style="list-style-type: none"> <li>● Onboard 4MB SPI Flash Disk (Driver: A)</li> <li>● 44-pin IDE Flash Disk( EmbedDisk 16MB or above)</li> <li>● 44-pin IDE to Micro SD (Optional)</li> </ul>
PWM	24~32 Channels
SRAM support	512KB (Optional)
Power Requirement	Single Voltage +5V @ 400mA
Dimension	100mm X 66mm (3.94 x2.6 inches)
Weight	63g
Operating Temperature	-20°C ~ +70°C -40°C ~ +85°C (Optional)





# Chapter 2

## Installation

### 2.1 Board Outline

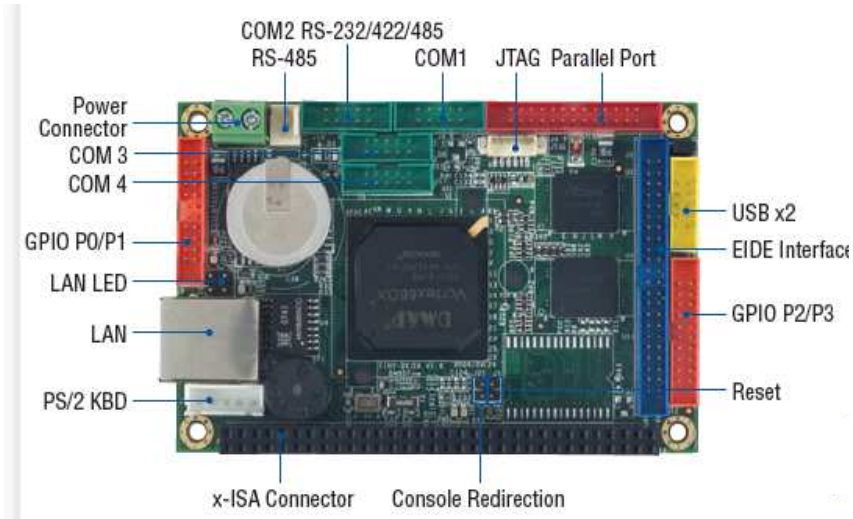

#### Note:

1. VGA function support, ICOP-2720, via x-ISA Interface  
ICOP-2720: <http://www.icop.com.tw/en/product/Tiny-Module-ICOP-2720/ICOP-2720.html>
2. COM2 RS232/422/485 is selected by BIOS setting
3. J21 Default setting of JTAG Has to be Disable: Pin 1 & Pin 2 short
4. VDX-6315RD-512 is optional

## 2.2 Connectors & Jumpers Location

### Connectors

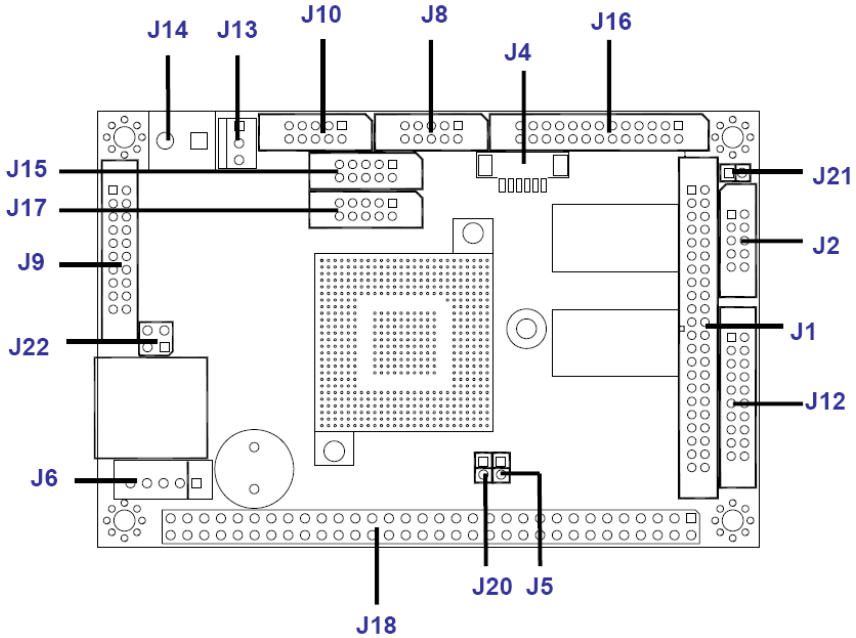

## Jumpers & LEDs

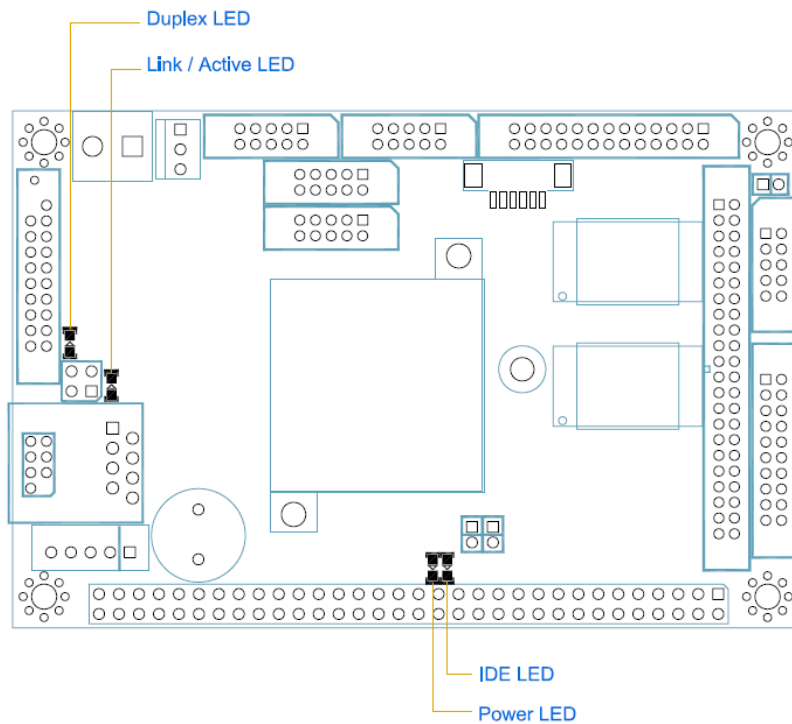

## 2.3 Connectors & Jumpers Summary

Summary Table

Nbr	Description	Type of Connections	Pin nbrs.
J1	IDE	Box Header, 2,0Ø ,22x2	44-pin
J2	USB	Box Header,2,0Ø , 5x2	10-pin
J3	LAN	RJ45 Connector	8-pin
J4	JTAG	Wafer, 1,25Ø , 6x1	6-pin
J5	Reset	Pin Header, 2,54Ø,1x2	2-pin
J6	PS/2 Keyboard	Box Header, 2,54Ø,1x5	5-pin
J8	COM1	Box Header, 2,0Ø 5x2	10-pin
J9	GPIO (Port 0/1 or PWMx16)	Box Header, 2,0Ø ,10x2	20-pin
J10	COM2(RS232/422/485)	Box Header, 2,54Ø 5x2	10-pin
J12	GPIO (Port2/3 or PWMx8)	Box Header, 2,0Ø ,10x2	20-pin
J13	RS-485	Molex Header,2,54Ø,3x1	3-pin
J14	Power Connector	Terminal Block 5.0Ø,2x1	2-pin
J15	COM3	Box Header, 2,0Ø 5x2	10-pin
J16	PRINT	Box Header, 2,0Ø ,13x2	26-pin
J17	COM4	Box Header, 2,0Ø 5x2	10-pin
J18	x-ISA Connector – 64 pin	Box Header, 2,54Ø 32x2	64-pin
J20	Console Redirection	Pin Header, 2,0Ø,1x2	2-pin
J21	JTAG Disable (Default setting)	Pin Header, 2,54Ø,1x2	2-pin
J22	LAN LED	Pin Header, 2,54Ø,2x2	4-pin
PWR-LED	Power Active LED (Red)	LED-SMD	
IDE-LED	IDE Active LED (Green )	LED-SMD	
LED 3	LAN Link/Active LED (Green)	LED-SMD	
LED 4	LAN Duplex LED ( Yellow )	LED-SMD	
SP1	BUZZER		

## 2.4 Pin Assignments & Jumper Settings

### J1: IDE (44 Pins)

Pin #	Signal Name	Pin #	Signal Name
1	IDERST	2	GND
3	IDED7	4	IDED8
5	IDED6	6	IDED9
7	IDED5	8	IDED10
9	IDED4	10	IDED11
11	IDED3	12	IDED12
13	IDED2	14	IDED13
15	IDED1	16	IDED14
17	IDED0	18	IDED15
19	GND	20	NC
21	IDEREQ	22	GND
23	IDEIOW	24	GND
25	IDEIOR	26	GND
27	ICHRDY	28	GND
29	IDEACK	30	GND
31	IDEINT	32	NC
33	IDESA1	34	IDECBLID
35	IDESA0	36	IDESA2
37	IDECS-0	38	IDECS1
39	IDELED	40	GND
41	VCC	42	VCC
43	GND	44	NC

### J2: USB

Pin #	Signal Name	Pin #	Signal Name
1	VCC	2	VCC
3	LUSBD3-	4	LUSBD2-
5	LUSBD3+	6	LUSBD2+
7	GND	8	GND
9	GGND	10	GGND

## J4: JTAG

Pin #	Signal Name	Pin #	Signal Name
1	VCC	2	GND
3	TCK	4	TDO
5	TDI	6	TMS

## J5: RESET

Pin #	Signal Name	Pin #	Signal Name
1	RST_SW	2	GND

## J6: PS/2 Keyboard

Pin #	Signal Name	Pin #	Signal Name
1	KBCLK	2	KBDAT
3	NC	4	GND
5	VCC		

## J8: COM1 (Optional: TTL / GPIO-P4 / PWMx8)

Pin #	Signal Name	Pin #	Signal Name
1	DCD1	2	RXD1
3	TXD1	4	DTR1
5	GND	6	DSR1
7	RTS1	8	CTS1
9	RI1	10	NC

### J9: GPIO (Port 0 / Port 1/PWMx16)

Pin #	Signal Name	Pin #	Signal Name
1	GND	2	VCC
3	GP00	4	GP10
5	GP01	6	GP11
7	GP02	8	GP12
9	GP03	10	GP13
11	GP04	12	GP14
13	GP05	14	GP15
15	GP06	16	GP16
17	GP07	18	GP17
19	VCC	20	GND

### J10: COM2 RS232 / 422 / 485 (Optional: TTL)

Pin #	Signal Name	Pin #	Signal Name
1	DCD2 / <b>422TX-</b> / RS485-	2	RXD2 / <b>422TX+</b> / S485+
3	TXD2 / <b>422RX+</b>	4	DTR2 / <b>422RX-</b>
5	GND	6	DSR2
7	RTS2	8	CTS2
9	RI2	10	NC

## J12: GPIO (Port 2 / 3 /PWMx8)

Pin #	Signal Name	Pin #	Signal Name
1	GND	2	VCC
3	GP20	4	SPICS / GP30
5	GP21	6	SPICLK / GP31
7	GP22	8	SPID0 / GP32
9	GP23	10	SPIDI / GP33
11	GP24	12	GP34
13	GP25/RS232	14	GP35
15	GP26/RS422	16	GP36
17	GP27/RS485	18	GP37
19	VCC	20	GND

\*If you Enable 4M SPI flash Disk in the BIOS setting, you cannot use GP30~GP33 Pins.

\*\*If you Enable RS-232/422/485 in the BIOS setting, you cannot use GP25~GP27 Pins.

## J13: RS-485 (Auto direction)

Pin #	Signal Name
1	RS485+
2	RS485-
3	GND

## J14: Power Connector (Terminal Block 5.0mm)

Pin #	Signal Name
1	+5V
2	GND

## J15: COM3 (Optional: TTL)

Pin #	Signal Name	Pin #	Signal Name
1	DCD3	2	RXD3
3	TXD3	4	DTR3
5	GND	6	DSR3
7	RTS3	8	CTS3
9	RI3	10	NC



## J16: PRINT

Pin #	Signal Name	Pin #	Signal Name
1	STB-	14	AFD-
2	PD0	15	ERR-
3	PD1	16	INIT-
4	PD2	17	SLIN-
5	PD3	18	GND
6	PD4	19	GND
7	PD5	20	GND
8	PD6	21	GND
9	PD7	22	GND
10	ACK-	23	GND
11	BUSY	24	GND
12	PE	25	GND
13	SLCT	26	NC

## J17: COM4 (Optional: TTL)

Pin #	Signal Name	Pin #	Signal Name
1	DCD4	2	RXD4
3	TXD4	4	DTR4
5	GND	6	DSR4
7	RTS4	8	CTS4
9	RI4	10	NC

## J18: x-ISA Connector – 64pin

Pin #	Signal Name	Pin #	Signal Name
1	GND	2	SBHE
3	RSTDRV	4	SD7
5	VCC	6	SD6
7	SD8	8	SD5
9	SD9	10	SD4
11	SD10	12	SD3
13	SD11	14	SD2
15	SD12	16	SD1
17	SD13	18	SD0
19	GND	20	IOCHRDY
21	SMEMW	22	AEN
23	SMEMR	24	SA19
25	IOW	26	SA18
27	IOR	28	SA17
29	SD14	30	SA16
31	SD15	32	SA15
33	MEMCS16	34	SA14
35	ICOS16	36	SA13
37	REFRESH	38	SA12
39	SYSCLK	40	SA11
41	IRQ7	42	SA10
43	IRQ6	44	SA9
45	IRQ5	46	SA8
47	IRQ4	48	SA7
49	IRQ3	50	SA6
51	IRQ10	52	SA5
53	IRQ11	54	SA4
55	BALE	56	SA3
57	VCC	58	SA2
59	OSC	60	SA1
61	GND	62	SA0
63	IRQ12	64	IRQ14

## J20: Console Redirection (Pin 1 & Pin 2 short)

Pin #	Signal Name	Pin #	Signal Name
1	Console_Red	2	GND

## J21: JTAG Disable (Default setting: Pin 1 & Pin 2 short)

Pin #	Signal Name	Pin #	Signal Name
1	GND	2	JTAG Disable

\*CPU module will not function if this jumper is not short

## J22: LAN LED

Pin #	Signal Name	Pin #	Signal Name
1	VCC	2	Link / Active
3	VCC	4	TX / RX

## 2.5 System Mapping

### System Mapping

#### Memory Mapping

Address	Description	Usage
0000:0000-9000:FFFF	System RAM	*
A000:0000-A000:FFFF	EGA/VGA Video Memory	
B000:0000-B000:7FFF	MDA RAM, Hercules graphics display RAM	
B000:8000-B000:FFFF	CGA display RAM	
C000:0000-C000:7FFF	EGA/VGA BIOS ROM	
C000:8000-C000:FFFF	Boot ROM enable.	*
D000:0000-D000:FFFF	Expansion ROM space.	
E000:0000-E000:FFFF	USB Legacy SCSI ROM space.	*
F000:0000-F000:FFFF	Motherboard BIOS	*

#### I/O Mapping

I/O Address	Owner	Usage
0000h - 000Fh	DMA 8237-1	*
0010h - 0017h	COM 9	
0018h - 001Fh	Empty	
0020h - 0021h	PIC 8259-1	*
0022h - 0023h	6117D configuration port	*
0024h - 002Dh	Empty	
002Eh - 002Fh	Forward to LPC BUS	*
0030h - 003Fh	Empty	
0040h - 0043h	Timer counter 8254	*
0044h - 0047h	Empty	
0048h - 004Bh	PWM counter 8254	*
004Ch - 004Dh	Empty	
004Eh - 004Fh	Forward to LPC BUS	*
0050h - 005Fh	Empty	
0060h	Keyboard data port	*
0061h	Port B + NMI control port	*
0062h - 0063h	8051 download 4K address counter	*
0064h	Keyboard status port	*
0065h	WatchDog0 reload counter	*

0066h	8051 download 8bit data port	*
0067h	WatchDog1 reload counter	*
0068h - 006Dh	WatchDog1 control register	*
006Eh - 006Fh	Empty	
0070h - 0071h	CMOS RAM port	*
0072h - 0075h	MTBF counter	*
0076h - 0077h	Empty	
0078h - 007Ch	GPIO port 0,1,2,3,4 default setup	*
007Dh - 007Fh	Empty	
0080h - 008Fh	DMA page register	*
0090h - 0091h	Empty	
0092h	System control register	*
0093h - 0097h	Empty	
0098h - 009Ch	GPIO direction control	*
00A0h - 00A1h	PIC 8259-2	*
00A2h - 00BFh	Empty	
00C0h - 00DFh	DMA 8237-2	*
00E0h - 00FFh	Empty	
0100h - 0101h	GPCS1 default setting address	*
0170h - 0177h	IDE1 (IRQ 15)	
01F0h - 01F7h	IDE0 (IRQ 14)	*
0220h - 0227h	COM8 Forward to LPC BUS	
0228h - 022Fh	COM7 Forward to LPC BUS	
0238h - 023Fh	COM6 Forward to LPC BUS	
0278h - 027Fh	Printer port (IRQ 7, DMA 0)	*
02E8h - 02EFh	COM4 (IRQ 11)	*
02F8h - 02FFh	COM2 (IRQ 3)	*
0338h - 033Fh	COM5 Forward to LPC BUS	
0376h	IDE1 ATAPI device control write only register	*
03E8h - 03EFh	COM3 (IRQ 10)	*
03F0h - 03F7h	Floppy Disk (IRQ 6, DMA 2)	
03F6h	IDE0 ATAPI device control write only register	*
03F8h - 03FFh	COM1 (IRQ 4)	*
0480h - 048Fh	DMA High page register	*
0490h - 0499h	Instruction counter register	*
04D0h - 04D1h	8259 Edge,/ level control register	*
0CF8h - 0CFFh	PCI configuration port	*
D400h - D4FFh	on board LAN	*
FC00h - FC05h	SPI Flash BIOS control register	*
FC08h - FC0Dh	External SPI BUS control register ( output pin configurable GPIO3[0-3] )	*

<b>IRQ Mapping</b>		
<b>IRQ#</b>	<b>Description</b>	<b>Usage</b>
IRQ0	System Timer	*
IRQ1	Keyboard Controller	*
IRQ2	Cascade for IRQ8 - 15	
IRQ3	Serial Port 2	*
IRQ4	Serial Port 1	*
IRQ5	USB	*
IRQ6	Unassigned	
IRQ7	Parallel Port	*
IRQ8	Real Time Clock	*
IRQ9	USB	*
IRQ10	Serial Port 3	*
IRQ11	Serial Port 4	*
IRQ12	Mouse	*
IRQ13	Math Coprocessor	*
IRQ14	Hard Disk Controller#1	*
IRQ15	Ethernet 10/100M LAN	*

<b>DMA Mapping</b>		
<b>DMA#</b>	<b>Description</b>	<b>Usage</b>
DMA0		
DMA1		
DMA2	Floppy Disk Controller	
DMA3		
DMA5		
DMA6		
DMA7		

## 2.6 Watchdog Timer

There are two watchdog timers in Vortex86SX/DX CPU. One is compatible with M6117D watchdog timer and the other is new. The M6117D compatible watchdog timer is called WDT0 and new one is called WDT1.

We also provide DOS, Linux and WinCE example for your reference. For more technical support, please visit: <http://www.dmp.com.tw/tech> or download the PDF file:

<http://www.dmp.com.tw/tech/vortex86dx/>

## 2.7 GPIO (General Purpose Input / Output)

40 GPIO pins are provided by the Vortex86SX/DX for general usage in the system. All GPIO pins are independent and can be configured as inputs or outputs, with or without pull-up/pull-down resistors.

We also offer DOS, Linux and WinCE example for your reference. For more technical support, please visit: <http://www.dmp.com.tw/tech> or download the PDF file:

<http://www.dmp.com.tw/tech/vortex86dx/>



## 2.8 SPI flash (Serial Peripheral Interface)

As SPI Flash (Serial Peripheral Interface) offers many benefits including: reduced controller pin count, smaller and simpler PCBs, reduced switching noise, less power consumption, and lower system cost

Many of users may consider using a formatted SPI flash to boot for the system or emulate SPI flash as Floppy (A: Driver or B: Driver). Then you must know how to set for this condition in CMOS Setup and boot up under DOS 6.22, X-DOS, DR-DOS and Free DOS.

For more technical support, please visit: <http://www.dmp.com.tw/tech> or download the PDF file: <http://www.dmp.com.tw/tech/vortex86dx/>

## 2.9 PWM (Pulse-width modulation)

Pulse-width modulation (PWM) of a signal or power source involves the modulation of its duty cycle, to either convey information over a communications channel or control the amount of power sent to a load.

The popular applications of pulse width modulation are in speed control of electric motors, volume control of Class D audio amplifiers or brightness control of light sources and many other power electronics applications.

The Vortex86DX SoC integrated 32 channels of PWM interface enabling the Automation, robotic industry to a New Age x86 SoC platform and we also offer the sample code of PWM which will guide the engineer to control the PWM functionality smoothly.

For more inquire of this sample code that please contact our sales team or mail to:

[info@icop.com.tw](mailto:info@icop.com.tw)

## 3.0 IDE to SD (Micro-SD)

Vortex86DX SoC also built-in simulation circuit to adapt SD to IDE in order to allow your system to recognize Micro-SD card as C: or D: Drive

**SD-1917:** 44 pins IDE to SD Adapter is an ideal solution for industrial PC or embedded system and 44 pins IDE to SD Adapter can be easily installed on all Vortex86DX-63xx CPU boards. You or your customers just do the BIOS setting and use SD-1917 to connect IDE connector of Vortex86DX-63xx directly.

For further inquiries of SD-1917, please contact ICOP sales team or mail to: [info@icop.com.tw](mailto:info@icop.com.tw) for your request.

### <BIOS setting>

- Get into the BIOS setup Utility
- Choose Primary IDE Pin Select: SD card
- Press “F10” to Save configuration changes and exit setup

### SD-1917



**SD-1917:** <http://www.icop.com.tw/pddetail.aspx?id=125&pid=4>

**(Note1: Linux can use with Compact Flash card only.)**

# Chapter 3

## Driver Installation

### LAN

The Vortex86DX processor also integrated 10/100Mbps Ethernet controller that supports both 10/100BASE-T and allows direct connection to your 10/100Mbps Ethernet based Local Area Network for full interaction with local servers, wide area networks such as the Internet.

The controller supports: Half / Full-Duplex Ethernet function to double channel bandwidth, auto media detection.

### Operating system support

The Vortex86DX-6315RD Tiny CPU board supports Embedded software: Free DOS, DOS 6.22, PCDOS 7.1, DR-DOS,x-DOS,OS/2,Windows CE 6.0, Windows 98, Windows XP Professional, Windows Embedded standard (XPE) and Windows 2000 (SP4).

Please get the drivers from the Driver CD which attached with the standard packing of Vortex86DX-6315RD board or please get it from DMP official website:

<http://www.dmp.com.tw/tech/vortex86dx/>

Vortex86DX-6315RD also supports most of the popular Linux distributions, for more detail information, please visit DMP official website: <http://www.dmp.com.tw/tech/vortex86dx/>

# Appendix

## A. TCP/IP library for DOS real mode

DSock is a TCP/IP library for DOS real mode, which is used by RSIP. It provides simple C functions for programmer to write Internet applications. ICOP also provide Internet examples using DSock: BOOTP/DHCP, FTP server, SMTP client/server, HTTP server, TELNET server, Talk client/server, etc.

DSock provides a lot of example source code. Programmer can add Internet functions to their project easily and save development time. With a utility "MakeROM", programmer also can make a ROM image to fit their application, those examples can be seen in the following Application systems: Mity-Mite Serial Server, Web Camera Tiny Server and RSIP Serial Server.

DSock is free for All ICOP products using M6117D/Vortex86/Vortex86SX/Vortex86DX CPU and ICOP also provide the business version of DSock for those customers who are using other x86 CPUs.

If you would like to use DSock or business version of DSock, Please mail to [info@icop.com.tw](mailto:info@icop.com.tw) or contact your regional sales.

Please download the trial DSock software and Utilities from our website:

<http://www.dmp.com.tw/tech/dmp-lib/dsock/>

## B. BIOS Default setting

If the system cannot be booted after BIOS changes are made, Please follow below procedures in order to restore the CMOS as default setting.

- Press “End” Key, when the power on



- Press <Del> to enter the AMI BIOS setup
- Press “F9” to Load Optimized Defaults
- Press “F10” to Save configuration changes and exit setup

# Warranty

This product is warranted to be in good working order for a period of one year from the date of purchase. Should this product fail to be in good working order at any time during this period, we will, at our option, replace or repair it at no additional charge except as set forth in the following terms. This warranty does not apply to products damaged by misuse, modifications, accident or disaster. Vendor assumes no liability for any damages, lost profits, lost savings or any other incidental or consequential damage resulting from the use, misuse of, originality to use this product. Vendor will not be liable for any claim made by any other related party. Return authorization must be obtained from the vendor before returned merchandise will be accepted. Authorization can be obtained by calling or faxing the vendor and requesting a Return Merchandise Authorization (RMA) number. Returned goods should always be accompanied by a clear problem description.