



ADLINK
TECHNOLOGY INC.

PCI-6308
Isolated Analog Output Board
User's Manual

Manual Rev. 2.01
Revision Date: December 21, 2006
Part No: 50-11101-102



Recycled Paper

Advance Technologies; Automate the World.



Copyright 2005 ADLINK TECHNOLOGY INC.

All Rights Reserved.

The information in this document is subject to change without prior notice in order to improve reliability, design, and function and does not represent a commitment on the part of the manufacturer.

In no event will the manufacturer be liable for direct, indirect, special, incidental, or consequential damages arising out of the use or inability to use the product or documentation, even if advised of the possibility of such damages.

This document contains proprietary information protected by copyright. All rights are reserved. No part of this manual may be reproduced by any mechanical, electronic, or other means in any form without prior written permission of the manufacturer.

Trademarks

Product names mentioned herein are used for identification purposes only and may be trademarks and/or registered trademarks of their respective companies.

Getting Service from ADLINK

Customer Satisfaction is top priority for ADLINK Technology Inc. Please contact us should you require any service or assistance.

ADLINK TECHNOLOGY INC.

Web Site: <http://www.adlinktech.com>
 Sales & Service: Service@adlinktech.com
 TEL: +886-2-82265877
 FAX: +886-2-82265717
 Address: 9F, No. 166, Jian Yi Road, Chungho City,
 Taipei, 235 Taiwan

Please email or FAX this completed service form for prompt and satisfactory service.

Company Information	
Company/Organization	
Contact Person	
E-mail Address	
Address	
Country	
TEL	FAX:
Web Site	
Product Information	
Product Model	
Environment	OS: M/B: CPU: Chipset: Bios:

Please give a detailed description of the problem(s):

Table of Contents

1	Introduction	1
1.1	Features.....	2
1.2	Applications	2
1.3	Specifications.....	3
	Voltage Output	3
	Current Output	4
	Digital Input	4
	Digital Output	4
	Power Supply source	5
	General Specifications	5
1.4	Supporting Software	6
	Programming Library	6
	DAQ-LVIEW: LabVIEW® Driver	7
	PCIS-VEE: HP-VEE Driver	7
	PCIS-OCX: ActiveX Controls	7
	DASYLab™ PRO	7
	PCIS-DDE: DDE Server and InTouch™	7
	PCIS-ISG: ISaGRAFTM driver	8
	PCIS-ICL: InControl™ Driver	8
	PCIS-OPC: OPC Server	8
2	Installation	9
2.1	Contents of Package	9
2.2	Unpacking.....	10
2.3	PCI-6308V Layout	11
2.4	PCI-6308V 0A5	12
2.5	Hardware Installation Outline.....	13
	Hardware configuration	13
	PCI slot selection	13
	Installation Procedures	13
2.6	Device Installation for Windows Systems	14
2.7	Connector Pin Assignment	15
2.8	Jumper Settings.....	17
2.9	Termination Board Connection	18
3	Registers.....	19
3.1	PCI PnP Registers.....	19
3.2	I/O Address Map.....	20

3.3	DA Output Register.....	20
3.4	Digital Output Register.....	21
3.5	Digital Input Ports.....	21
4	Operation Theory	23
4.1	Voltage Output.....	23
	Voltage Output Range Selection	23
	DA data format	23
4.2	Analog Output Status Register	25
4.3	Current Output and Range Control.....	25
4.4	Isolated Digital Output.....	26
4.5	Isolated Digital Input	27
5	C/C++ Library	29
5.1	Libraries Installation	29
5.2	Programming Guide.....	29
	Naming Convention	29
	Data Types	30
5.3	_6308_Initial	31
	@ Description	31
	@ Syntax	31
	@ Arguments	31
	@ Return Code	31
5.4	_6308_Software_Reset	32
	@ Description	32
	@ Syntax	32
	@ Arguments	32
	@ Return Code	32
5.5	_6308_DA.....	33
	@ Description	33
	@ Syntax	33
	@ Arguments	33
	@ Return Code	33
5.6	_6308_DA_0_3.....	34
	@Description	34
	@Syntax	34
	@Arguments	34
	@Return Code	34
5.7	_6308_DA_4_7.....	35
	@Description	35

	@Syntax	35
	@Return Code	35
5.8	_6308_Get_DA_Status	36
	@ Description	36
	@ Syntax	36
	@ Arguments	36
	@ Return Code	36
5.9	_6308_DI	37
	@ Description	37
	@ Syntax	37
	@ Arguments	37
	@ Return Code	37
5.10	_6308_DO	38
	@ Description	38
	@ Syntax	38
	@ Arguments	38
	@ Return Code	38
5.11	_6308_I2V_Control	39
	@ Description	39
	@ Syntax	39
	@ Arguments	39
	@ Return Code	39

List of Tables

Table 2-1: CN1 Pin Assignment Legend	16
Table 2-2: Channel Jumper Settings	17
Table 2-3: Output Range Jumper Settings	18
Table 3-1: I/O Address Map	20
Table 3-2: DA Output Register	20
Table 3-3: Digital Output Register	21
Table 3-4: Digital Input Ports	21
Table 4-1: DA Voltage Output Format	24
Table 5-1: Data Types	30

List of Figures

Figure 2-1: PCI-6308V Layout	11
Figure 2-2: PCI-6308V 0A5 Version	12
Figure 2-3: CN1 Pin Assignment	15
Figure 4-1: Current Output Circuit.....	25
Figure 4-2: Isolated Digital Output	26
Figure 4-3: Isolated Digital Input	27

1 Introduction

The PCI-6308 series of isolated analog output cards includes the following three cards:

- ▶ PCI-6308V: Isolated 8-CH voltage output card
- ▶ PCI-6308A: Isolated 8-CH voltage and current output card
- ▶ PCI-6304V: Isolated 4-CH voltage output card

The PCI-6308V is a high-performance, 12-bit analog output board with PCI interface that provides 8 identical voltage output channels, with each channel capable of: (1) bipolar $\pm 10\text{V}$ voltage outputs; (2) unipolar 0 - +10V voltage output; and (3) unipolar 0 to user defined voltage output.

The PCI-6308V adopts the AD7564BRSZ, a state-of-the-art and fully monotonic digital to analog converter. The AD7564 is a current output DA converter which requires external reference voltage provided by TI REF102. The REF102 is a precision 10V voltage reference. The drift is laser-trimmed to 2.5ppm/ $^{\circ}\text{C}$ max over the industrial temperature range.

The PCI-6308A is the combination of the PCI-6308V and a 8-CH current output daughter board EXP-8A. The EXP-8A daughter board includes 8 precision voltage-to-current converters/transmitters, which convert voltage output of PCI-6308V to a current source output. The EXP-8A is piggybacked onto the PCI-6308V. Therefore, the PCI-6308A provides both voltage and current outputs at the same time. That is, the change of current output has the direct proportion comparing to the change of voltage output.

1.1 Features

- ▶ 8-CH 12-bit voltage output
- ▶ Fully isolation protection from PC power to external device
- ▶ 3750Vrms isolation voltage for DA
- ▶ 2500Vrms isolation voltage for DIO
- ▶ Unipolar or bipolar voltage output range
- ▶ Current output available on PCI-6308A,
- ▶ On board DC-to-DC converter provide voltage and current source
- ▶ 4 Isolated digital input channels
- ▶ 4 Isolated digital output channels
- ▶ Supports Universal +3.3V and +5V PCI Bus (Rev. 0A5)
- ▶ Supports +5V PCI Bus (Previous Version)

1.2 Applications

- ▶ Industrial Process Control
- ▶ Pressure / Temperature Transmitter
- ▶ Current Source for Testing Equipment
- ▶ Servo Control

1.3 Specifications

Voltage Output

- ▶ Numbers of channel: 8 channel for PCI-6308V and PCI-6308A
- ▶ Converter: AD7564 or equivalent
- ▶ Conversion type: Monolithic multiplying
- ▶ Resolution: 12-bit no missing code (11-bit guarantee)
- ▶ Voltage output range: (jumper selectable)
 - ▷ Bipolar: $\pm 10V$
 - ▷ Unipolar: 0 - 10V
 - ▷ User defined unipolar: 0 - user defined voltage (inner $\pm 15V$)
- ▶ Voltage output driving capability: $\pm 20mA$ Max.
- ▶ Settling time: $10\mu s$ (-10V to +10V)
- ▶ DA update time: $13.96 \mu s$ for four channels simultaneously (depending on user system)
- ▶ Gain error: $\pm 1LSB$ (typical, without trimming, with internal 10.0V reference voltage)
- ▶ Differential Linearity Error: $\pm 0.2LSB$ Full Scale Range
- ▶ Data Transfer: Programmed I/O
- ▶ Isolation voltage: 3750Vrms (photo isolation PC410)
- ▶ Output initial status: 0V (after RESET or POWER-ON)

Current Output

- ▶ Numbers of channel: 8 channel for PCI-6308A
- ▶ Current output range: 0~20mA, 4~20mA, 5~25mA. (Software programmable)
- ▶ Voltage to current converter: B.B. XTR110 or equivalent
- ▶ Settling time: 17 μ s (0~20mA)
- ▶ Slew rate: 1.3mA / μ s
- ▶ Non-linearity: \pm 0.01 % of Span
- ▶ Span error: 0.3% of initial Span
- ▶ Output resistance: 10 Ohms maximum
- ▶ Output initial status: 0mA (after RESET or POWER-ON)

Digital Input

- ▶ Numbers of digital input channel: 4 isolated input channel
- ▶ Photo isolator: PC3H4 or equivalent
- ▶ Isolation voltage: 2500Vrms
- ▶ Input voltage: up to 34Vdc
 - ▷ Logic "L": 0~3.0V
 - ▷ Logic "H": 3.2~34V
- ▶ Input resistance: 2.4K Ω @ 0.5W

Digital Output

- ▶ Numbers of digital output channel: 4 isolated output channel
- ▶ Photo isolator: PC3H7 or equivalent
- ▶ Isolation voltage: 2500Vrms
- ▶ Output type: Photo-coupler transistors, open collector up to 35Vdc
- ▶ Sink current: 50mA maximum

Power Supply source

- ▶ +15V output (Pin #7 on CN1):
 - ▷ 200mA maximum (for PCI-6308V)
 - ▷ 20mA maximum (for PCI-6308A, when all current output channel is 25mA)
- ▶ -15V output (Pin #25 on CN1):
 - ▷ 200mA maximum (for PCI-6308V)
 - ▷ 20mA maximum (for PCI-6308A, when all current output channel is 25mA)

General Specifications

- ▶ Operating temperature: 0 ~ 55°C
- ▶ Storage temperature: -20 ~ 80°C
- ▶ Humidity: 5 ~95% non-condensing
- ▶ Connector: 37-pin D-sub connector (female)
- ▶ Bus interface: 32-bit slave PCI bus
- ▶ Power consumption:
 - ▷ PCI-6308V: +5VDC @ 220mA typical
+12VDC @ 175mA typical
 - ▷ PCI-6308A: +5VDC @ 220mA typical
+12VDC @ 250mA typical
Or +12VDC @ 530mA (when all current output channels are 25mA)
- ▶ PCB Dimension: Half-sized 172 mm x 105 mm

1.4 Supporting Software

ADLINK provides versatile software drivers and packages for different approaches to building up a system. We not only provide programming libraries such as DLL for many Windows systems, but also provide drivers for many software package such as LabVIEW®, HP VEE™, DASYS Lab™, InTouch™, InControl™, ISaGRAF™, and so on.

All software options are included in the ADLINK CD. Non-free software drivers are protected with licensing codes. Without the software code, you can still install and run the demo version for two hours for trial/demonstration purposes. Please contact ADLINK dealers to purchase the formal license.

Programming Library

For customers who are writing their own programs, we provide function libraries for many different operating systems, including:

- ▶ **DOS Library:** Borland C/C++ and Microsoft C++, the functions descriptions are included in this user's guide.
- ▶ **Windows 95 DLL:** For VB, VC++, Delphi, BC5, the functions descriptions are included in this user's guide.
- ▶ **PCIS-DASK:** Include device drivers and DLL for Windows 98/NT/2000/XP. DLL is binary compatible across Windows 98, Windows NT and Windows 2000. That means all applications developed with PCIS-DASK are compatible across Windows 98/NT/2000/XP. The developing environment can be VB, VC++, Delphi, BC5, or any Windows programming language that allows calls to a DLL. The user's guide and function reference manual of PCIS-DASK are in the CD. Please refer the PDF manual files under \\Manual\NuDAQ PCI_cPCI
- ▶ **PCIS-DASK/X:** Includes device drivers and shared library for Linux. The developing environment can be Gnu C/C++ or any programming language that allows linking to a shared library. The user's guide and function reference manual of PCIS-DASK/X are in the CD (\\Manual\NuDAQ PCI_cPCI).

The above software drivers are shipped with the board. Please refer to the “Software Installation Guide” for installation procedures.

DAQ-LVIEW: LabVIEW® Driver

DAQ-LVIEW contains the VIs, which are used to interface with NI's LabVIEW® software package. The DAQ-LVIEW supports Windows 98/NT/2000/XP. The LabVIEW® drivers is shipped free with the board. You can install and use them without any license. For more information about PCIS-LVIEW, please refer to the user's guide in the CD. (\\Manual\Software Package\DAQ-LVIEW PnP)

PCIS-VEE: HP-VEE Driver

The PCIS-VEE includes user objects, which are used to interface with the HP VEE software package. PCIS-VEE supports Windows 98/NT/2000/XP. The HP-VEE drivers are shipped free with the board. For more information about PCIS-VEE, please refer to the user's guide in the CD. (\\Manual\Software Package\PCIS-VEE)

PCIS-OCX: ActiveX Controls

We suggest customers who are familiar with ActiveX controls and VB/VC++ programming use the PCIS-OCX ActiveX Control component library for developing applications. The DAQBench™ is designed for Windows 98/NT/2000/XP. For more information about PCIS-OCX, please refer to the user's guide in the CD. (\\Manual\Software Package\PCIS-OCX).

DASYLab™ PRO

DASYLab is an easy-to-use software package, which provides easy-setup instrument functions such as FFT analysis. Please contact ADLINK to obtain DASYLab PRO, which includes DASYLab and ADLINK hardware drivers.

PCIS-DDE: DDE Server and InTouch™

DDE stands for Dynamic Data Exchange. The PCIS-DDE includes the PCI cards' DDE server. The PCIS-DDE server is included in

the ADLINK CD. It needs a license. The DDE server can be used in conjunction with any DDE client under Windows NT.

PCIS-ISG: ISaGRAF™ driver

The ISaGRAF WorkBench is an IEC1131-3 SoftPLC control program development environment. The PCIS-ISG includes ADLINK product drivers for ISaGRAF under Windows NT environment. The PCIS-ISG is included in the ADLINK CD. A license is needed to use the drivers.

PCIS-ICL: InControl™ Driver

PCIS-ICL is the InControl driver, which supports Windows 98/NT/2000/XP. The PCIS-ICL is included in the ADLINK CD. A license is needed to use the drivers.

PCIS-OPC: OPC Server

PCIS-OPC is an OPC Server, which can link with OPC clients. There are several software packages on the market, which can provide the OPC clients. The PCIS-OPC supports Windows NT and requires a license to operate.

2 Installation

This chapter outlines the contents of package, describes unpacking information, and describes how to install PCI-6308 hardware and software.

2.1 Contents of Package

The package includes the following items:

- ▶ PCI-6308V (or PCI-6308A) Board
- ▶ ADLINK All-in-one Compact Disc
- ▶ This User's Manual
- ▶ Software Installation Guide

If any of these items are missing or damaged, contact your ADLINK dealer. Save the shipping materials and carton in to ship or store the product in the future.

2.2 Unpacking

The PCI-6308 contains electro-static sensitive components that can be easily be damaged by static electricity.

Therefore, the module should be handled on a grounded anti-static mat. The operator should be wearing an anti-static wristband, grounded at the same point as the anti-static mat.

Inspect the module for obvious damage. Shipping and handling may cause damage to the module. Be sure there are no shipping and handling damage on the module before continuing.

You are now ready to install your PCI-6308.

Note: DO NOT APPLY POWER TO THE CARD IF IT HAS BEEN DAMAGED.

2.3 PCI-6308V Layout

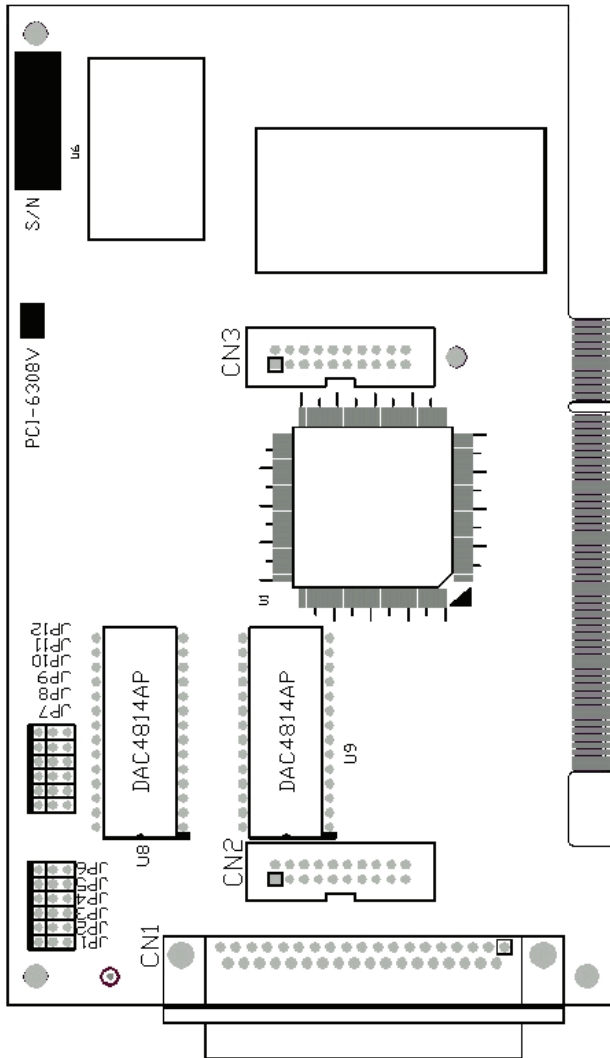

Figure 2-1: PCI-6308V Layout

2.4 PCI-6308V 0A5

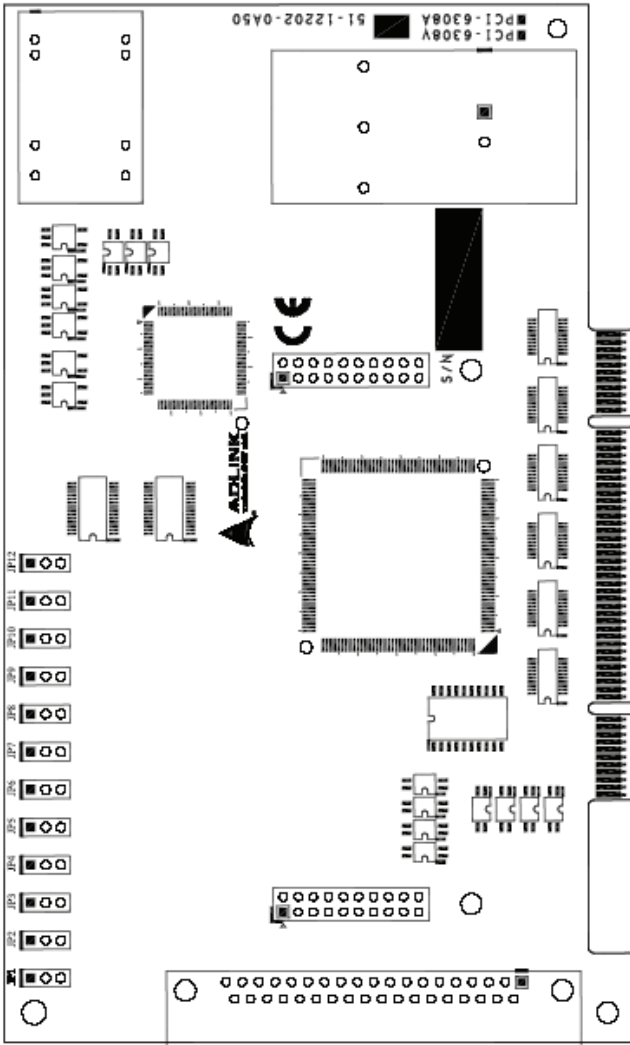

Figure 2-2: PCI-6308V 0A5 Version

2.5 Hardware Installation Outline

Hardware configuration

The PCI cards (or CompactPCI cards) are equipped with plug and play PCI controllers, it can request base addresses and interrupts according to the PCI standard. The system BIOS will assign the system resources based on the PCI cards' configuration registers and system parameters (which are set by the system BIOS). Interrupt assignment and memory usage (I/O port locations) can only be assigned by the system BIOS. These system resource assignments are done on a board-by-board basis. It is not suggested to assign the system resource by any other methods.

PCI slot selection

The PCI card can be inserted into any PCI slot without any configuration of the system resources. The CompactPCI card can also be inserted into any CompactPCI I/O slot.

Installation Procedures

1. Turn off your computer
2. Turn off all accessories (printer, modem, monitor, etc.) connected to your computer.
3. Remove the cover from your computer.
4. Setup jumpers on the PCI or CompactPCI card.
5. Select a 32-bit PCI slot. PCI slot are shorter than ISA or EISA slots, and are usually white or ivory.
6. Before handling the PCI cards, discharge any static buildup on your body by touching the metal case of the computer. Hold the edge and do not touch the components.
7. Position the board into the PCI slot you selected.
8. Secure the card in place at the rear panel of the system.

2.6 Device Installation for Windows Systems

Once Windows 98/2000/XP has started, the Plug and Play functions of the Windows system will find and locate the new NuDAQ/NuIPC card. If this is the first time a NuDAQ/NuIPC card is installed in your Windows system, you will be prompted to input the device information source. Please refer to the “Software Installation Guide” for installation procedures of the device drivers.

2.7 Connector Pin Assignment

The pin assignment of PCI-6308V/6308A/6304V are shown in the figure below:

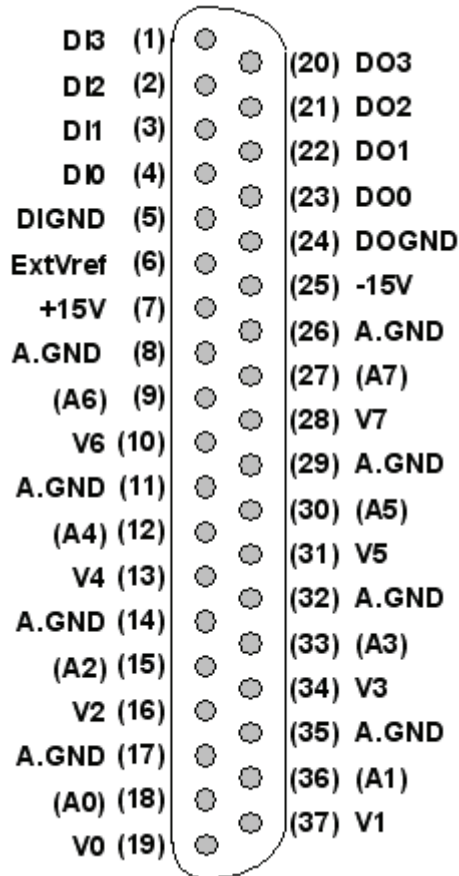

Figure 2-3: CN1 Pin Assignment

Legend	
Vn	The voltage output of channel n. For PCI-6308V/6308A, n=0~7.
An	the current output of channel n. An is used by the PCI-6308A only, n=0~7.
ExtVref	External reference voltage for voltage output.
AGND	Ground of analog output channels and +/-15V.
-15V	-15V voltage output.
+15V	+15V voltage output.
Dlx	Digital input channel x.
DOx	Digital Output channel x.
DIGND	Isolated ground of digital input.
DOGND	Isolated ground of digital output.

Table 2-1: CN1 Pin Assignment Legend

2.8 Jumper Settings

The PCI-6308's voltage output channels can be configured with different voltage range. Each output channel and its corresponding jumpers are listed below.

Channel NO.	Corresponding Jumper For output mode (Unipolar/Bipolar)		Corresponding Jumper For reference voltage sources (external/internal)
CH0	JP1	JP9	JP11
CH1	JP2	JP9	JP11
CH2	JP3	JP9	JP11
CH3	JP4	JP9	JP11
CH4	JP5	JP10	JP12
CH5	JP6	JP10	JP12
CH6	JP7	JP10	JP12
CH7	JP8	JP10	JP12

Table 2-2: Channel Jumper Settings

The output range is dependent on the D/A converter's reference voltage source and output mode (Bipolar or Unipolar). JP11 and JP12 are used for setting reference voltage sources from either internal or external. External reference voltage input (ExtVref) is located on connector CN1. JP1~8 and JP9/10 are used to set the output mode to be unipolar or bipolar.

Output Range	Unipolar/Bipolar		external/ internal
	JP1~JP8	JP9~JP10	JP11~JP12
-10V to +10V Bipolar (Default)			
0V to +10V Unipolar			
0V to ExtRef Voltage Unipolar			

Table 2-3: Output Range Jumper Settings

2.9 Termination Board Connection

The PCI-6308 is equipped with a DB-37 connector. The available termination boards include:

- ▶ ACLD-9137: A general purposed 37-pin screw terminal. The ACLD-9137 has a DB-37 male connector, which is used to directly attach to the PCI-6308.
- ▶ ACLD-9188: A general purposed 37-pin screw terminal, which is equipped with a heavy-duty screw terminal
- ▶ DIN-37D: A general purposed 37-pin screw terminal with a DIN-socket, which provides for easily installation. DIN-37D is shipped with a 37-pin cable.

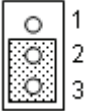
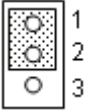
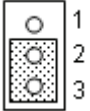
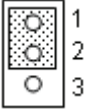
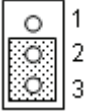
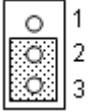
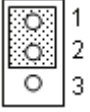
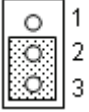
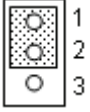
3 Registers

The descriptions of the registers and structure of the PCI-6308 Series are outlined in this chapter. The information in this chapter will assist programmers, who wish to handle the card with low-level programs.

In addition, the low level programming syntax is introduced. This information can help beginners to operate the 743X in the shortest possible time.

3.1 PCI PnP Registers

This PCI card functions as a 32-bit PCI target device to any master on the PCI bus. There are three types of registers: PCI Configuration Registers (PCR), Local Configuration Registers (LCR) and PCI-6308 registers.

The PCR, which is PCI-bus specifications compliant, is initialized and controlled by the plug & play (PnP) PCI BIOS. Users may obtain more information on the PCI BIOS specification to better understand the operation of the PCR. Please contact PCISIG to acquire the specifications of the PCI interface.

The PCI bus controller PCI-9052 is provided by PLX technology Inc. (www.plxtech.com). For more information about the LCR, please visit PLX technology's web site to download relative information. It is not necessary for users to fully understand the details of the LCR if the software library provided is used. The PCI PnP BIOS assigns the base address of the LCR. The assigned address is located at an offset of 14h from the PCR.

The PCI-6308 registers are discussed in the next section. The base address, which is also assigned by the PCI PnP BIOS, is located at an offset of 18h from the PCR. Therefore, users can read the address 18h from the PCR to obtain its base address by using the BIOS function call. Do not attempt to modify the base address and interrupt that have been assigned by the PCI PnP BIOS, it may cause resource conflicts with your system.

3.2 I/O Address Map

Most of the PCI-6308 registers are 16 bits. Users can access these registers using 16-bit I/O instructions. The following table shows the registers map, including descriptions and their offset addresses relative to the base address.

I/O Address	Write	Read
Base + 00h	DA Channel #3 value	DA Sent Status
Base + 02h	DA Channel #2 value	--
Base + 04h	DA Channel #1 value	--
Base + 06h	DA Channel #0 value	--
Base + 08h	DA Channel #7 value	--
Base + 0Ah	DA Channel #6 value	--
Base + 0Ch	DA Channel #5 value	--
Base + 0Eh	DA Channel #4 value	--
Base + 10h ~3Eh	Reserved	
Base + 40h	Digital Input	Digital Output

Table 3-1: I/O Address Map

3.3 DA Output Register

There are 8 analog output channels on the PCI-6308. Every channel is 12-bits.

Address: BASE + 00(hex) ~ BASE+ 0E(hex)

Attribute: write only

Data Format:

Bit	7	6	5	4	3	2	1	0
BASE+0	DA7	DA6	DA5	DA4	DA3	DA2	DA1	DA0
Bit	15	14	13	12	11	10	9	8
BASE+1	--	--	--	--	DA11	DA10	DA9	DA8

Table 3-2: DA Output Register

3.4 Digital Output Register

D0~D3 is the digital output signal written to the output channel.
 D4~D7 don't care.

Address: BASE + 40(hex)

Attribute: write only

Data Format:

Bit	7	6	5	4	3	2	1	0
BASE+20	X	X	X	X	DO3	DO2	DO1	DO0

Table 3-3: Digital Output Register

3.5 Digital Input Ports

D4~D7 is the digital input signal from CN1.

D0~D3 is read back signal from the digital output channel.

Address: BASE + 40(hex)

Attribute: read only

Data Format:

Bit	7	6	5	4	3	2	1	0
BASE+20	DI3	DI2	DI1	DI0	DO3	DO2	DO1	DO0

Table 3-4: Digital Input Ports

4 Operation Theory

In this chapter, the detail operation theory of the PCI-6308V and PCI-6308A is described. Before programming or applying the PCI-6308 card to your application, please go through this chapter to understand the features first.

4.1 Voltage Output

There are 8 voltage output channels for PCI-6308V and 6308A. For voltage output operation, you have to understand:

1. How to set the voltage output range.
2. The DA data format.

Voltage Output Range Selection

The DA converter chip of the PCI-6308 is Analog Device AD7564BRSZ, which has 12-bit resolution. By using OPA2134, user can set the voltage output polarity by JP1~JP8. Please refer to section 2.7 for detail of the jumper settings. The selectable range is +/-10V, 0~+10V and 0V ~ user defined voltage. User-defined voltage is inputted from the DB-37 connector at pin #6.

DA data format

The DA data format is a 12-bit unsigned value for all channels, that is, the value is in binary format. The digital value range from 0(0X000) to +4095(0xFFFF) corresponds to the full span of the output range, which is set by the jumpers. Table 4.1 shows the relationship between the digital value and the analog output voltage.

If the application requires a smaller voltage range, the PCI-6308 can still be applied. For example, if the application voltage range is uni-polar between 0~5V, user need only set jumper to external reference mode, and supply a 5V source to pin 6 of CN1.

For +/-10V mode:

Digital Value	HEX value	Output Voltage
4095	0xFFF	+9.99969V
2048	0x800	0.00000V
0	0x000	-10.00000V

For 0~+10V mode:

Digital Value	HEX value	Output Voltage
4095	0xFFF	+9.99969V
2048	0x800	5.00000V
0	0x000	0.00000V

For 0V~V_{user} mode:

Digital Value	HEX value	Output Voltage
4095	0xFFF	+V _{user}
2048	0x800	+V _{user} /2
0	0x000	0.00000V

Table 4-1: DA Voltage Output Format

The above table shows the address of every analog output ports relative to the base address. Note that the base address is assigned by the PCI BIOS. The current output control of the PCI-6308A is described in Section 4.3.

4.2 Analog Output Status Register

The DAC uses a series bus architecture hence there is a delay in the output of the digital value. The data transfer time for every DA data write takes $13\mu\text{s}$, therefore the software driver must wait for $13\mu\text{s}$ before sending another set of data to any analog output port. While the DA value is sending, the Data_Send bit is 'H'. The software driver should check this bit before writing any data to the output port. This register is read only.

Base	D16~D1	D0
0x00	X	Data_Send

4.3 Current Output and Range Control

A precision voltage-to-current converter XTR110 implements the current output. The current output channel n (A_n) is control by the voltage of channel n (V_n). A block diagram of the current output channels is shown in the figure below:

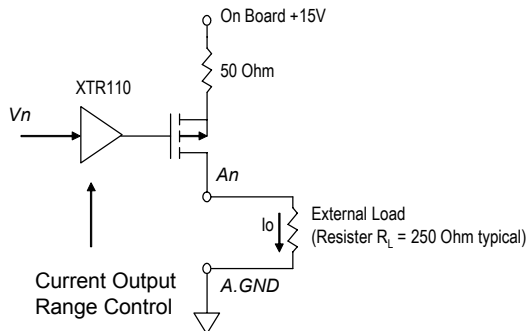

Figure 4-1: Current Output Circuit

The PCI-6308A provides an on board +15V power supply. Each current output channel is a current source, which is controlled by the voltage of the corresponding voltage output channel. For

example, voltage output channel 3 control the current source of channel 3.

The output current range is programmable. The current range control register controls all 8 current channels on the PCI-6308A. There are three kinds of output current ranges. Refer to the following table and Section 5.2.9 for programming the current range using the `_6308_I2V_Control` function.

Mode	Input Voltage Range	Output Current Range
0	0~10V	0~20 mA
1	0~10V	5~25 mA
2	--	--
3	0~10V	4~20 mA

4.4 Isolated Digital Output

The isolated digital output is an open collector transistor output. The isolation voltage between the isolated output and the host power signals is 2500 Vrms

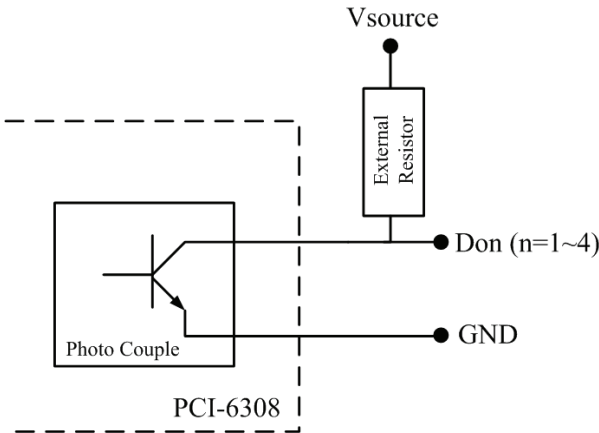

Figure 4-2: Isolated Digital Output

Note: Because the isolation DO is using open collector form, user must add a series resistor on each DO channel to make the DO works correctly.

Note: The V_{source} can accept voltages of up to 24V.

4.5 Isolated Digital Input

The isolated digital input circuits have the following characteristics. The input is equipped with a current-limit resistor. The input voltage can be up to 35V. The isolation voltage between the isolated input and the host power signals is 2500 Vrms.

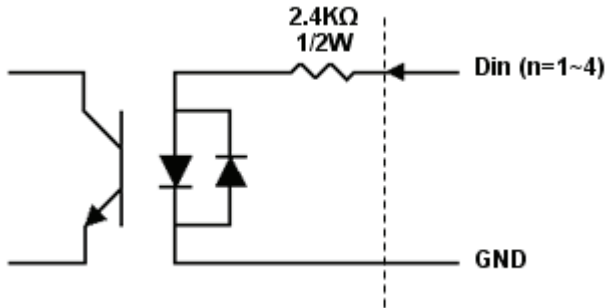

Figure 4-3: Isolated Digital Input

5 C/C++ Library

This chapter describes the software library for operating this card. Only the functions in the DOS library and Windows 95 DLL are described. Please refer to the PCIS-DASK function reference manual, which is included in the ADLINK CD, for descriptions of Windows 98/NT/2000 DLL functions.

Function prototypes and useful constants are defined in the header files of the LIB directory (DOS) and INCLUDE directory (Windows 95). For Windows 95 DLL, the developing environment can be Visual Basic 4.0 or above, Visual C/C++ 4.0 or above, Borland C++ 5.0 or above, Borland Delphi 2.x (32-bit) or above, or any Windows programming language that allows calls to a DLL. The directory provides C/C++, VB, and Delphi INCLUDE files.

5.1 Libraries Installation

Please refer to the “**Software Installation Guide**” for detail information about how to install the software libraries for DOS, Windows 95 DLL, or PCIS-DASK for Windows 98/NT/2000.

The device drivers and DLL functions for Windows 98/NT/2000 are included with the PCIS-DASK. Please refer to the PCIS-DASK user’s guide and function reference, which is included in the ADLINK CD, for detailed programming information.

5.2 Programming Guide

Naming Convention

There are 7 function calls provided by the C Language Library. All the functions of the PCI-6308 are covered in this library.

The functions of the PCI-6308 software driver use full-names to represent the functions’ real meaning. The naming convention rules are:

In DOS Environment:

- ▶ `_{hardware_model}_{action_name}`. e.g. `_6308_Initial()`.

All functions in the PCI-6308 driver start with 6308 as {hardware_model} and can be used by both the PCI-6308V and PCI-6308A.

In order to distinguish the difference between DOS library and Windows 95 library, a capital "W" is place on the beginning of each function name of the Windows 95 DLL driver. e.g. **W_6308_Initial()**.

Data Types

We have defined some data type in the Pci_6308.h (DOS) and Acl_pci.h (Windows 95) header files. These data types are used by the PCI-6308/6216 library and suggest you use these data types in your application programs. The following table shows the data type names and their range.

Type Name	Description	Range
U8	8-bit ASCII character	0 to 255
I16	16-bit signed integer	-32768 to 32767
U16	16-bit unsigned integer	0 to 65535
I32	32-bit signed integer	-2147483648 to 2147483647
U32	32-bit single-precision floating-point	0 to 4294967295
F32	32-bit single-precision floating-point	-3.402823E38 to 3.402823E38
F64	64-bit double-precision floating-point	-1.797683134862315E308 to 1.797683134862315E309
Boolean	Boolean logic value	TRUE, FALSE

Table 5-1: Data Types

5.3 _6308_Initial

@ Description

This function is used to initialize the PCI 6308. Every PCI_6308 has to be initialized by this function before calling other functions.

@ Syntax

C/C++ (DOS)

```
U16 _6308_Initial (U16 *existCards, PCI_INFO
                  *pciInfo)
```

C/C++ (Windows 95)

```
U16 W_6308_Initial (U16 *existCards, PCI_INFO
                   *pciInfo)
```

Visual Basic (Windows 95)

```
W_6308_Initial (existCards As Integer, pciInfo As
                PCI_INFO) As Integer
```

@ Arguments

existCards: number of existing PCI-6308 cards

info: relative information of the PCI-6308 cards

@ Return Code

ERR_NoError

ERR_BoardNoInit

ERR_PCIBiosNotExist

5.4 _6308_Software_Reset

@ Description

This function is used to reset the I/O port configuration. Note that this function cannot re-start the PCI bus and all the hardware setting won't be change either.

@ Syntax

C/C++ (DOS)

```
void _6308_Software_Reset (U16 cardNo)
```

C/C++ (Windows 95)

```
void W_6308_Software_Reset (U16 cardNo)
```

Visual Basic (Windows 95)

```
W_6308_Software_Reset (ByVal cardNo As Integer)
```

@ Arguments

cardNo:the card number of PCI-6308 card

@ Return Code

ERR_NoError

5.5 _6308_DA

@ Description

This function is used to write data to the D/A converters. There are 8 Digital-to-Analog conversion channels on the PCI-6308. The resolution of each channel is 12 bits unsign; i.e. the digital value range from 0 (0x000) to +4095 (0xFFFF). Please refer to section 4.1 for details of the DA data format.

@ Syntax

C/C++ (DOS)

```
U16 _6308_DA (U16 cardNo, U16 chn, I16 DADData)
```

C/C++ (Windows 95)

```
U16 W_6308_DA (U16 cardNo, U16 chn, I16 DADData)
```

Visual Basic (Windows 95)

```
W_6308_DA (ByVal cardNo As Integer, ByVal chn As  
Integer, ByVal DADData As Integer) As Integer
```

@ Arguments

cardNo: The card number of PCI-6308 card
Chn: D/A channel number
DADData: D/A data value

@ Return Code

```
ERR_NoError
```

5.6 _6308_DA_0_3

@Description

This function is used to simultaneously write data to the D/A converters of channel 0 to channel 3. The resolution of each channel is 12 bits unsign; i.e. the digital value range from 0 to 4095. Please refer to section 4.1 for details of the DA data format.

@Syntax

C/C++ (DOS)

```
U16 _6308_DA_0_3(U16 cardNo, I16 DA0_Data, I16
DA1_Data, I16 DA2_Data, I16 DA3_Data)
```

C/C++ (Windows 95)

```
U16 W_6308_DA_0_3(U16 cardNo, I16 DA0_Data, I16
DA1_Data, I16 DA2_Data, I16 DA3_Data)
```

Visual Basic (Windows 95)

```
W_6308_DA_0_3(ByVal cardNo As Integer, ByVal
DA0_Data As Integer, ByVal DA0_Data As
Integer, ByVal DA2_Data As Integer, ByVal
DA3_Data As Integer)
```

@Arguments

cardNo: The card number of PCI-6308 card
DA0_Data: Channel 0 D/A data value
DA1_Data: Channel 1 D/A data value
DA2_Data: Channel 2 D/A data value
DA3_Data: Channel 3 D/A data value

@Return Code

ERR_NoError

5.7 _6308_DA_4_7

@Description

This function is used to simultaneously write data to the D/A converters of channel 4 to channel 7. The resolution of each channel is 12 bits unisgn; i.e. the digital value range from 0 to 4095. Please refer to section 4.1 for details of the DA data format.

@Syntax

C/C++ (DOS)

```
U16 _6308_DA_4_7(U16 cardNo, I16 DA4_Data, I16
DA5_Data, I16 DA6_Data, I16 DA7_Data)
```

C/C++ (Windows 95)

```
U16 W_6308_DA_4_7(U16 cardNo, I16 DA4_Data, I16
DA5_Data, I16 DA6_Data, I16 DA7_Data)
```

Visual Basic (Windows 95)

```
W_6308_DA_4_7(ByVal cardNo As Integer, ByVal
DA4_Data As Integer, ByVal DA5_Data As
Integer, ByVal DA6_Data As Integer, ByVal
DA7_Data As Integer)
```

@Arguments

cardNo: The card number of PCI-6308 card
DA4_Data: Channel 4 D/A data value
DA5_Data: Channel 5 D/A data value
DA6_Data: Channel 6 D/A data value
DA7_Data: Channel 7 D/A data value

@Return Code

ERR_NoError

5.8 _6308_Get_DA_Status

@ Description

This function is used to check the DA data sending status. Because the data transfer time for every DA data takes 16.0 μ s, the software driver must wait for 16.0 μ s before sending another data to any analog output port. This function should be called before writing any data to the output port. While the DA value is sending, the returned value is "1", otherwise the returned value is "0".

@ Syntax

C/C++ (DOS)

```
U16 W_6308_Get_DA_Status (U16 cardNo)
```

C/C++ (Windows 95)

```
U16 W_6308_Get_DA_Status (U16 cardNo)
```

Visual Basic (Windows 95)

```
W_6308_Get_DA_Status (ByVal cardNo As Integer) As  
Integer
```

@ Arguments

cardNo: The card number of PCI-6308 cards

@ Return Code

0 (low): no DA value is sending
1 (high): the DA value is sending

5.9 _6308_DI

@ Description

This function is used to read data from the digital input ports. There are 4 digital input channels on the PCI-6308. The retrieved value is stored in DIData.

@ Syntax

C/C++ (DOS)

```
U16 _6308_DI (U16 cardNo, U16 *DIData)
```

C/C++ (Windows 95)

```
U16 W_6308_DI (U16 cardNo, U16 *DIData)
```

Visual Basic (Windows 95)

```
W_6308_DI (ByVal cardNo As Integer, DIData As  
Integer) As Integer
```

@ Arguments

cardNo:the card number of PCI-6308 cards

DIData:the value read from digital input port

@ Return Code

```
ERR_NoError
```

5.10 _6308_DO

@ Description

This function is used to write data to the digital output ports. There are 4 digital output channels on the PCI-6308, i.e. the output value ranges from 0 to 15.

@ Syntax

C/C++ (DOS)

```
U16 _6308_DO (U16 cardNo, U16 DOData)
```

C/C++ (Windows 95)

```
U16 W_6308_DO (U16 cardNo, U16 DOData)
```

Visual Basic (Windows 95)

```
W_6308_DO (ByVal cardNo As Integer, ByVal DOData  
As Integer) As Integer
```

@ Arguments

cardNo:the card number of PCI-6308 cards

DOData:the value written to digital output port

@ Return Code

```
ERR_NoError
```

5.11 _6308_I2V_Control

@ Description

This function is used to set the PCI-6308As' voltage-to-current mode control. There are three range modes for the PCI-6308A. Please refer to section 3.3 for details of the voltage to current conversion. The three voltage-to-current modes are:

Mode	Input Voltage Range	Output Current Range
I_0to20mA	0~10V	0~20 mA
I_4to20mA	0~10V	4~20 mA
I_5to25mA	0~10V	5~25 mA

@ Syntax

C/C++ (DOS)

```
U16 _6308_I2V_Control (U16 cardNo, U16 ctrl)
```

C/C++ (Windows 95)

```
U16 W_6308_I2V_Control (U16 cardNo, U16 ctrl)
```

Visual Basic (Windows 95)

```
W_6308_I2V_Control (ByVal cardNo As Integer,  
ByVal ctrl As Integer) As Integer
```

@ Arguments

cardNo: the card number of PCI-6308A cards
ctrl: the voltage-to-current mode, the valid modes are shown in the above table. The constants are defined in Pci_6308.h (DOS) and Acl_pci.h (Windows 95).

@ Return Code

```
ERR_NoError
```

Warranty Policy

Thank you for choosing ADLINK. To understand your rights and enjoy all the after-sales services we offer, please read the following carefully.

1. Before using ADLINK's products please read the user manual and follow the instructions exactly. When sending in damaged products for repair, please attach an RMA application form which can be downloaded from: <http://rma.adlinktech.com/policy/>.
2. All ADLINK products come with a limited two-year warranty, one year for products bought in China:
 - ▶ The warranty period starts on the day the product is shipped from ADLINK's factory.
 - ▶ Peripherals and third-party products not manufactured by ADLINK will be covered by the original manufacturers' warranty.
 - ▶ For products containing storage devices (hard drives, flash cards, etc.), please back up your data before sending them for repair. ADLINK is not responsible for any loss of data.
 - ▶ Please ensure the use of properly licensed software with our systems. ADLINK does not condone the use of pirated software and will not service systems using such software. ADLINK will not be held legally responsible for products shipped with unlicensed software installed by the user.
 - ▶ For general repairs, please do not include peripheral accessories. If peripherals need to be included, be certain to specify which items you sent on the RMA Request & Confirmation Form. ADLINK is not responsible for items not listed on the RMA Request & Confirmation Form.

3. Our repair service is not covered by ADLINK's guarantee in the following situations:
 - ▶ Damage caused by not following instructions in the User's Manual.
 - ▶ Damage caused by carelessness on the user's part during product transportation.
 - ▶ Damage caused by fire, earthquakes, floods, lightning, pollution, other acts of God, and/or incorrect usage of voltage transformers.
 - ▶ Damage caused by unsuitable storage environments (i.e. high temperatures, high humidity, or volatile chemicals).
 - ▶ Damage caused by leakage of battery fluid during or after change of batteries by customer/user.
 - ▶ Damage from improper repair by unauthorized ADLINK technicians.
 - ▶ Products with altered and/or damaged serial numbers are not entitled to our service.
 - ▶ This warranty is not transferable or extendible.
 - ▶ Other categories not protected under our warranty.
4. Customers are responsible for shipping costs to transport damaged products to our company or sales office.
5. To ensure the speed and quality of product repair, please download an RMA application form from our company website: <http://rma.adlinktech.com/policy>. Damaged products with attached RMA forms receive priority.

If you have any further questions, please email our FAE staff: service@adlinktech.com.